

Diagnositics and Therapy of the Heart



Ratko Magjarević

University of Zagreb

Faculty of Electrical Engineering and Computing

Croatia

ratko.magjarevic@fer.hr

The Heart

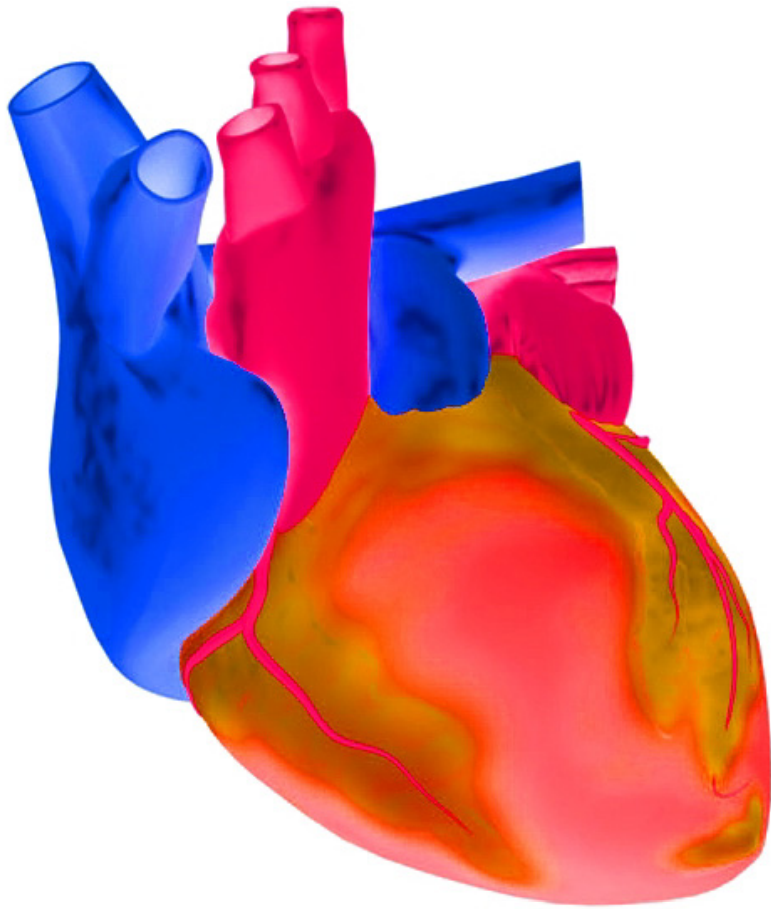

- a hollow, muscular organ
- contracting rhythmically
- keeps up the circulation of the blood
- each day, the average heart beats 100.000 times
- 3.5 billion times in an average lifetime

Anatomy of the Heart

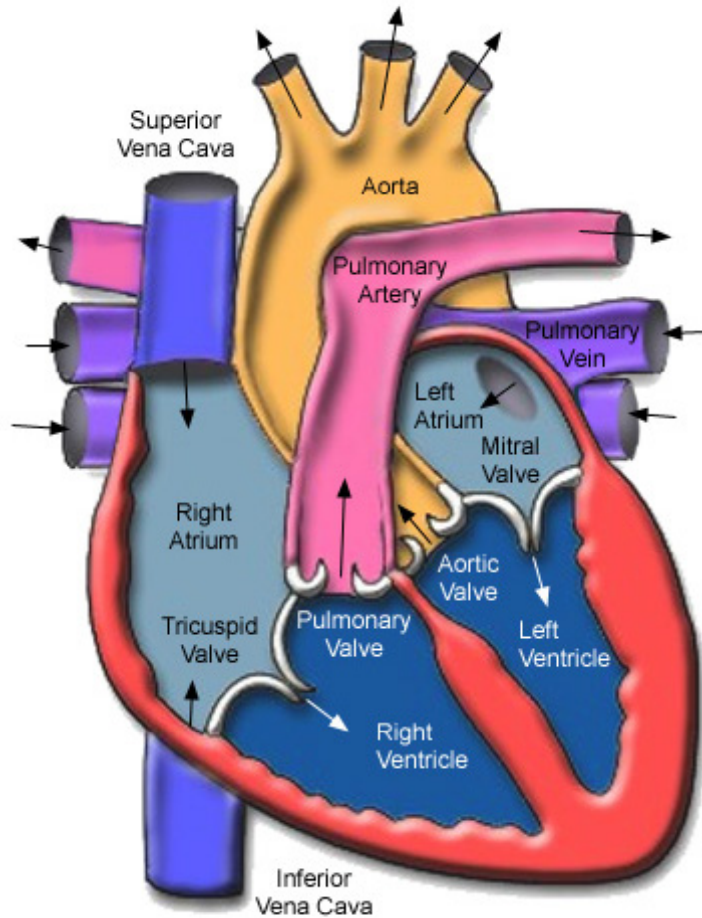

- four-chamber mechanical pump
- upper chambers - left and right atria
- lower chambers - left and right ventricles
- septum (a wall of muscle) separates the left and the right heart

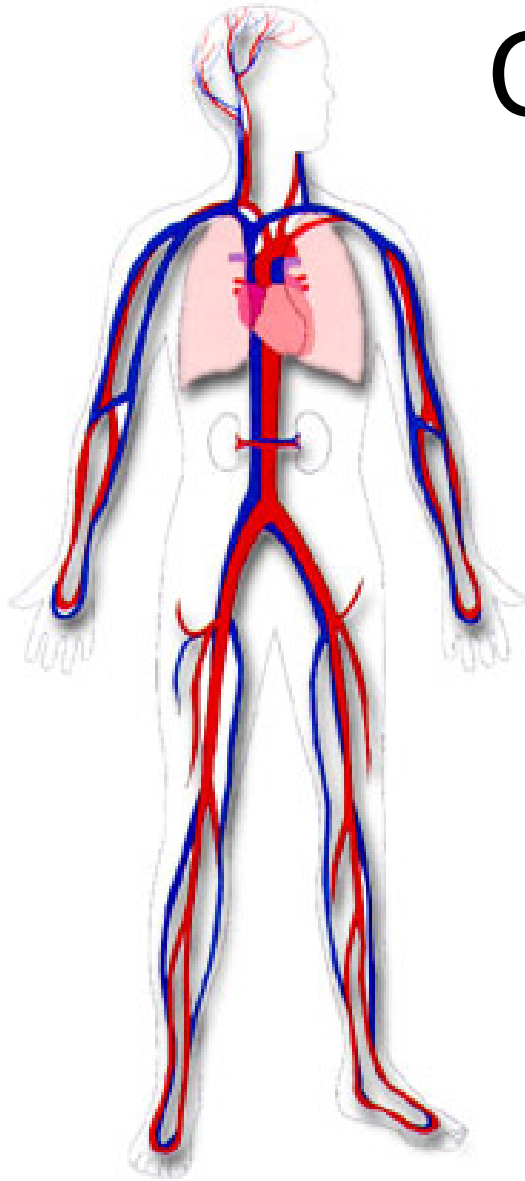

Cardiovascular system

- = heart + blood vessels
- transportation system
- delivery of materials essential for the life of the cells
- carry away waste materials of the metabolism
- synonym: circulatory system

Cardiovascular system

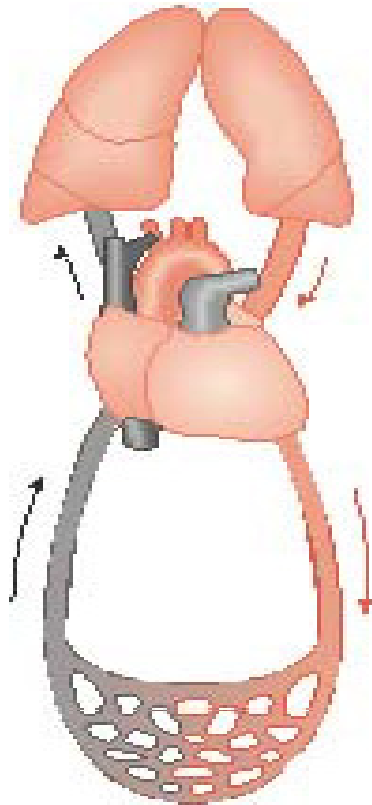

- Pulmonary circulation:
 - right heart sends deoxygenated blood to the lungs through pulmonary arteries
 - oxygenated blood flows into the left heart through pulmonary veins
- Systemic circulation:
 - supplies organs with oxygenated blood
 - enables exchange of nutrients, dissolved gasses and waste products

Simplified Model of the Circulatory System

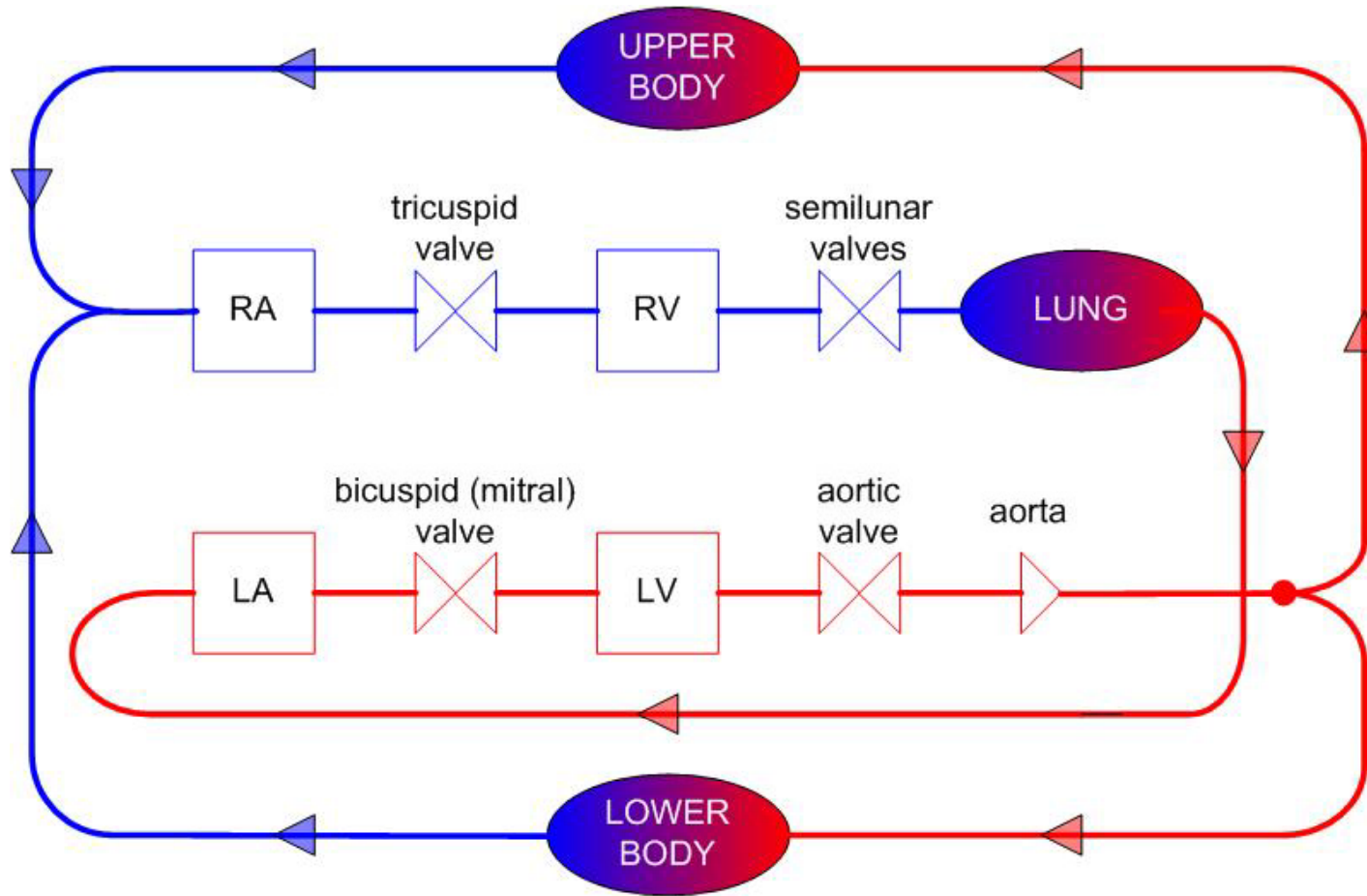

Cardiac Cycle

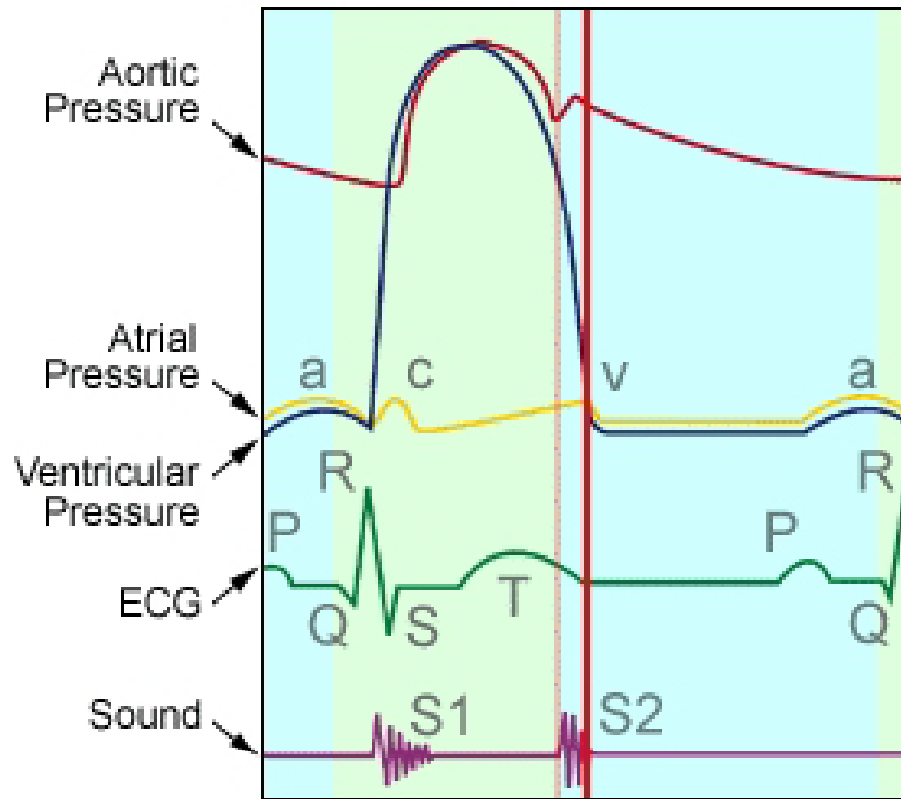

- events during one heart beat
- ventricles fill during diastole
- ventricles contract during systole
- heart rate or pulse – the rate at which the heart beats (75 bpm in adult, resting)

Normal Blood Flow

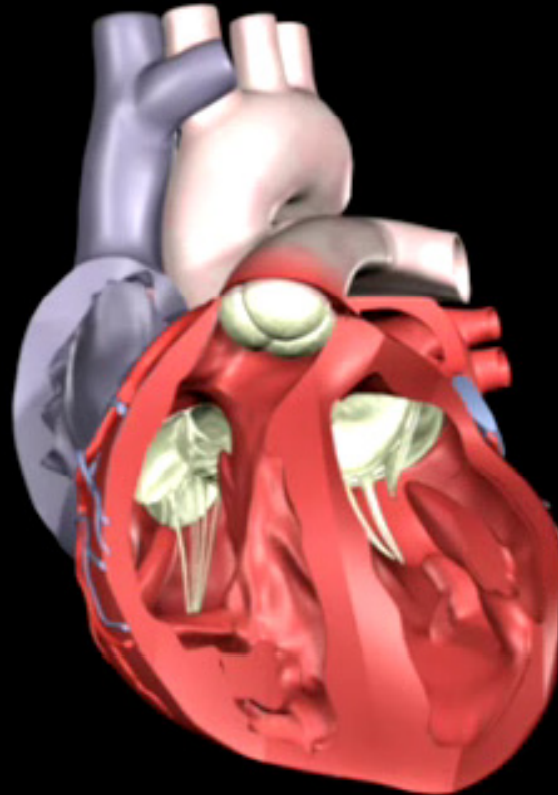

Cardiac Excitation

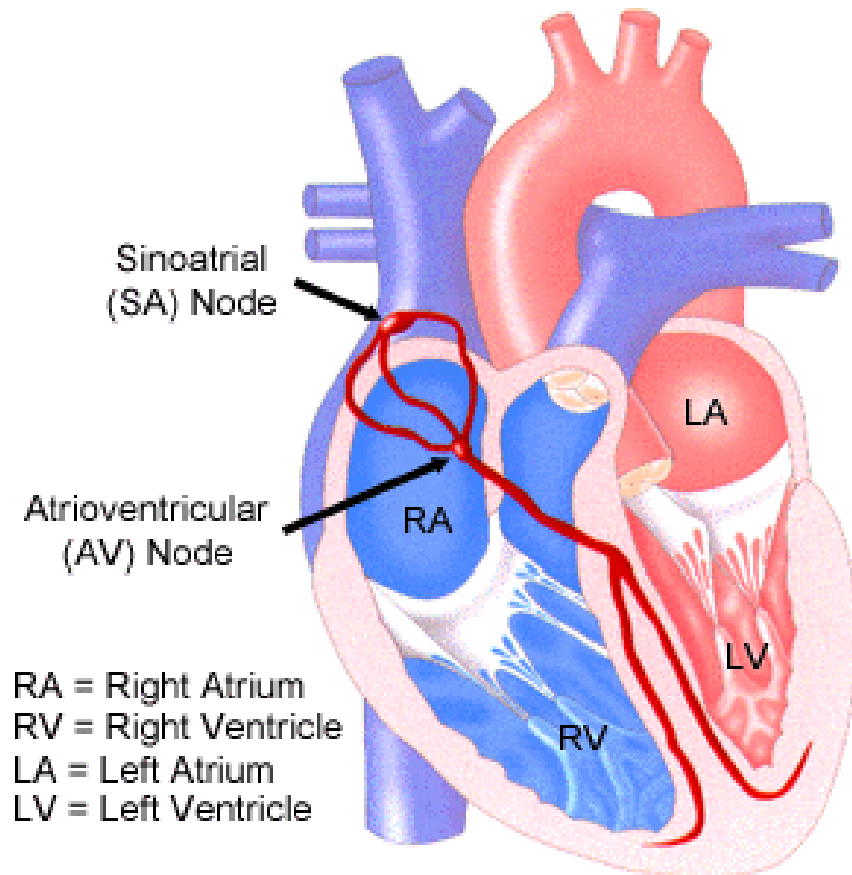

- sinoatrial node – primary pacemaker
- specialized muscle tissue, characteristics of both, muscle and nerves (contracts and generates impulses)
- self-excitabile
- pulses spread at rate of approx. 1 m/s through atria to the atrioventricular node

Cardiac Excitation (cont.)

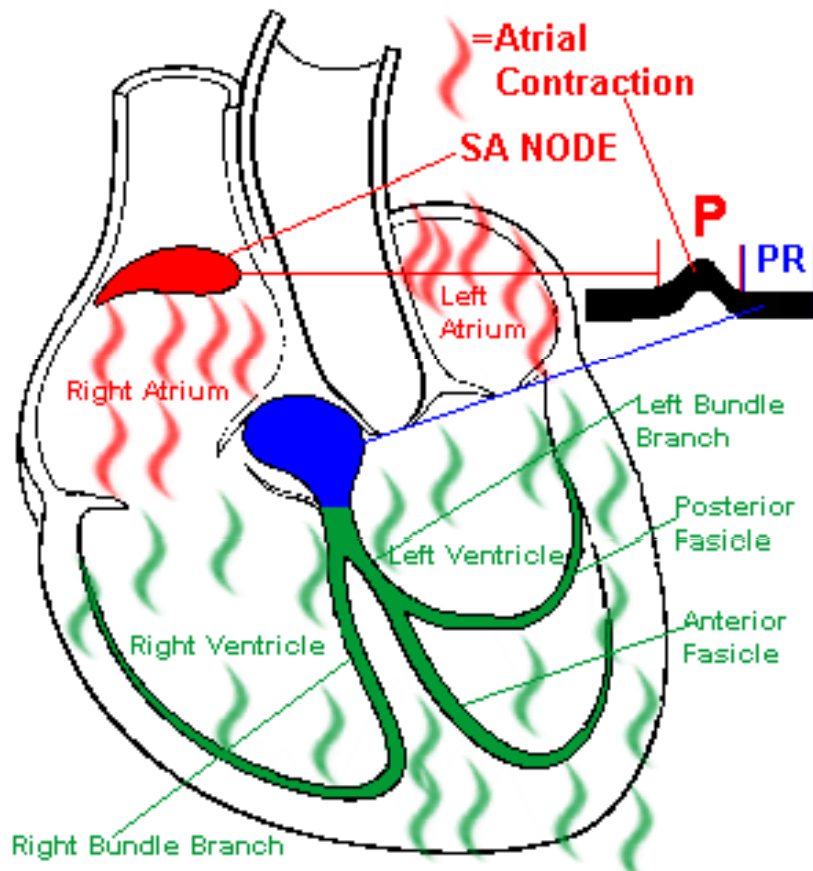

- the atria and the ventricles are separated by nonconductive tissue, with exception of the AV node
- AV node introduces a delay (0.1 s) and ensures atrial contraction before ventricular
- * note that there is a time dependence between the surface ECG and the cardiac conduction system

Action Potentials

- Voltage differences present between the inside and outside of cells
- Membranes create *action potentials* by actively changing their permeabilities to ions such as sodium and potassium
- Swing of about 100 mV between the resting and excited states

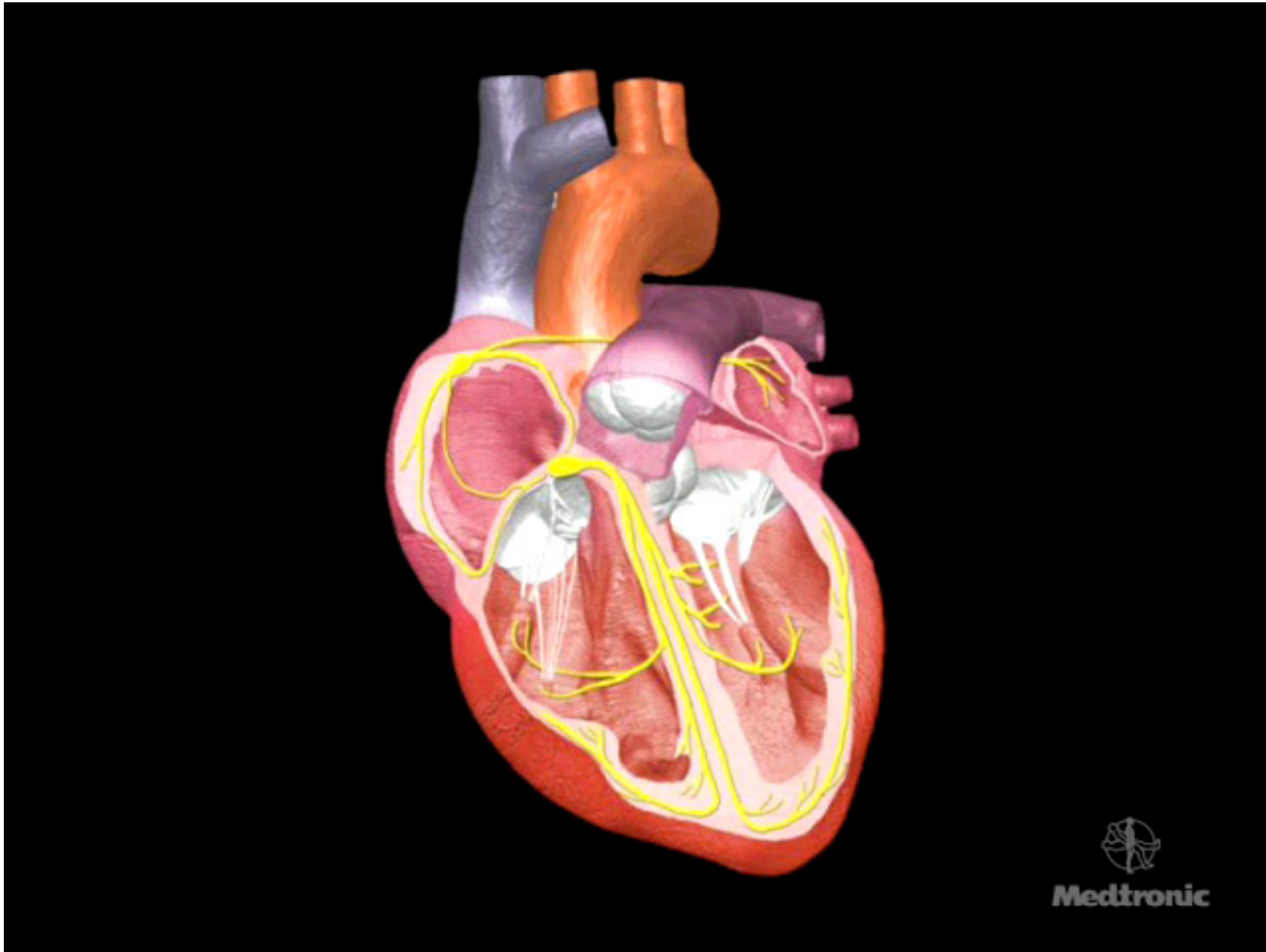

Cardiac Tissue

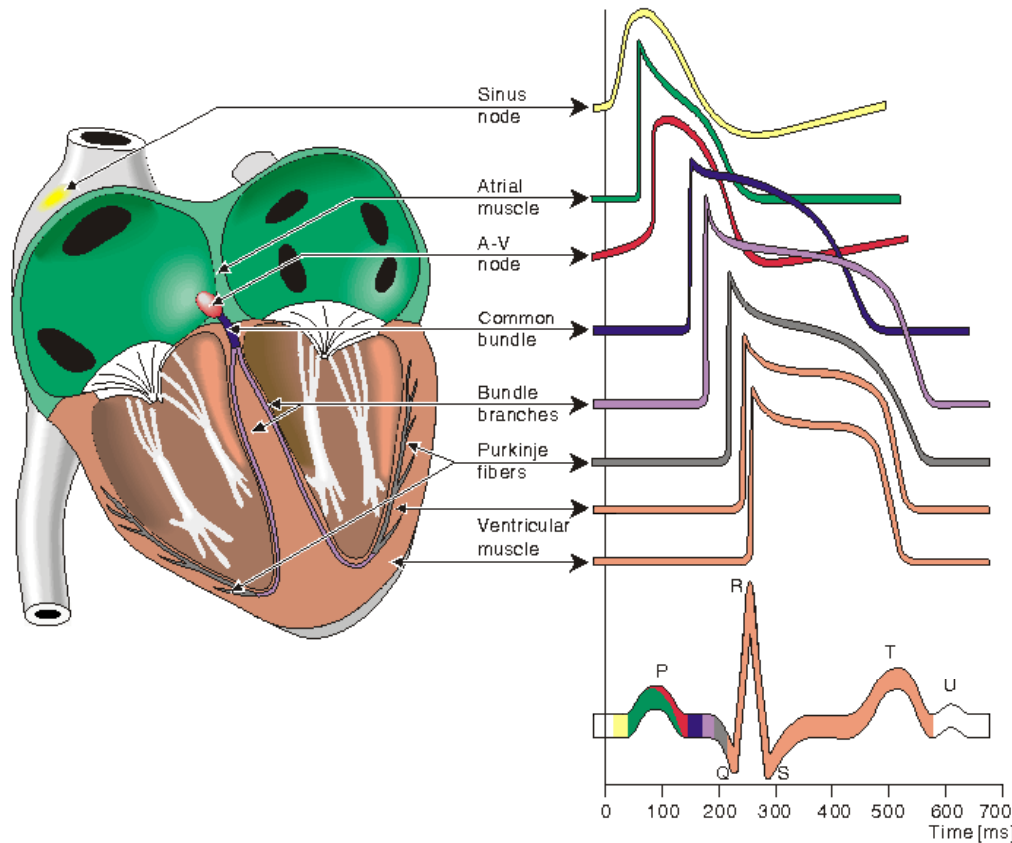

- Different types of heart cells – different characteristics
- Action potentials of the different heart tissue are also different from action potentials of other excitable cells

Pacemaker cell potentials

- some excitable cells spontaneously depolarize and fire action potentials at a regular rate (“internal clock”)
- generation of “pacemaker potentials”
- example: cardiac pacemaker cells of the sinoatrial node in the heart

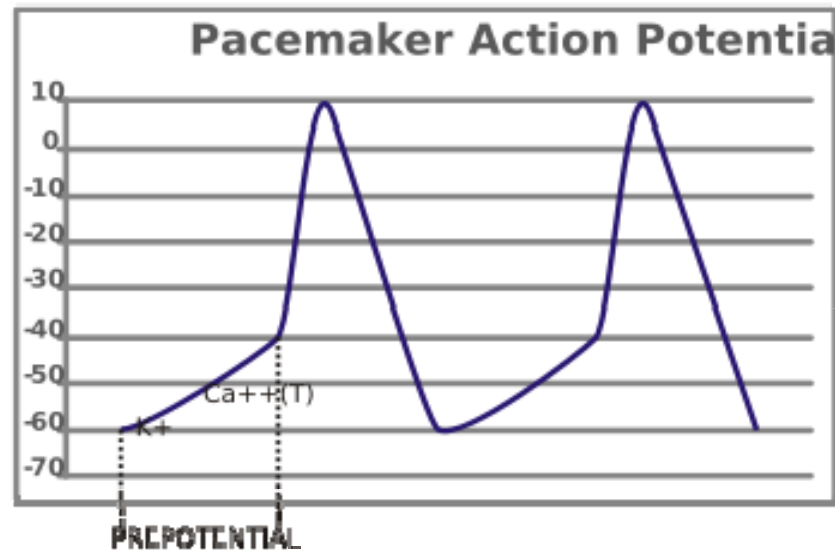

Cardiac action potentials

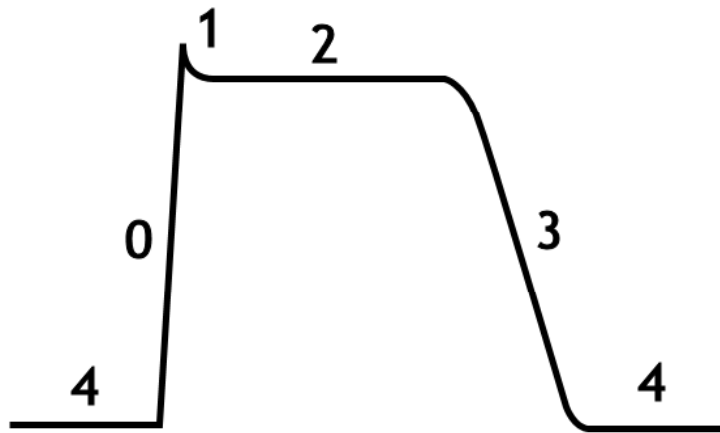

- The cardiac action potential differs from the neuronal action potential by having an extended plateau, in which the membrane is held at a high voltage for a few hundred milliseconds prior to being repolarized

Electrocardiogram (ECG)

Surface ECG

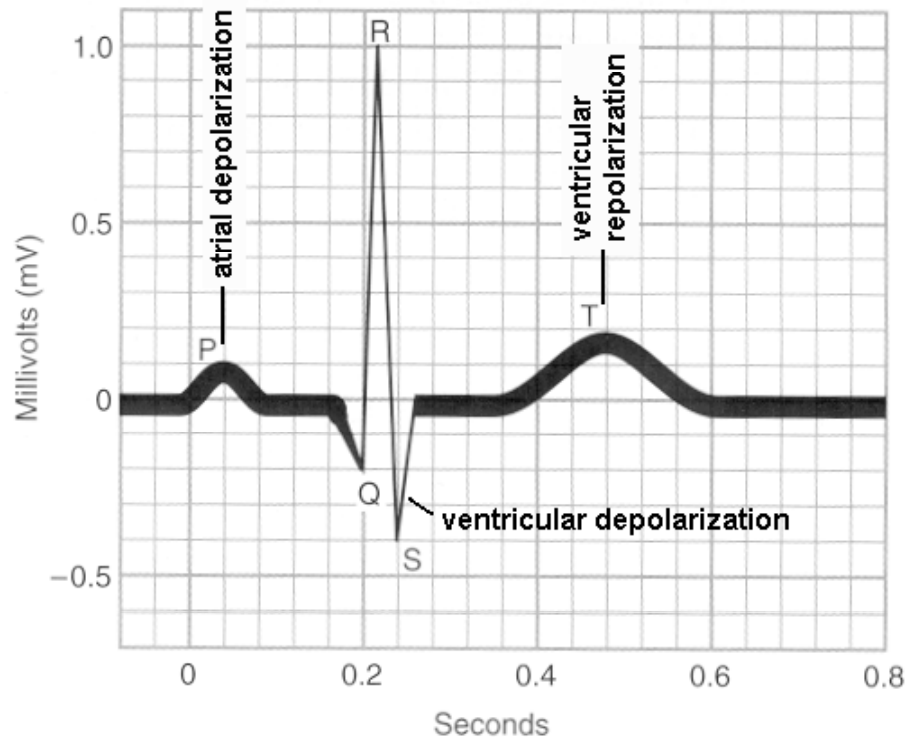

(b) Normal electrocardiogram of a single heartbeat

- a test that records the electrical activity of the heart, shows abnormal rhythms (arrhythmias or dysrhythmias), and detects heart muscle damage

ECG Characteristic Parts

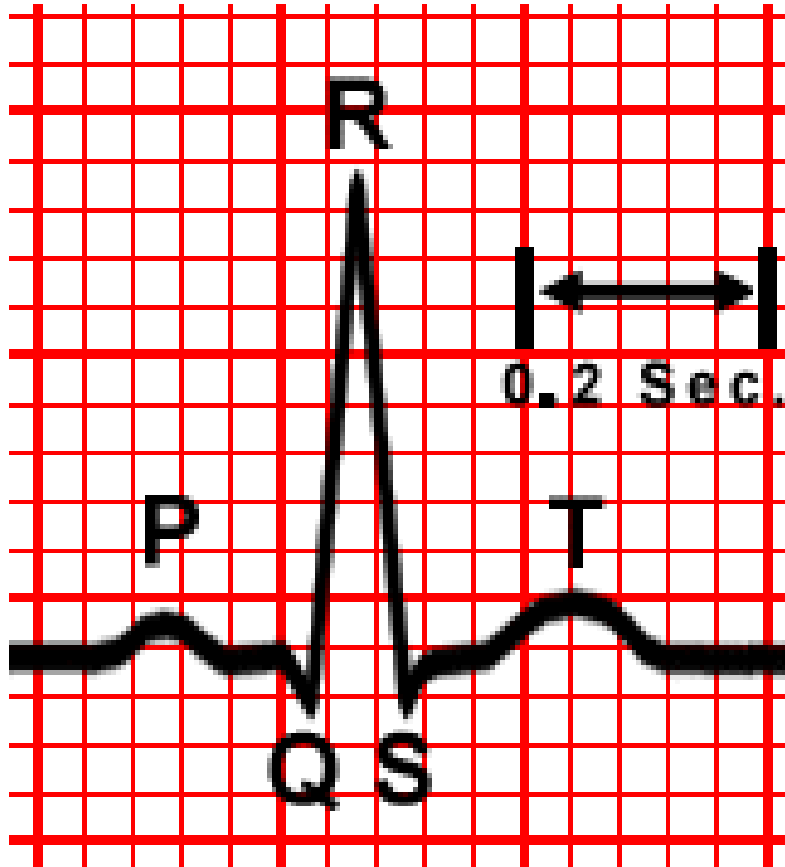

P-wave - depolarisation of atria
($<0,1s$)

PR interval – delay through the AV
node

QRS complex – depolarisation of
the ventricles ($<0,1s$)

T-wave - repolarisation of the
ventricles (approx. $0,3s$)

PQ - interval ($<0,2s$)

QT - interval (depends on HR, at
70 b/min from $0,32s$ to $0,39s$)

Normal Sinus Rhythm

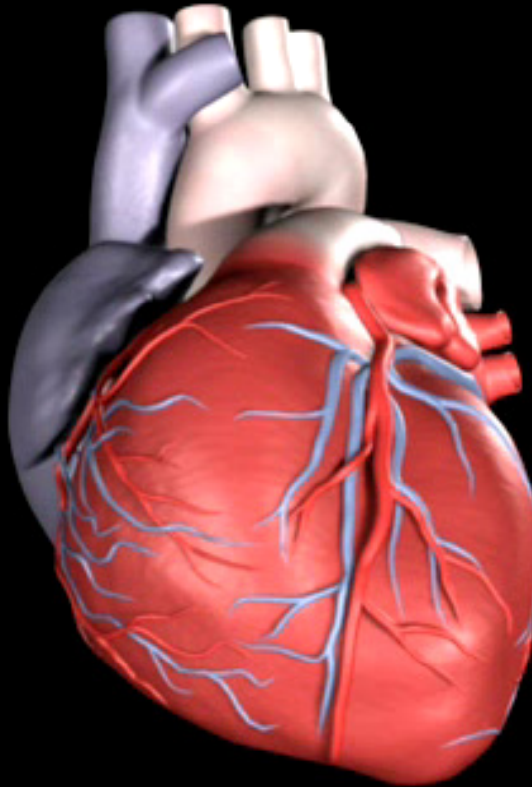

ECG Leads

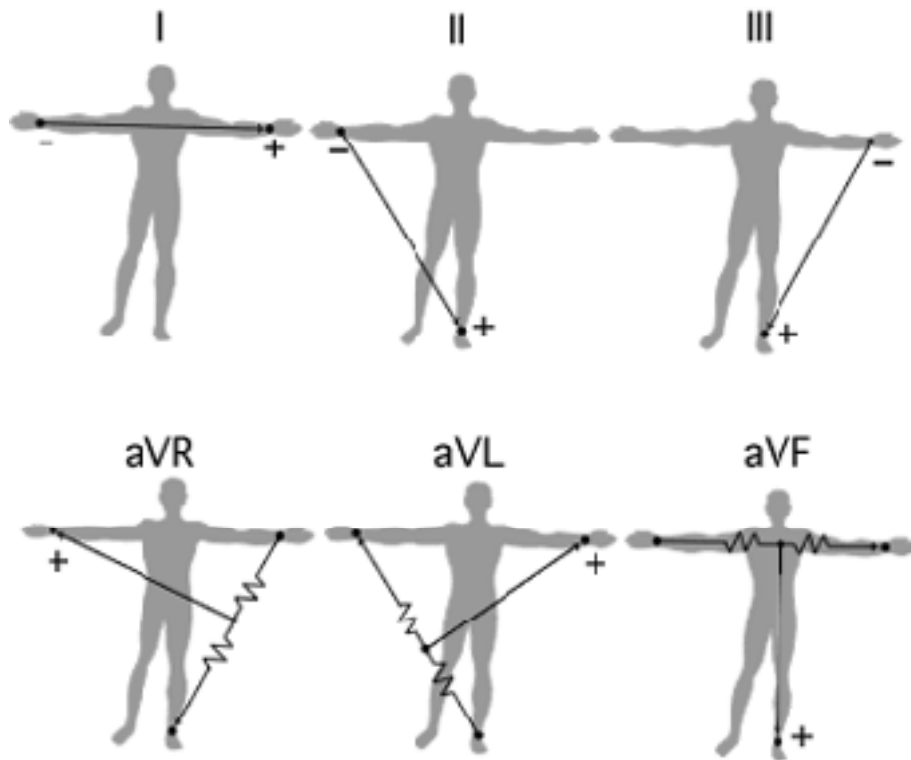

- Standard leads – recorded at the body surface
- Heart – electrical equivalent generator represented as an electrical dipole
- The dipole changes its magnitude and orientation

ECG Notation

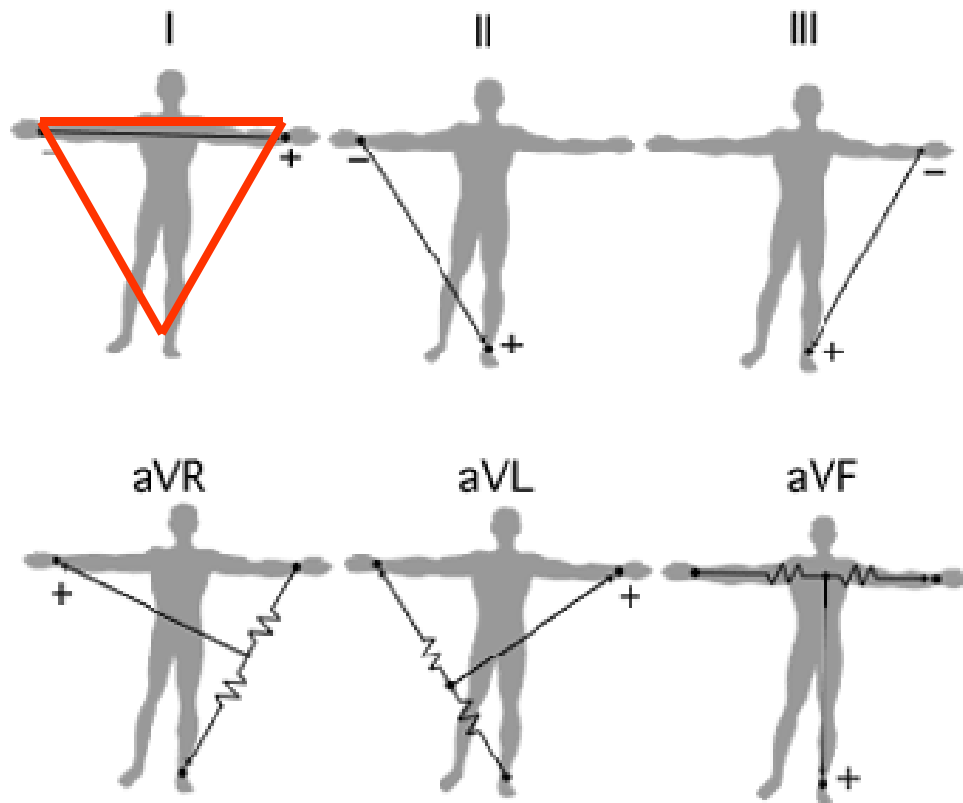

- Standard notation in frontal plane:
- Leads I, II and III are forming the Eindhoven's triangle
- Augmented leads: increase the magnitude of the signal 50%

Precordial leads

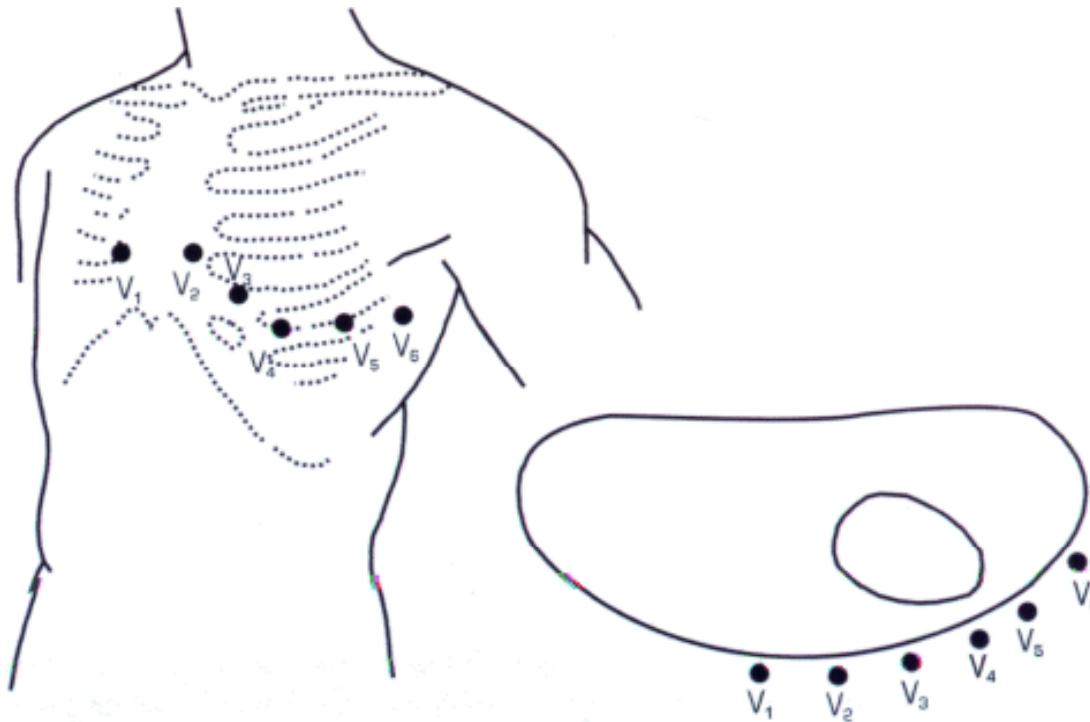

- Position of the precordial leads on the chest wall
- Different “view” on the heart activity

12 channel ECG record

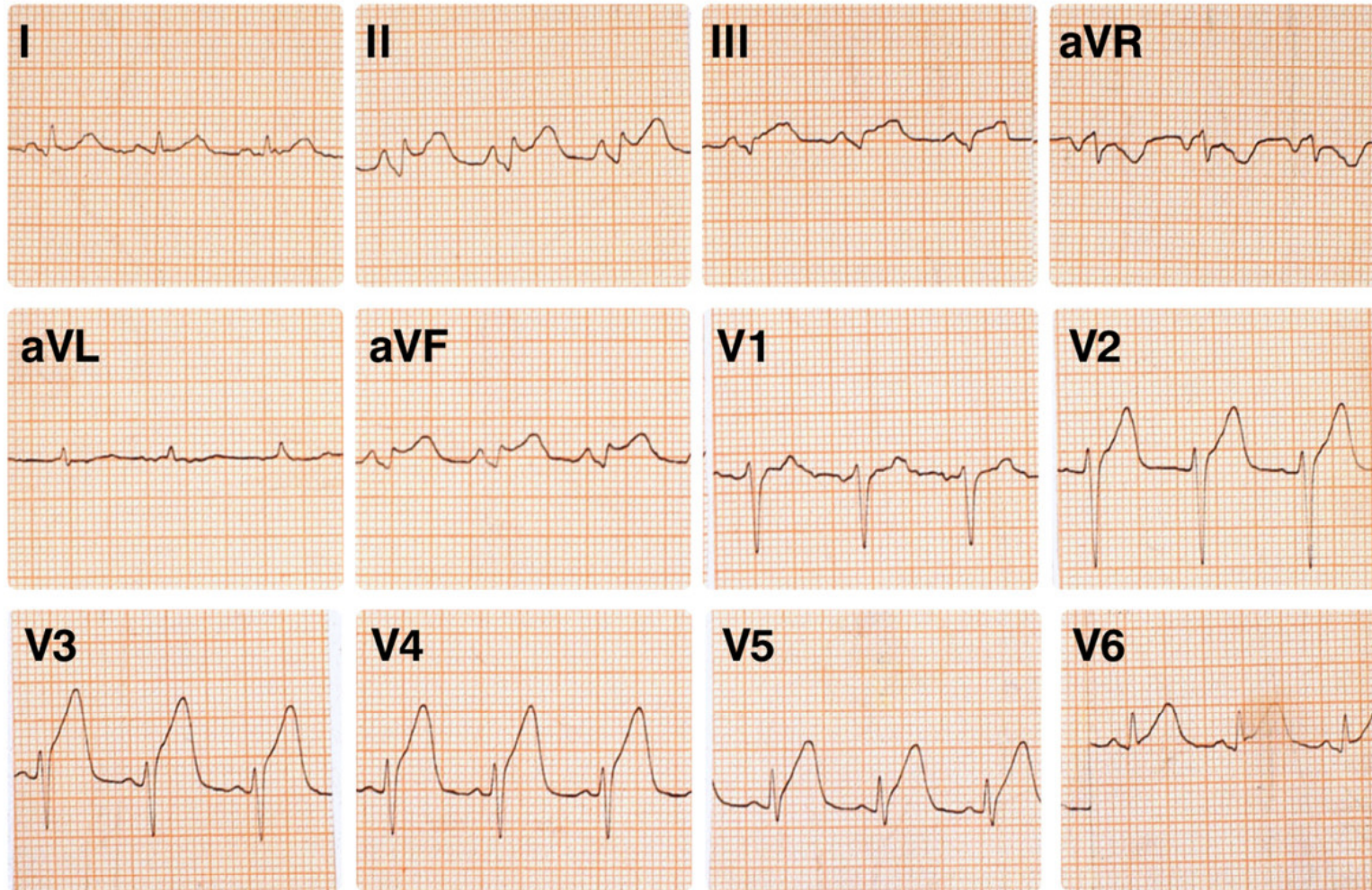

Natural Heart Pacemakers

Sinoatrial node (SA node) - primary heart rate generator (pacemaker); frequency approx. 70/min in static - sino rhythm

Atrioventricular node (AV node) - secondary generator, frequency approx. 40 - 60/min - nodal rhythm

Ventricular conduction system - tertiary generator, frequency approx. 25 - 40/min, not effective enough

Regulation of the Heart Rate

Function of the heart is to provide blood, i.e. oxygen to the body. The amount of blood ejected from the ventricles during one beat is called stroke volume, (SV), and equals approx. 70 ml for each ventricle.

Total amount of blood ejected by heart in one minute is called cardiac output, CO and is

$$\text{CO [l/min]} = \text{SV [l/beat]} \times \text{HR [beats/min]}$$

i.e. approx. 5 l/min; where HR is the heart rate

The number of heart beats is mainly influenced by autonomous nerve system: the sympathetic system accelerates it and parasympathetic system slows it down

Normal Heart Rhythm

- Normal heart rhythm is considered to be approx. 72 b/min in healthy adult persons. In newborn babies, the normal heart rate is 120-160 beats per minute.

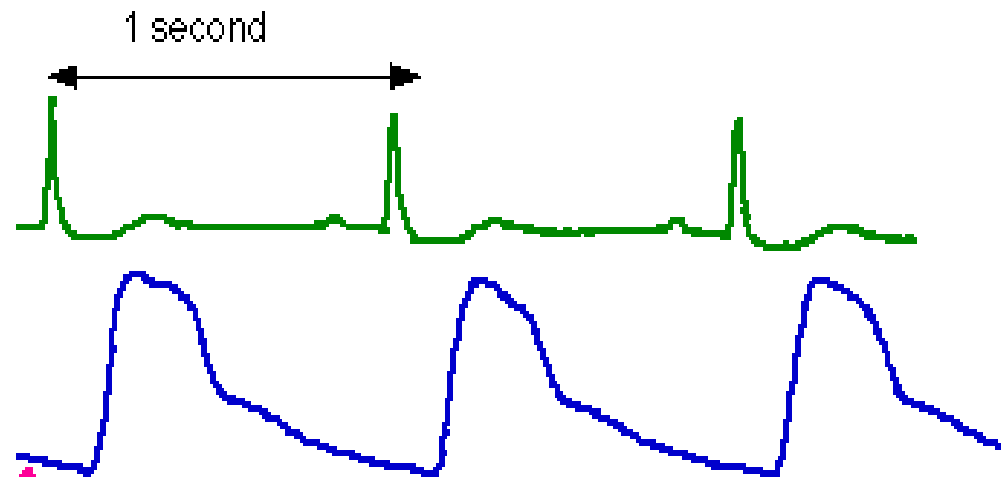

Cardiac Arrhythmias

Normal heart rhythm can be disturbed - arrhythmias appear; in respect to the normal functioning of heart

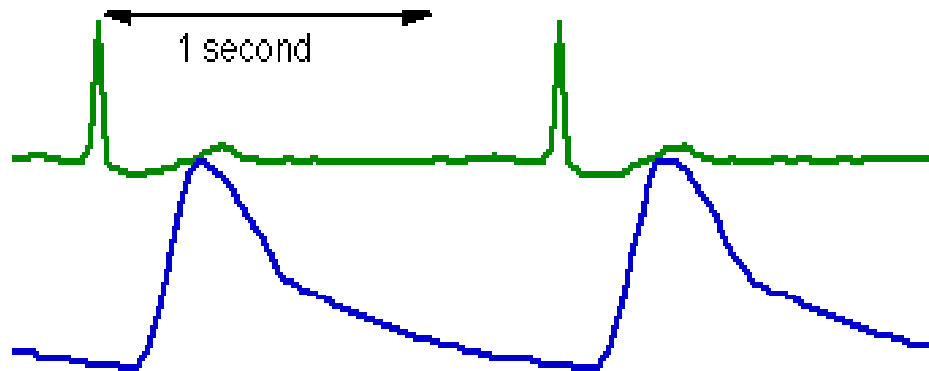

Bradycardia is an abnormally slow heart rate (<60/min at rest)

Cardiac Arrhythmias

Tachycardia is an abnormally fast heart rate (>100/min at rest).

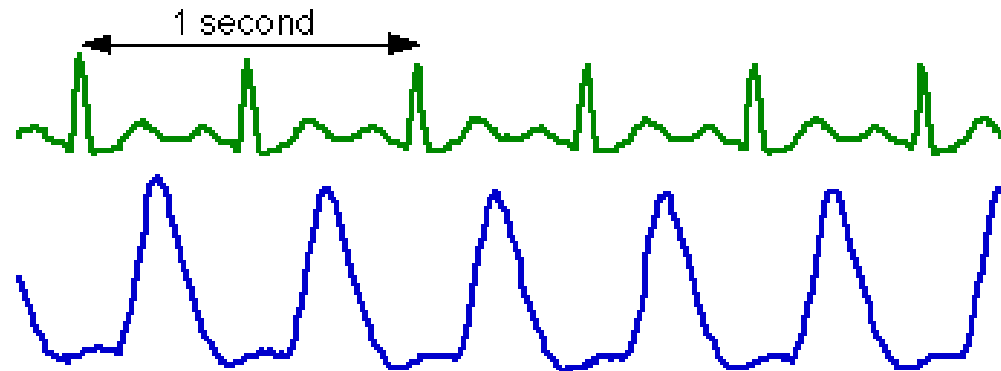

Heart Block

- The signal from the heart's upper to lower chambers may be impaired or doesn't transmit. This is called the "heart block" or the "AV block." This does not necessarily mean that the blood flow is blocked.
- Heart block is classified according to the level of impairment: first-degree, second-degree heart block or third-degree or complete heart block.

Normal Sinus Rhythm

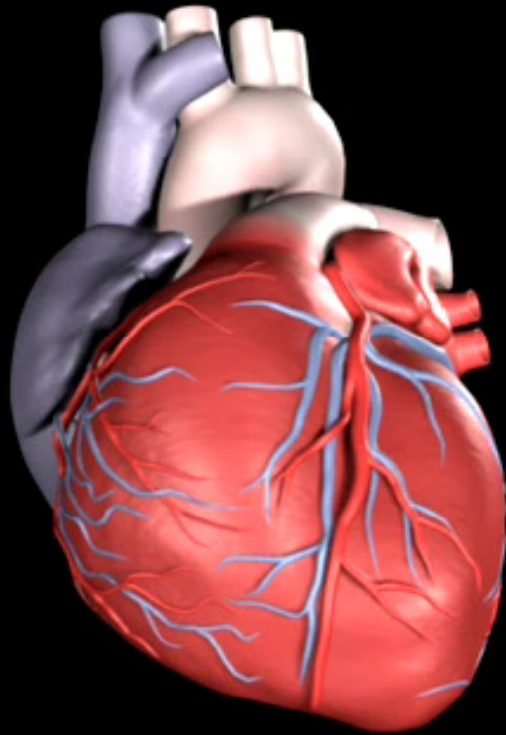

AV Block

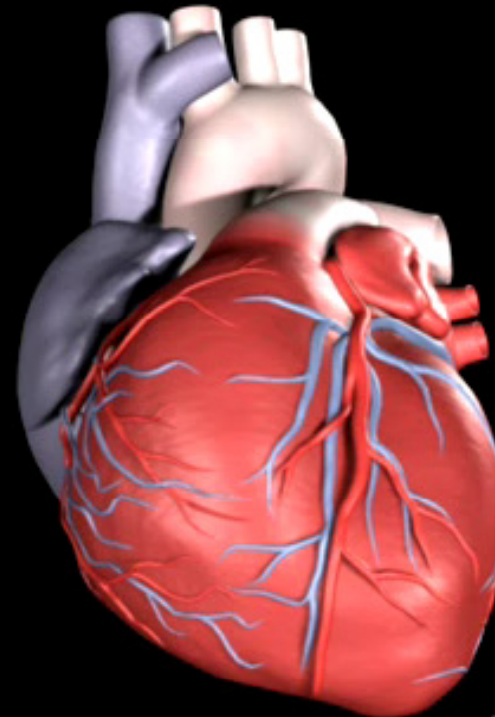

Ventricular Fibrillation

- The heart's electrical activity becomes disordered. When this happens, the heart's lower (pumping) chambers contract in a rapid, unsynchronized way
- Collapse and sudden cardiac death will follow in minutes unless medical help is provided immediately

Ventricular Fibrillation

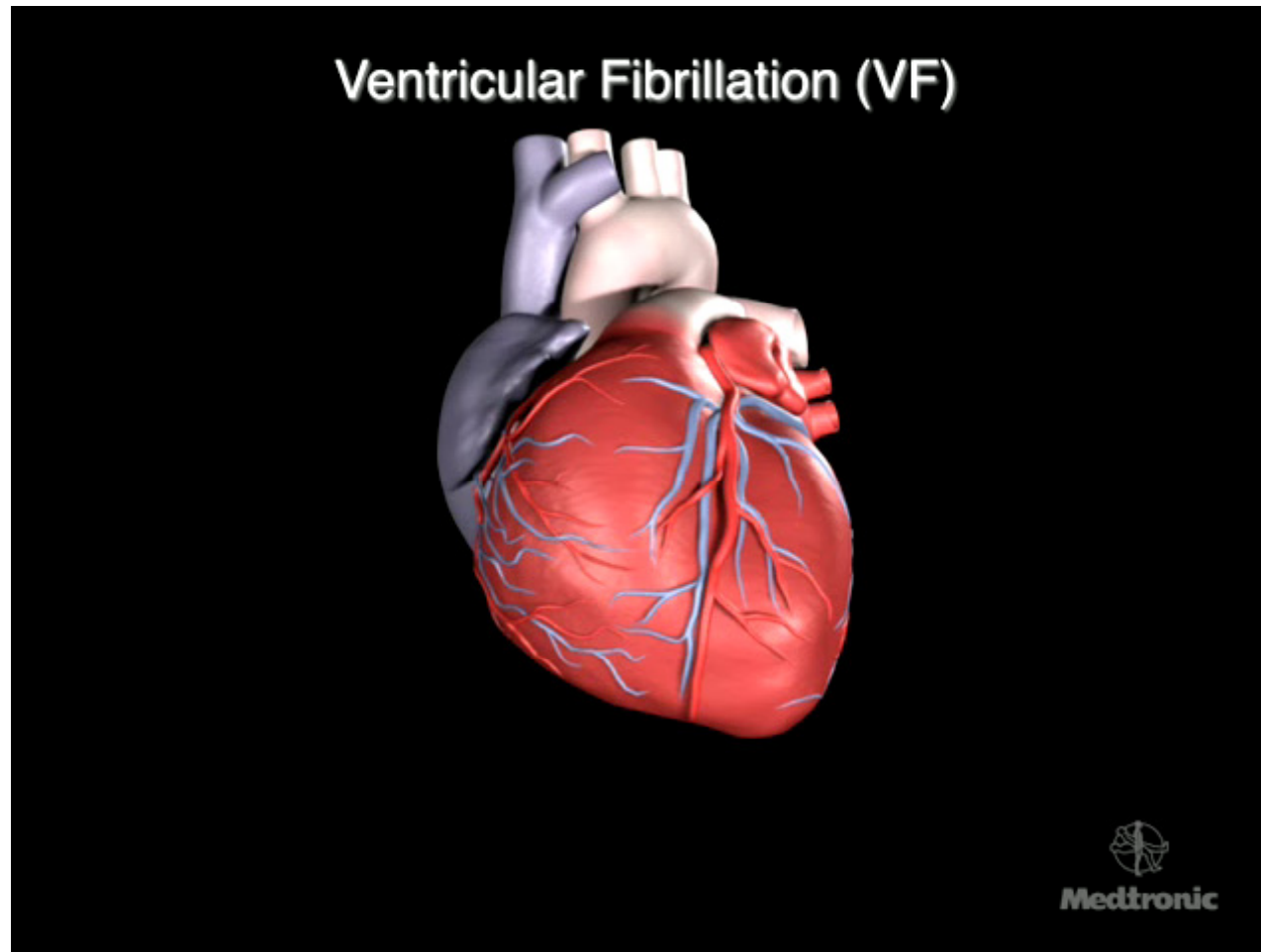

Arrhythmia Classification

- due to **heart rate**: tachycardia and bradycardia
- due to **anatomical position**: ventricular and supraventricular (SA node, atria, AV node)
- due to **electrophysiological mechanism** of their appearance:
 - improper operating of the generator
 - irregularities in conducting impulses (heart block, reentry, etc)

Electrocardiograph

- The apparatus that records the ECG is called the electrocardiograph
- If a patient needs continuous monitoring during hospitalization, the ECG is “monitored” on a ECG monitor

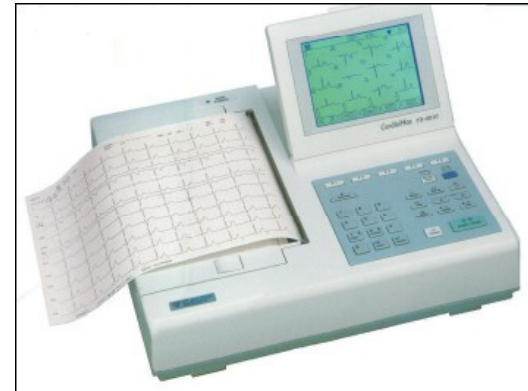

ECG Amplifier

- The most important part of any equipment recording bioelectric potentials is the input amplifier
- Most important characteristics:
 - High gain
 - High common mode rejection ratio (CMRR)
 - Frequency range typically from 0,02 Hz to 150 Hz
 - Very high input impedance
 - Low noise

Instrumentation Amplifier

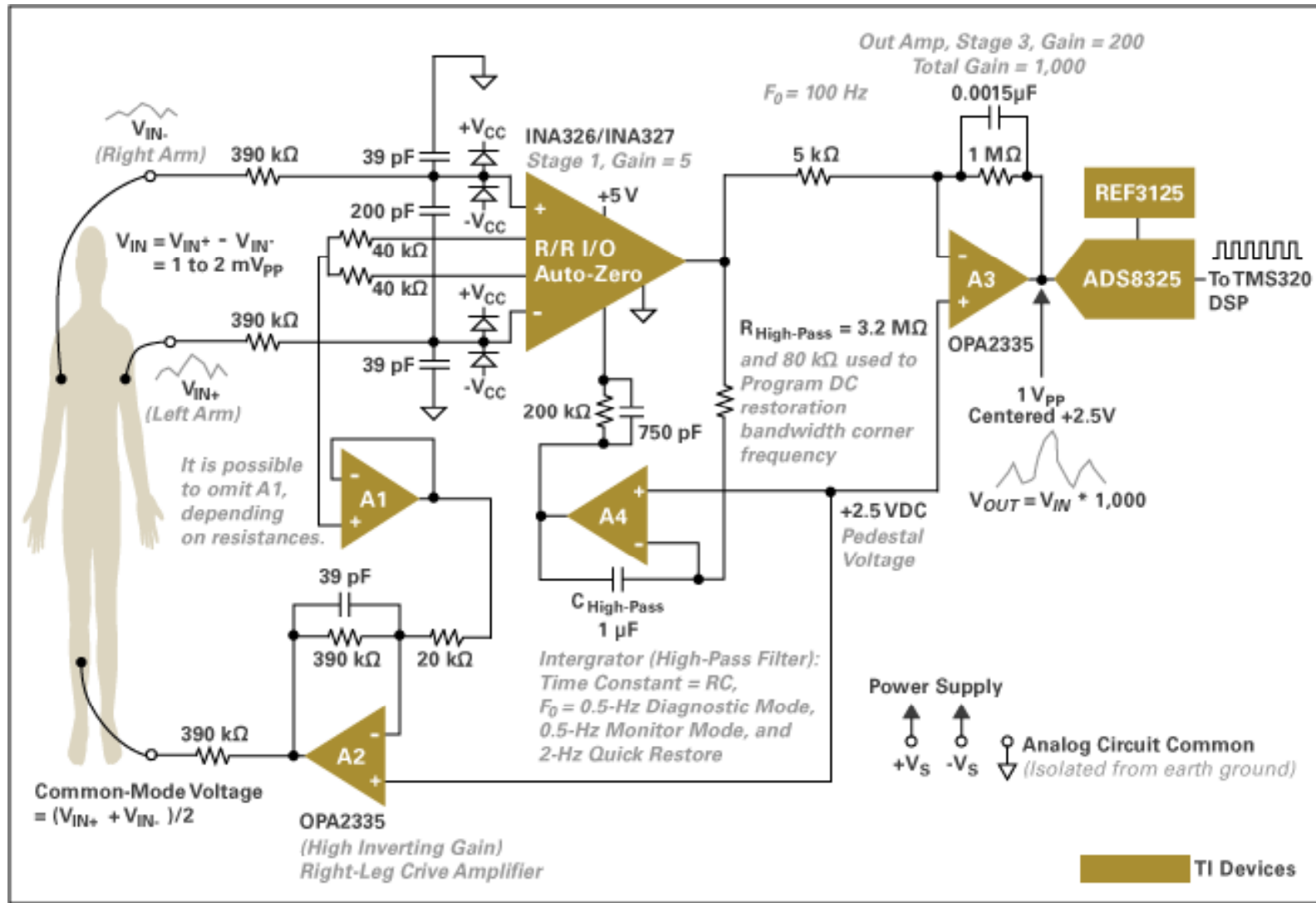

Symplified ECG Block Diagram

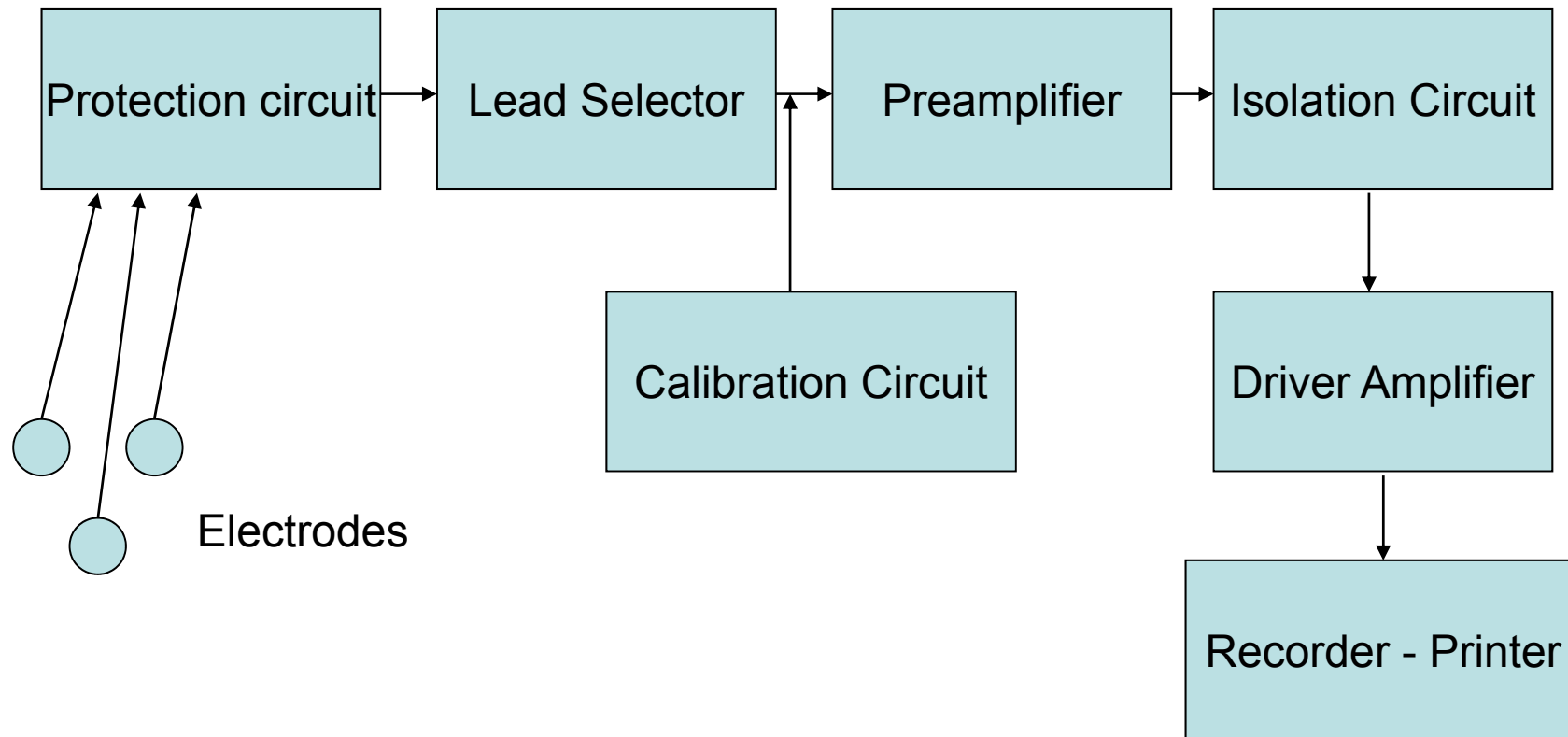

ECG Schematic Diagram

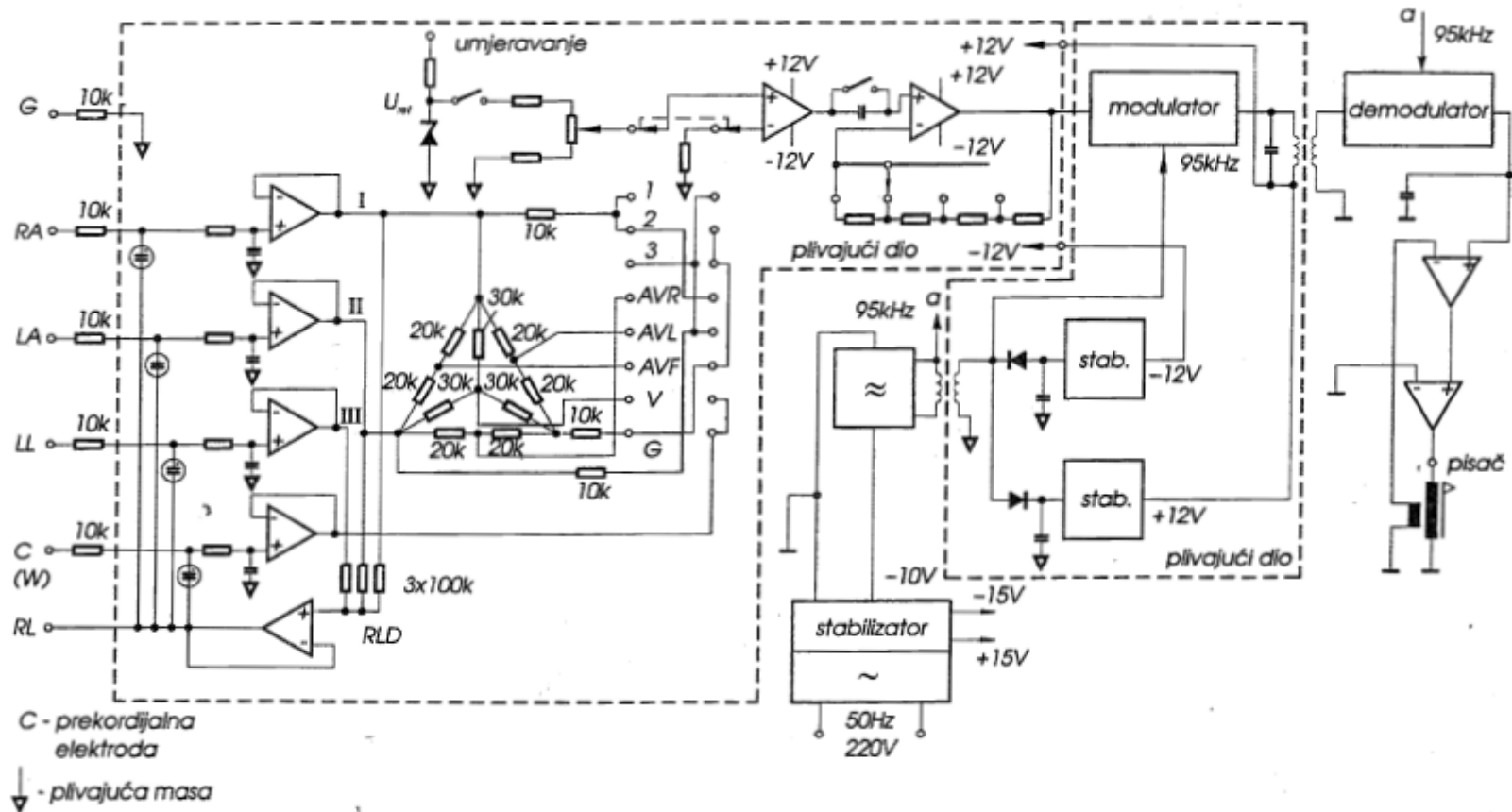

Single channel ECG

Source: A. Šantić, Biomedicinska elektronika, Školska knjiga, Zagreb

QRS detector structure

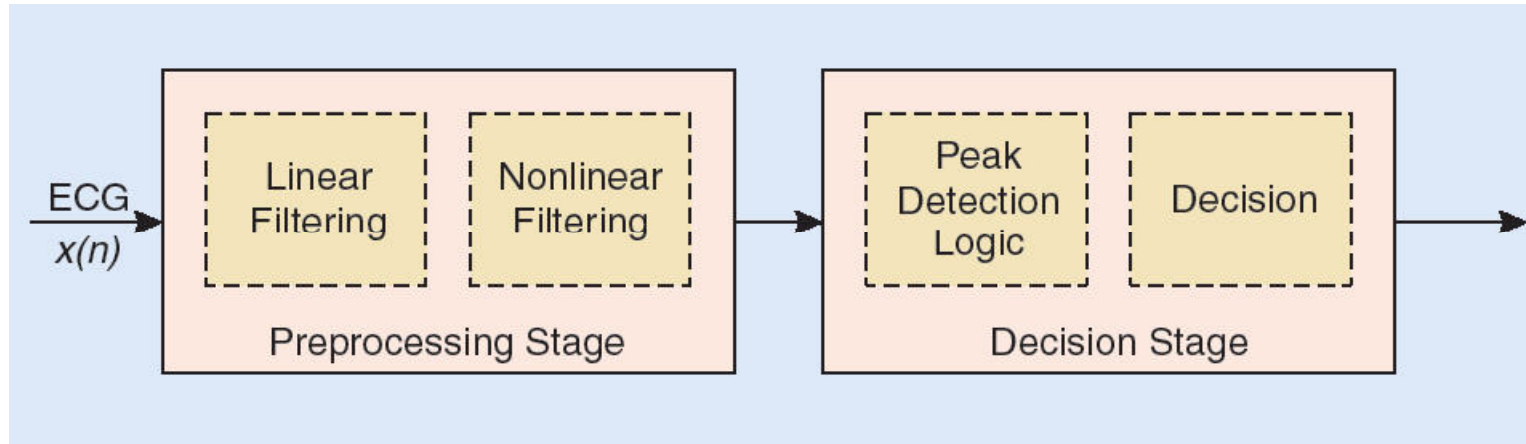

- QRS detectors can be used:
 - HR monitoring
 - synchronization of the pacemakers

ECG spectrum

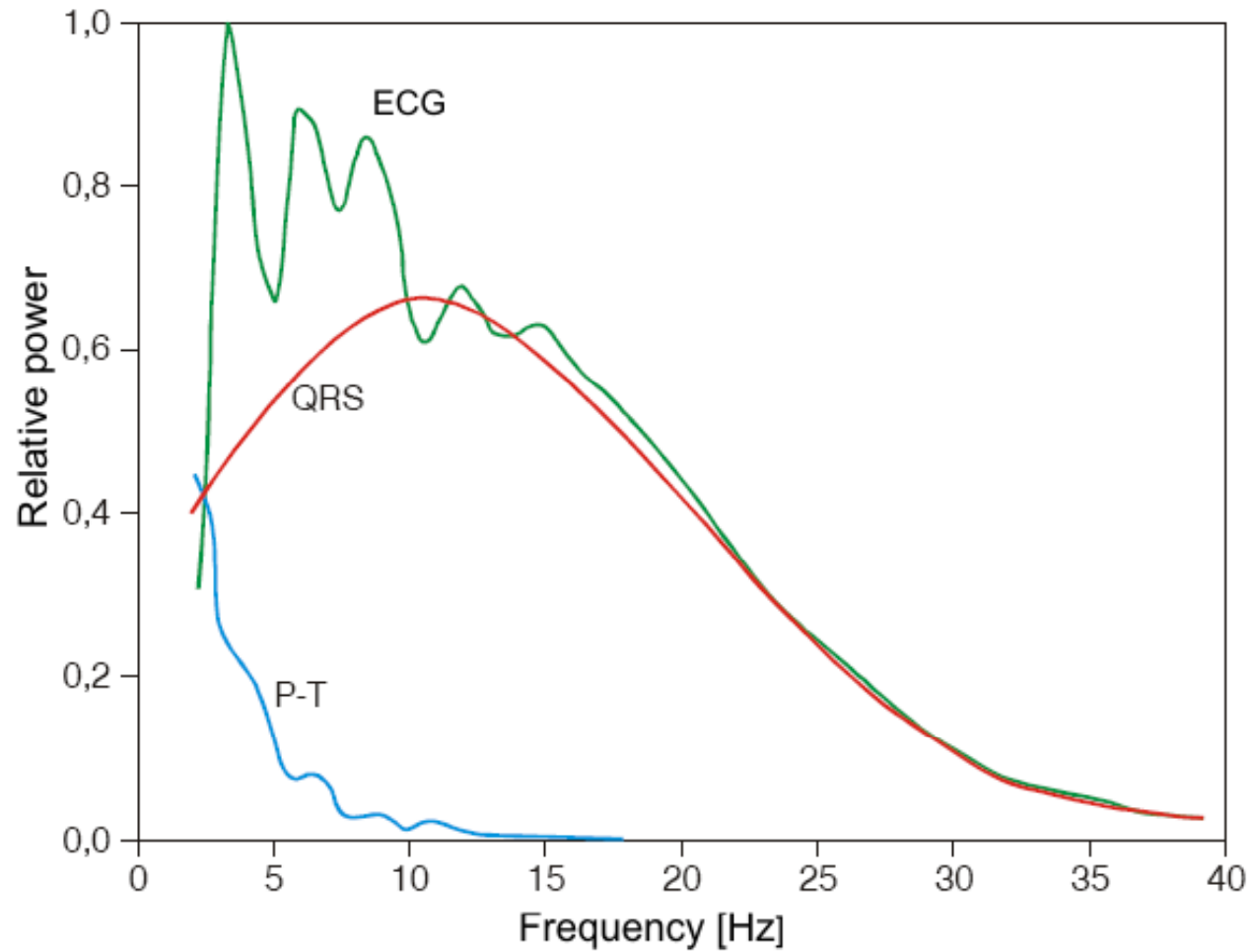

Performance evaluation

- ANSI/AAMI EC57 standard

- *sensitivity*

- *positive predictive value*

$$S = \frac{TP}{TP + FN}$$

$$PP = \frac{TP}{TP + FP}$$

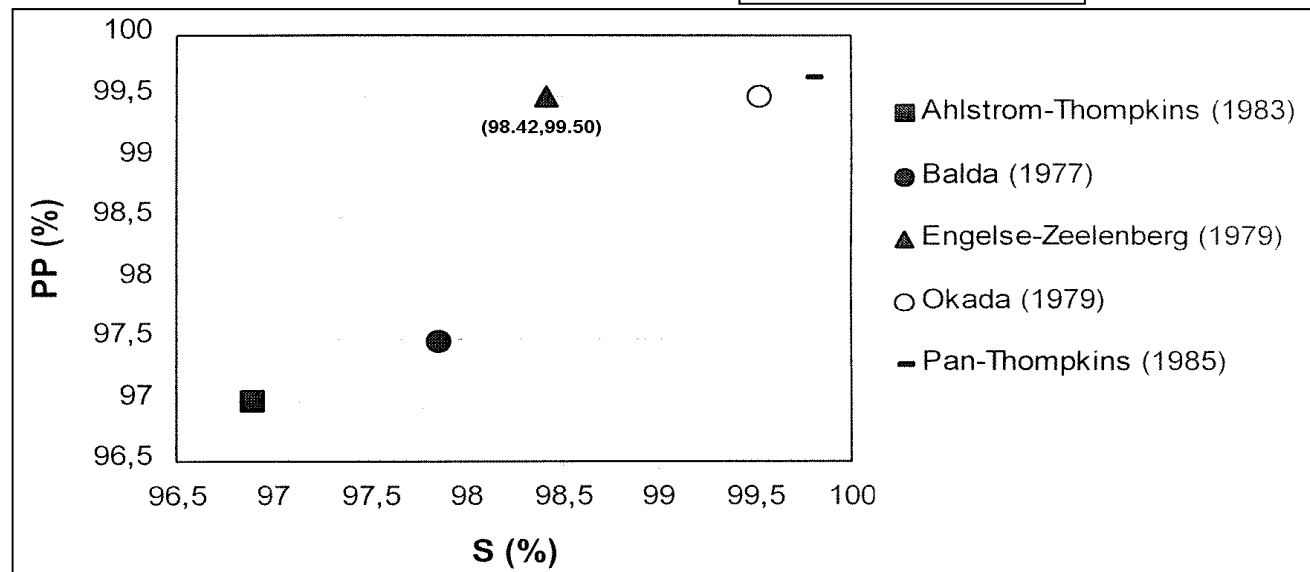

Diagnosics and therapy of the
Heart, 2009

Literature

- Brown, B.H. et al., “Medical Physics and Biomedical Engineering”., IoP Publishing, London, reprinted 2001.
- Webster, J.G. (Ed.), “Medical Instrumentation, Application and Design.” 2nd ed., J. Wiley & Sons, Inc., New York, 1995.
- Nelson, C.V., Geselowitz D.B., ur.: “The Theoretical Basis of Electrocardiography”. Claredon Press, 1976.
- Webster, J.G. (Ed.), “Bioinstrumentation”. John Wiley & Sons, Inc., New York, 2003

In Croatian:

- Šantić, A., “Biomedicinska elektronika”, Školska knjiga, Zagreb, 1995