

# Sigurnost nuklearnih elektrana

Predavač:  
Davor Grgić

Organizator:  
**IEEE PES i IEEE Student Branch Zagreb**  
Zagreb 2008



# Da li su NE sigurne?

- Mogući odgovori:
  - Ne, to su tempirane atomske bombe
  - Da, produkt su suvremene tehnologije i svaka moguća nesreća je uzeta u obzir
  - Da, ali obzirom na prirodu procesa stanoviti rizik je prisutan
- U čemu je opasnost?
- Što je s drugim energetskekim izvorima, da li se rizik isplati?
- Zašto zadnje vrijeme češće govorimo o nuklearnim elektranama?

# Pod kojim uvjetima je rad nuklearnih elektrana prihvatljiv?

- NE moraju biti sigurne i pouzdane (nove generacije elektrana unapređuju ionako pouzdanu tehnologiju, ali se javlja problem terorizma)
- NE moraju biti konkurentne (porast cijene fosilnih goriva, njihova moguća nestašica, utjecaj na okoliš i eksterni troškovi zajedno s povećanom raspoloživošću kompenziraju velike investicijske troškove)
- Potrebno je riješiti problem istrošenog goriva (problem je tehnički rješiv i radi se na par demonstracijskih projekata, transmutacija bi mogla bitno popraviti situaciju)
- Spriječiti proliferaciju nuklearnog materijala (uglavnom političko pitanje i nije nužno vezano za energetska primjenu)

# Kako spomenuti faktori utječu na NE? (Nuklearne elektrane u SAD 1953-2005)

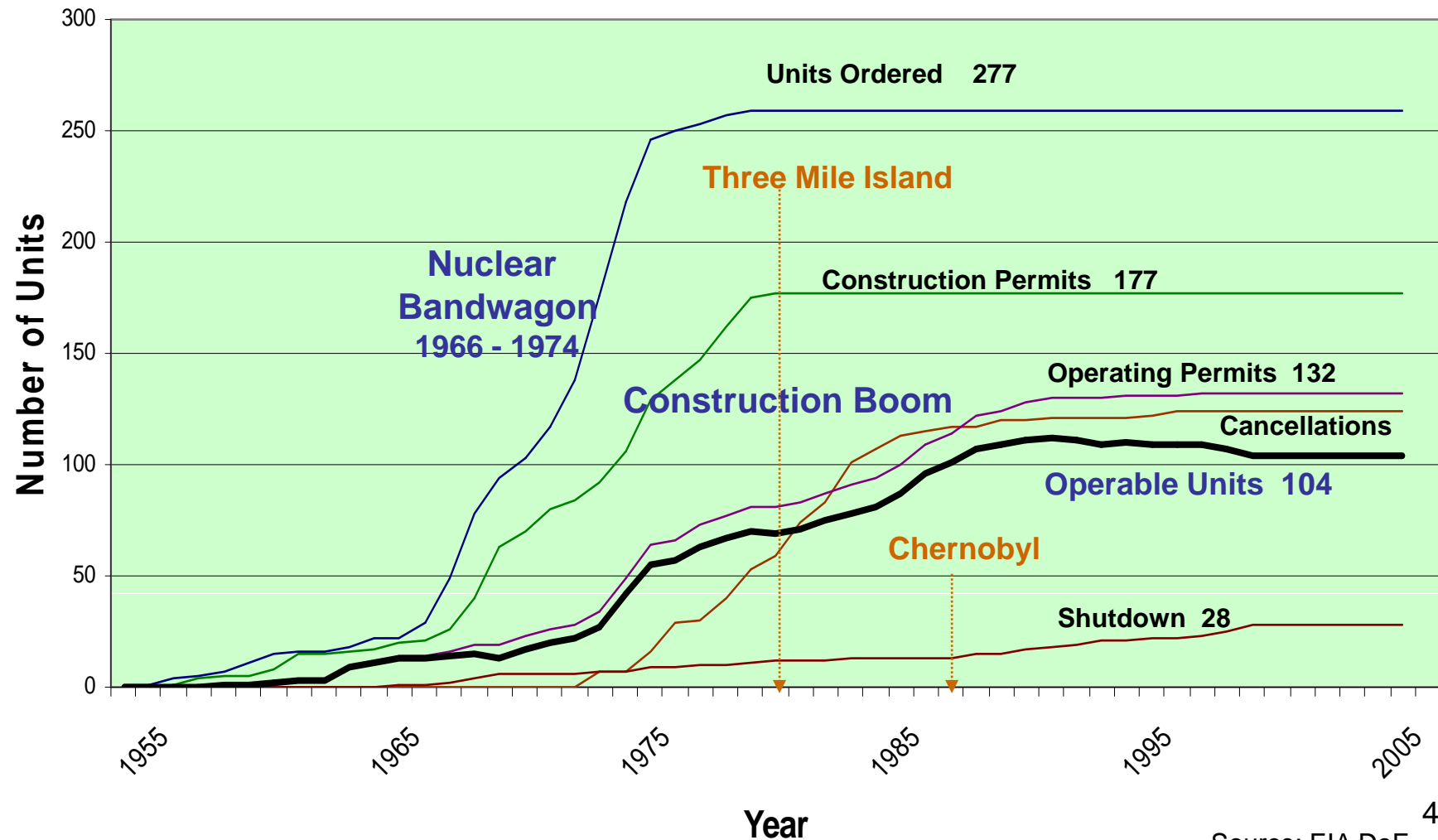

Source: EIA DoE

# Sigurnost i isplativost NE u zadnjih 10 godina

Relative Cost  
Risk (CDF)

Capacity Factor

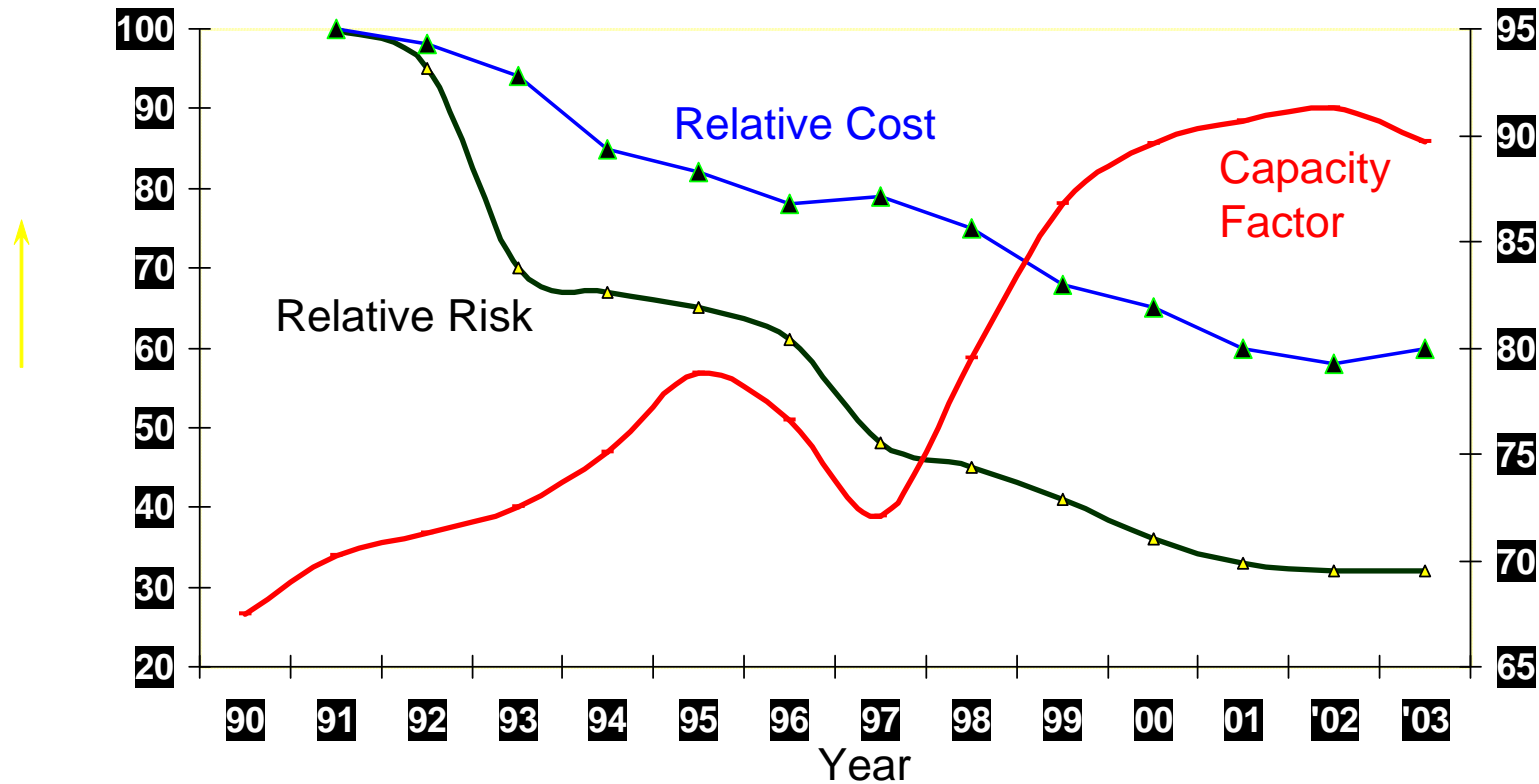

Based on UDI, DOE & NUS Data plus info. from ERIN Eng & EPRI

## Broj neuobičajenih događaja prijavljen NRC (1989-2003)

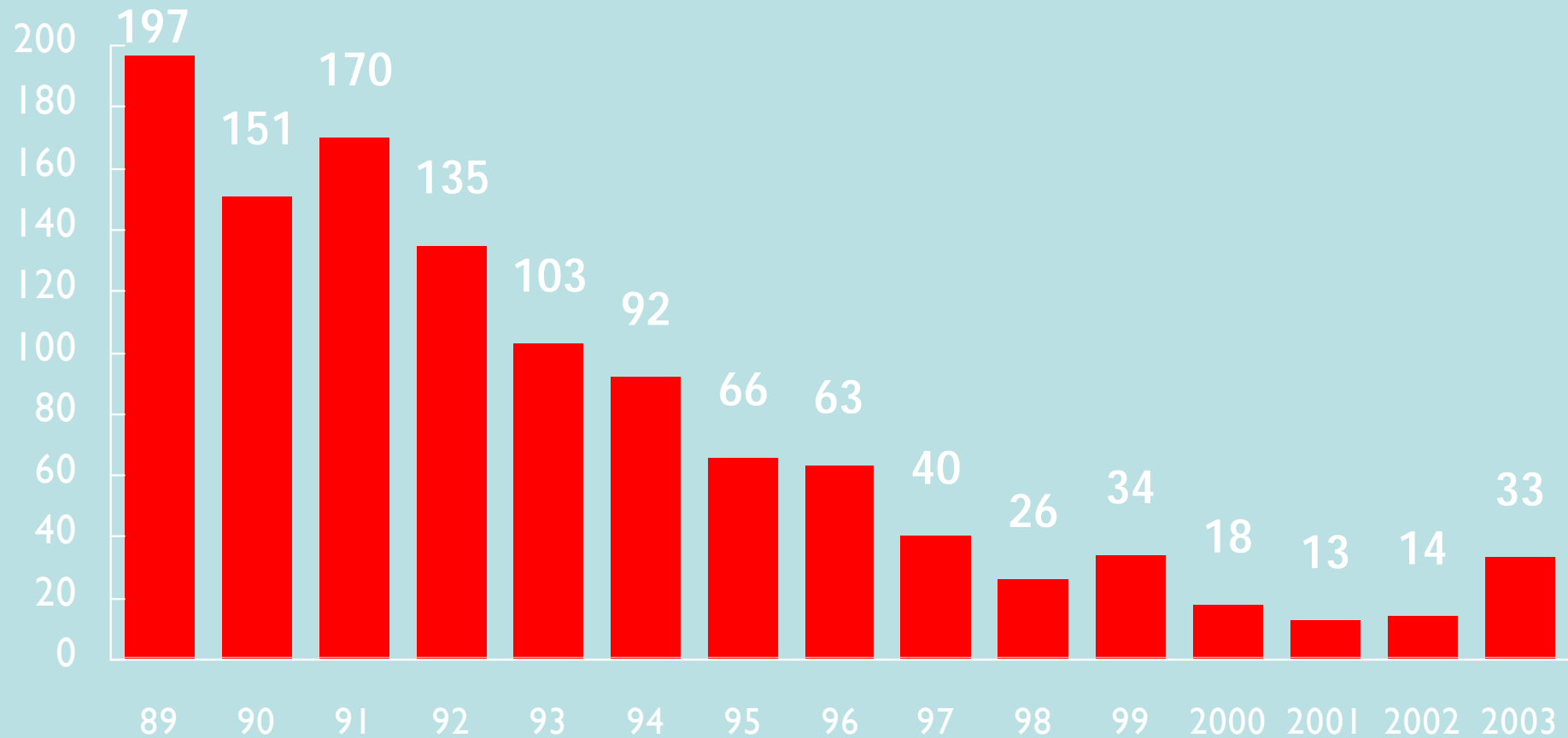

Source: SCIENTECH - Updated 06/04

**Note:** A Notification of Unusual Event for power and non-power reactor licensees is a condition involving potential degradation of the level of plant safety that does not represent an immediate threat to public health and safety.

# Broj neplaniranih brzih obustava

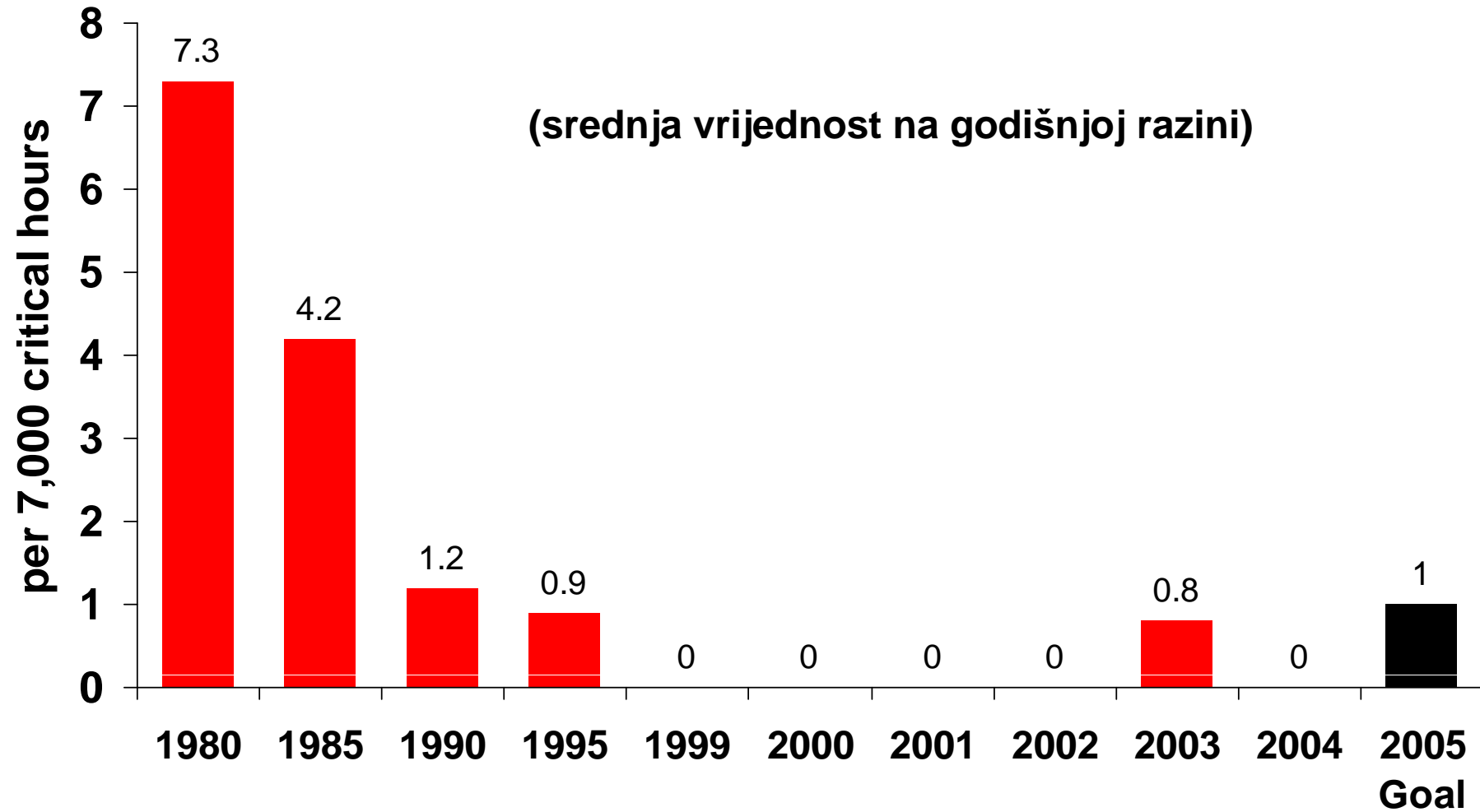

Source: WANO

# Broj industrijskih nesreća s nepovoljnim posljedicma na 200000 radnih sati

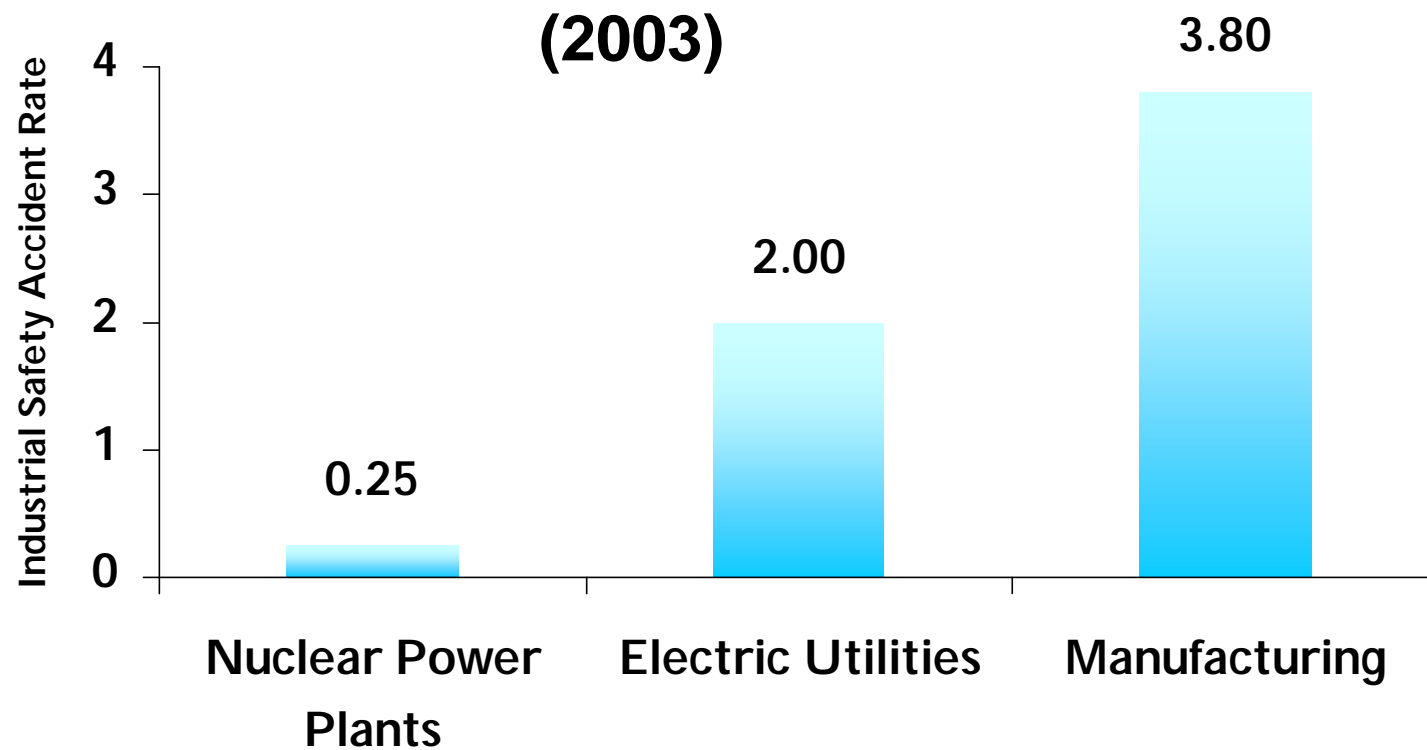

ISAR = number of accidents resulting in lost work, restricted work, or job transfer per 200,000 worker hours  
Sources: Nuclear (World Association of Nuclear Operators), others (US Bureau of Labor Statistics). Data updated April 2005



# U.S. Nuclear Industrial Safety Accident Rate

One-Year Industry Values

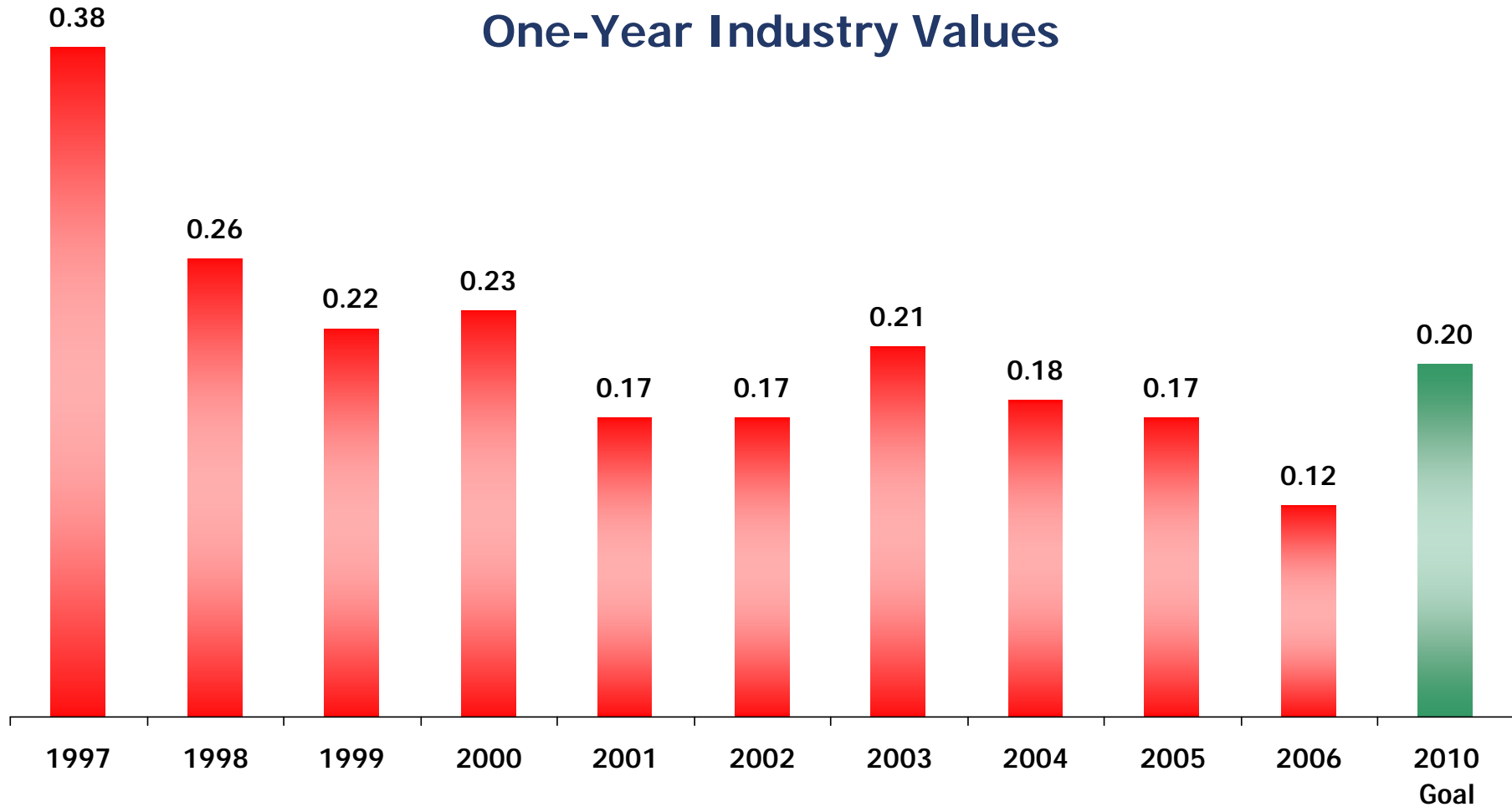

ISAR = Number of accidents resulting in lost work, restricted work, or fatalities per 200,000 worker hours.

Source: World Association of Nuclear Operators

Updated: 4/07

# Environmental effects of fossil fuels compared to nuclear

## •*Fossil fuels*

- Global climate change
- Air quality degradation (coal, oil)
- Lake acidification and forest damage (coal, oil)
- Toxic waste contamination (coal ash and slag, abatement residues)
- Groundwater contamination
- Marine and coastal pollution (oil)
- Land disturbance
- Large fuel and transport requirements
- Resource depletion

## •*Nuclear (full energy chain)*

- Severe reactor accident release
- Waste repository release

## •*Hydroelectric*

- Population displacement
- Land loss and change in use
- Ecosystem changes and health effects
- Loss of biodiversity
- Dam failure
- Decommissioning

## •*Renewables*

### *(solar, wind, geothermal, biomass)*

- Air quality degradation (geothermal, biomass)
- Extensive land use
- Ecosystem changes
- Fabrication impact (solar photovoltaic cells)
- Noise pollution (wind)

# Potrošnja goriva u NE i TE

- Needed Fuel for operation of 1,000MWe power plant:
  - Nuclear Power Plant : 30 Ton
    - Truk : 3
  - Gas Power Plant : 1.1 M Ton
    - Liquid Gas Ship : 16
  - Oil Power Plant : 1.4 M Ton
    - Big Oil Tanker Ship : 7
  - Coal Power Plant : 2.3 M Ton
    - Big Coal transportation Ship : 23

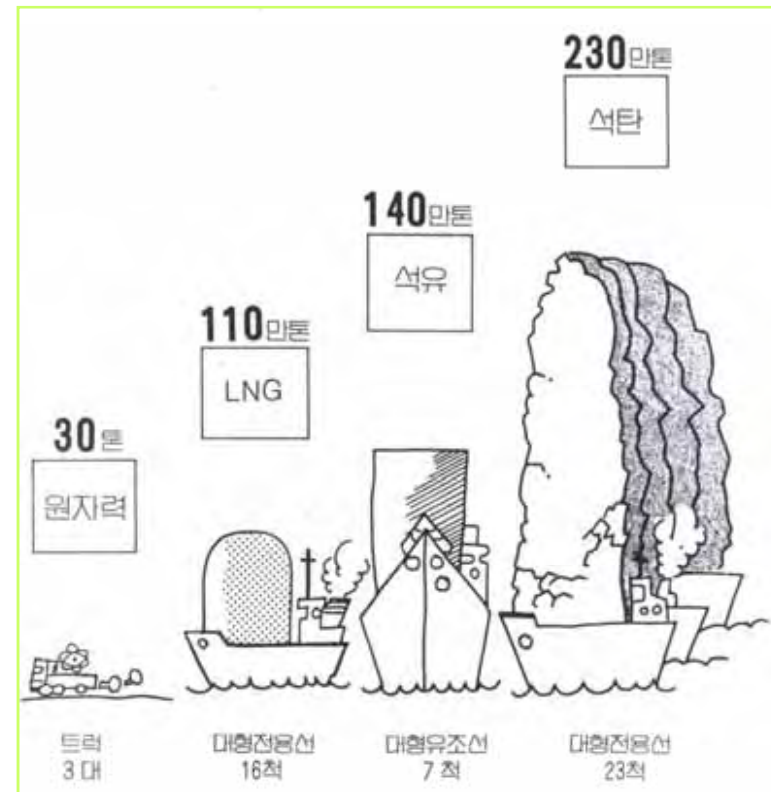

# CARBON DIOXIDE EMISSIONS

## Construction/Operation/Fuel Preparation

(kg CO<sub>2</sub> / kWh)

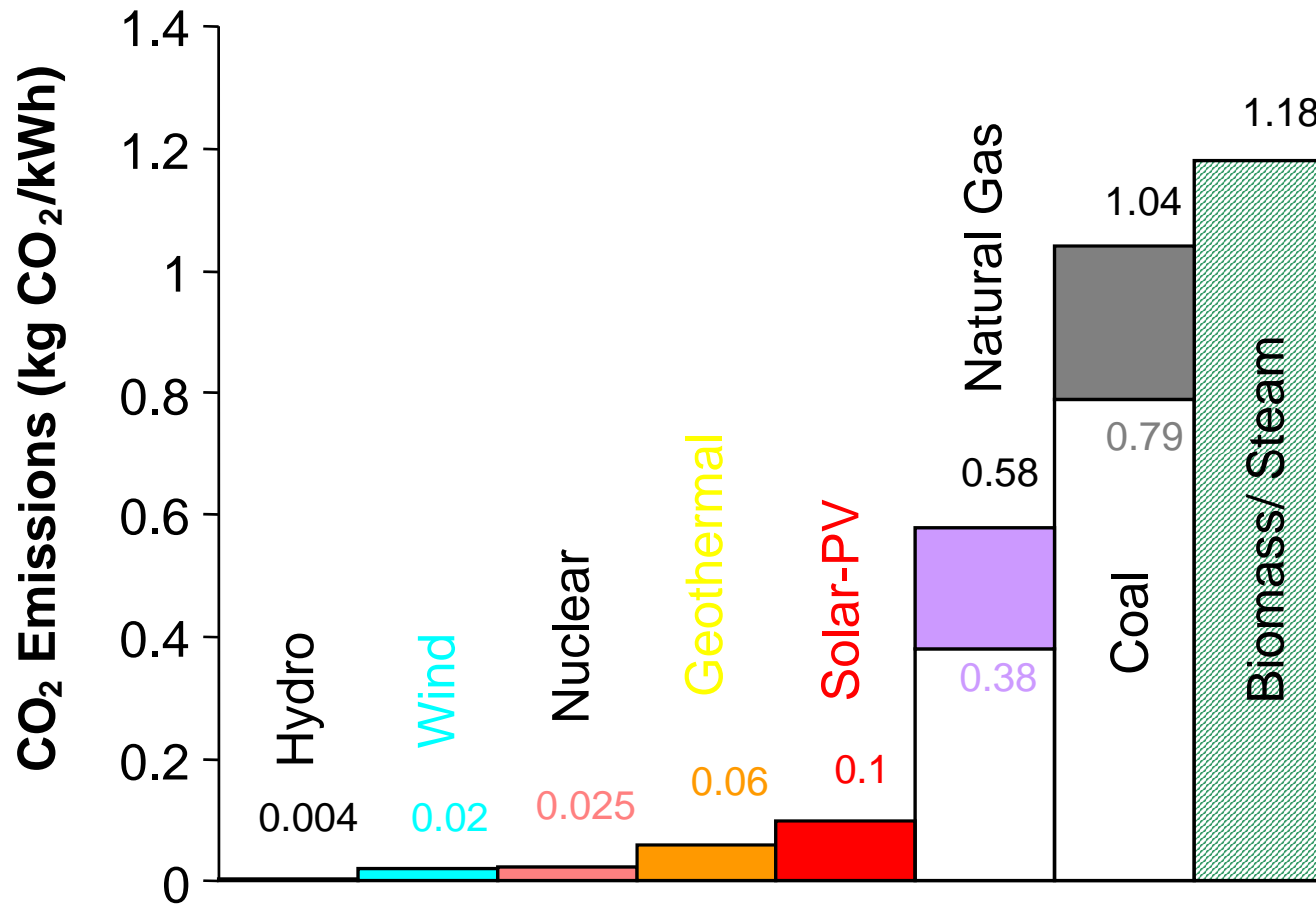

# Greenhouse Gas Emissions from Electricity Production Chains (gCO<sub>2</sub> equiv./kWh)

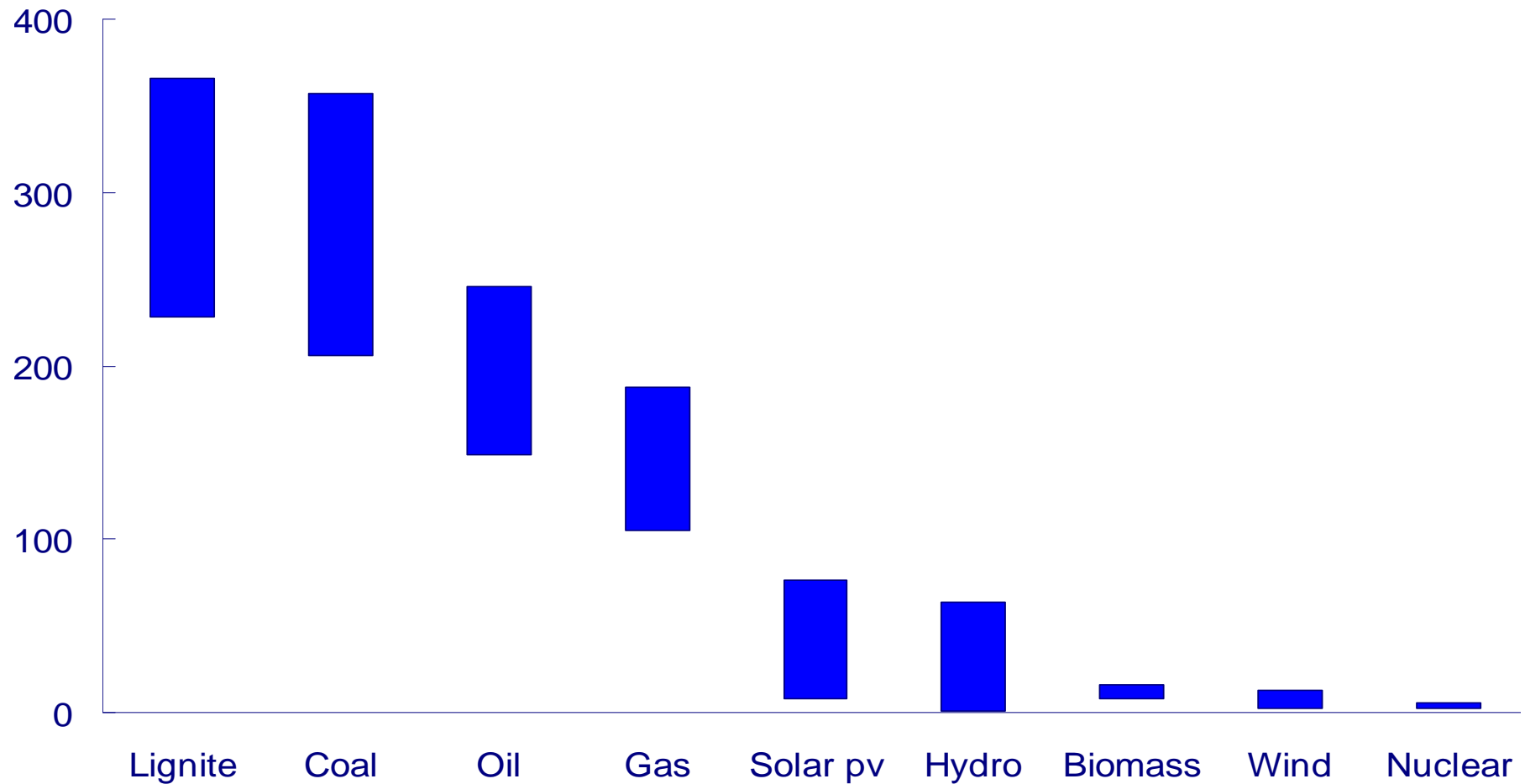

# Power Plant Land Use Required (km<sup>2</sup> / MW)

Source: J. Davidson (2000)

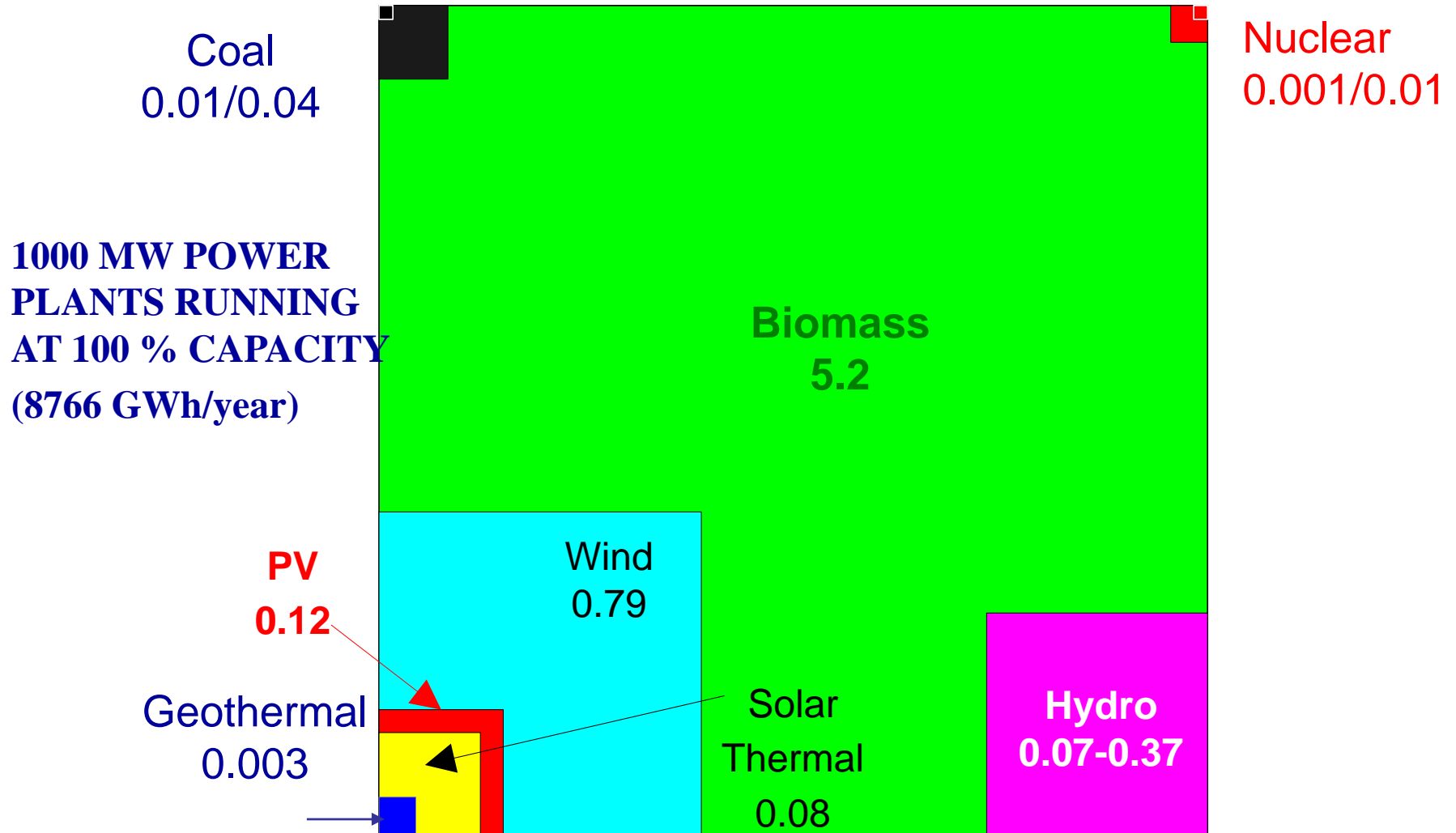

# Zauzeće zemljišta za elektranu od 1000 MWe

<b>Fossil and nuclear sites:</b>	<b>1–4 km<sup>2</sup></b>
<b>Solar thermal or photovoltaic (PV) parks: (a small city)</b>	<b>20–50 km<sup>2</sup></b>
<b><i>Wind fields:</i></b>	<b>50–150 km<sup>2</sup></b>
<b><i>Biomass plantations:</i></b>	<b>4000–6000 km<sup>2</sup></b>

# Materijali potrebni za gradnju

- Nuclear: 1970's vintage PWR, 90% capacity factor, 60 year life
  - –40 MT steel / MW(average)
  - –190 m<sup>3</sup> concrete / MW(average)
- Wind: 1990's vintage, 6.4 m/s average wind speed, 25% capacity factor, 15 year life
  - –460 MT steel / MW (average)
  - –870 m<sup>3</sup> concrete / MW(average)
- Coal: 78% capacity factor, 30 year life
  - –98 MT steel / MW(average)
  - –160 m<sup>3</sup> concrete / MW(average)
- Natural Gas Combined Cycle: 75% capacity factor, 30 year life
  - –3.3 MT steel / MW(average)
  - –27 m<sup>3</sup> concrete / MW(average)

**Concrete + steel are >95% of construction inputs**



# Osjetljivost cijene el. energije na promjenu cijene goriva

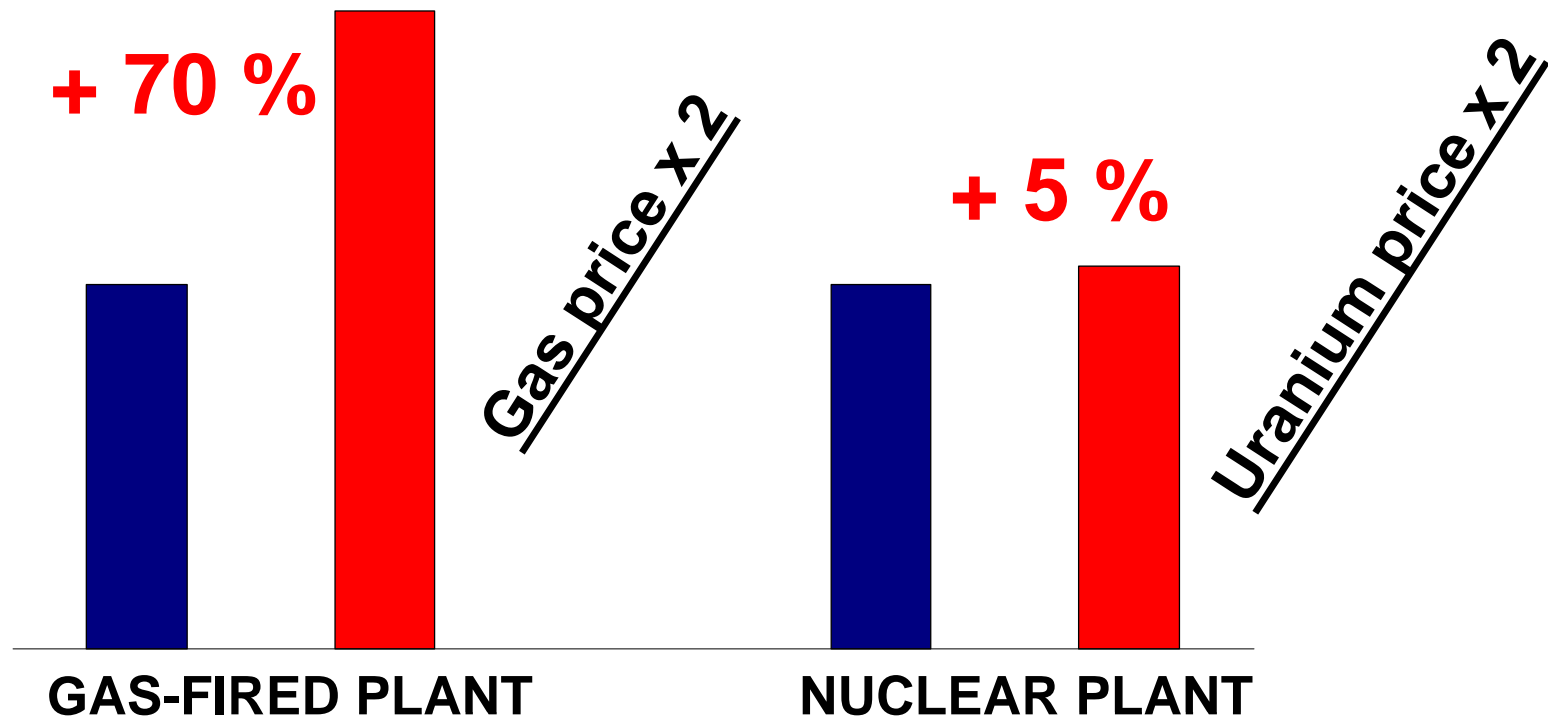

# Troškovi proizvodnje električne energije u SAD

## Operations, Maintenance and Fuel

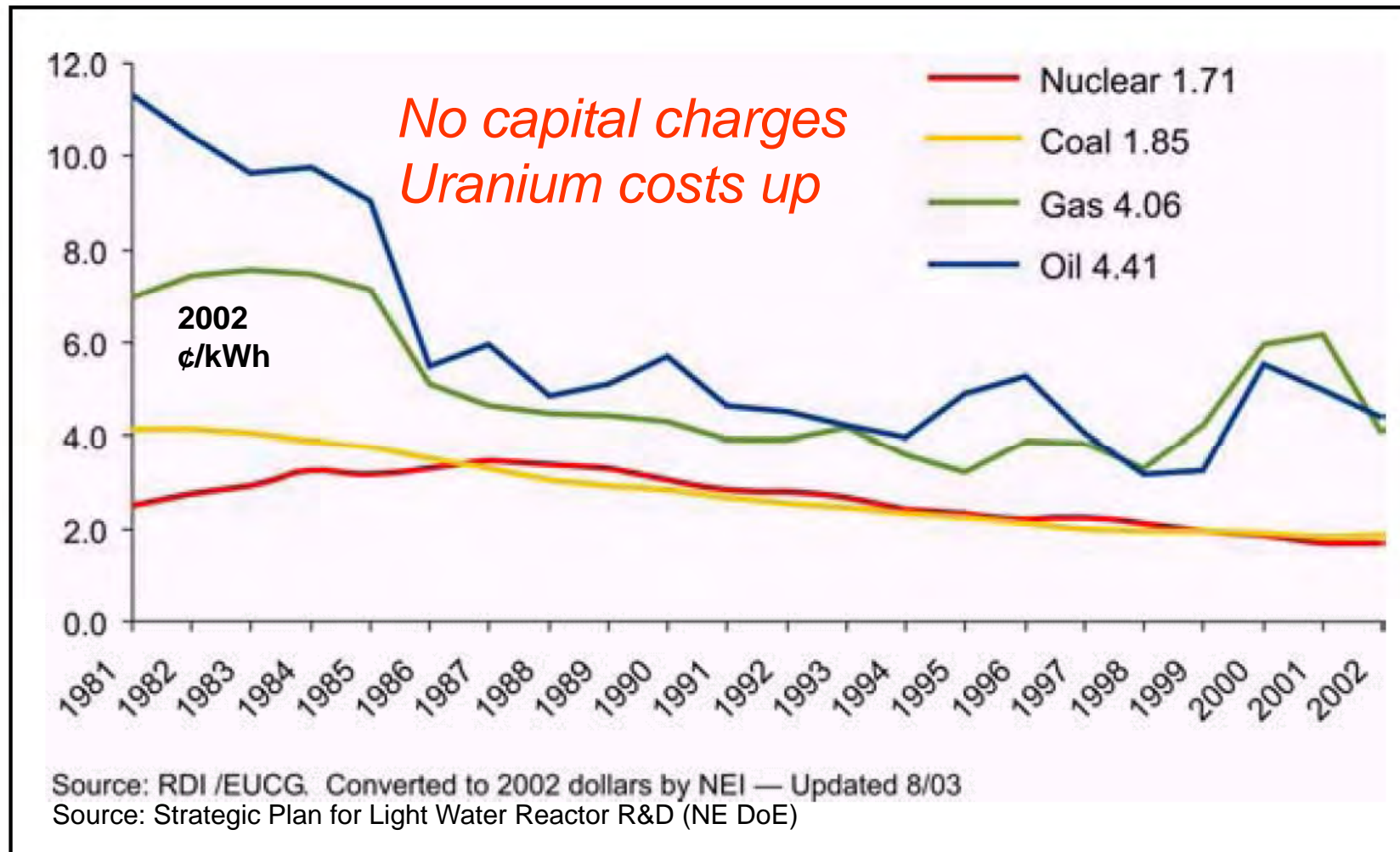

# Da li nuklearne elektrane imaju budućnost?

Da, ako nastave biti sigurne i pouzdane uz nisku proizvodnu cijenu električne energije i ako demonstriraju dugoročnu stabilnost za ulaganje i neovisna cijena goriva.

Za razliku od fosilnih tehnol  
za zaštitu okoliša, razgradnji  
su uzeti u obzir.

**Sigurnost i  
pouzdanost**

**Dugoročna  
stabilnost**

**Niska cijena**

**Povoljan utjecaj  
na okoliš**



# Nuklearni i klasični energetska izvori

## Deaths from Accidents from Generating Electricity per Billion MWe-hr

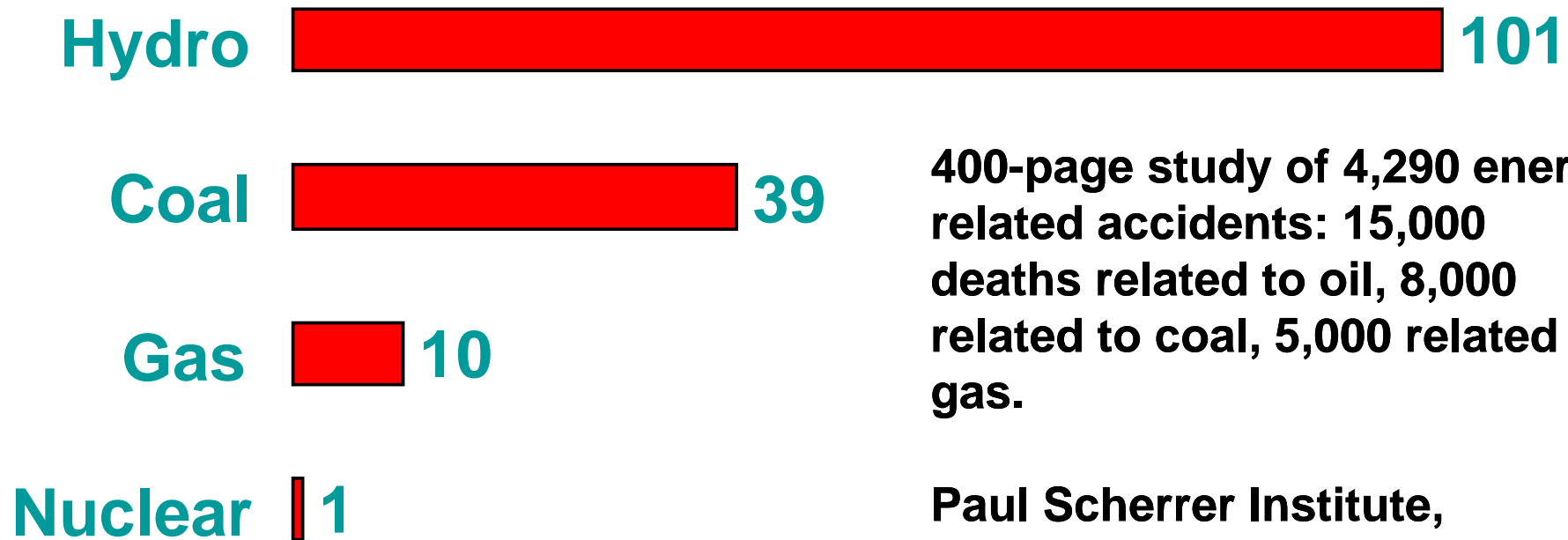

400-page study of 4,290 energy-related accidents: 15,000 deaths related to oil, 8,000 related to coal, 5,000 related to gas.

Paul Scherrer Institute, Switzerland, 2001

\*Includes Chernobyl

# Some energy-related accidents since 1977

<b>Place</b>	<b>year</b>	<b>number killed</b>	<b>comments</b>
Machhu II, India	1979	2500	hydro-electric dam failure
Hirakud, India	1980	1000	hydro-electric dam failure
Ortuella, Spain	1980	70	gas explosion
Donbass, Ukraine	1980	68	coal mine methane explosion
Israel	1982	89	gas explosion
Guavio, Colombia	1983	160	hydro-electric dam failure
Nile R, Egypt	1983	317	LPG explosion
Cubatao, Brazil	1984	508	oil fire
Mexico City	1984	498	LPG explosion
Tbilisi, Russia	1984	100	gas explosion
northern Taiwan	1984	314	3 coal mine accidents

# Some energy-related accidents since 1977

Chernobyl, Ukraine	1986	31+	nuclear reactor accident
Piper Alpha, North Sea	1988	167	explosion of offshore oil platform
Asha-ufa, Siberia	1989	600	LPG pipeline leak and fire
Dobrnja, Yugoslavia	1990	178	coal mine
Hongton, Shanxi, China	1991	147	coal mine
Belci, Romania	1991	116	hydro-electric dam failure
Kozlu, Turkey	1992	272	coal mine methane explosion
Cuenca, Ecuador	1993	200	coal mine
Durunkha, Egypt	1994	580	fuel depot hit by lightning
Seoul, S.Korea	1994	500	oil fire
Minanao, Philippines	1994	90	coal mine
Dhanbad, India	1995	70	coal mine

# Some energy-related accidents since 1977

Taegu, S.Korea	1995	100	oil & gas explosion
Spitsbergen, Russia	1996	141	coal mine
Henan, China	1996	84	coal mine methane explosion
Datong, China	1996	114	coal mine methane explosion
Henan, China	1997	89	coal mine methane explosion
Fushun, China	1997	68	coal mine methane explosion
Kuzbass, Siberia	1997	67	coal mine methane explosion
Huainan, China	1997	89	coal mine methane explosion
Huainan, China	1997	45	coal mine methane explosion
Guizhou, China	1997	43	coal mine methane explosion
Donbass, Ukraine	1998	63	coal mine methane explosion
Liaoning, China	1998	71	coal mine methane explosion

# Some energy-related accidents since 1977

Warri, Nigeria	1998	500+	oil pipeline leak and fire
Donbass, Ukraine	1999	50+	coal mine methane explosion
Donbass, Ukraine	2000	80	coal mine methane explosion
Shanxi, China	2000	40	coal mine methane explosion
Guizhou, China	2000	150	coal mine methane explosion
Shanxi, China	2001	38	coal mine methane explosion
Sichuan, China	2002	23	coal mine methane explosion
Jixi, China	2002	115	coal mine methane explosion



## Comparison of accident statistics in primary energy production

Fuel	Immediate fatalities 1970-92	Who?	Deaths per TWy* electricity
Coal	6400	workers	342
Natural gas	1200	workers & public	85
Hydro	4000	public	883
Nuclear	31	workers	8

Electricity generation accounts for about 40% of total primary energy

# Energija iz fosilnih goriva

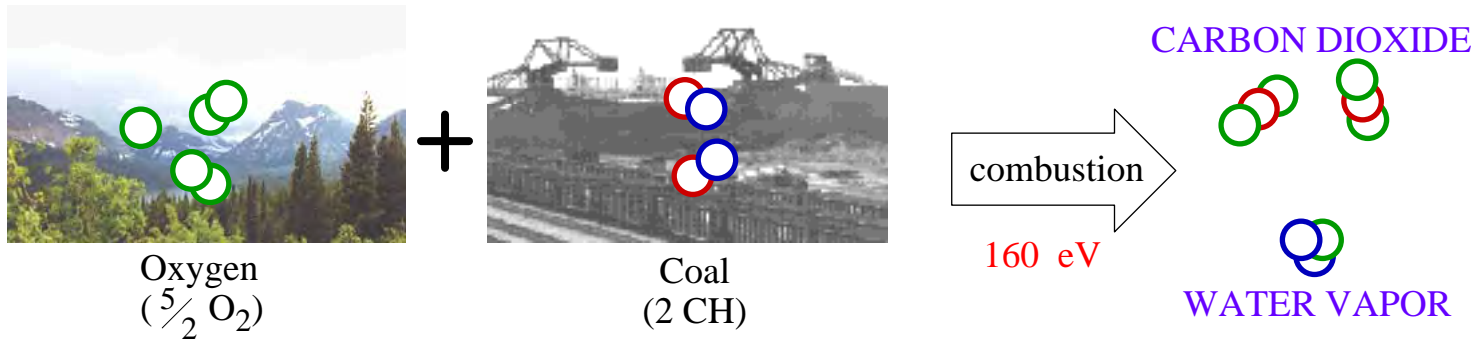

- **Fossil Fuel (Coal) Energy Density:**  $2.9 \times 10^7 \text{ J/kg}$
- **Fuel Consumed by 1000-MW<sub>e</sub> Plant:** 7,300,000 kg/day
- **Waste:**

<u>Coal Combustion Products</u>		<u>Mining</u>
NO <sub>x</sub>	→ High temperature combustion	Leachates/ dust from mining
SO <sub>x</sub>	→ Sulfur in coal (0.4% - 5%)	
Ash	→ (5% - 25% of coal mass)	Construction materials
CO <sub>2</sub>	→ Global warming	

1999 Global Coal Consumption: 3 billion tons

# Energija nuklearne fisije

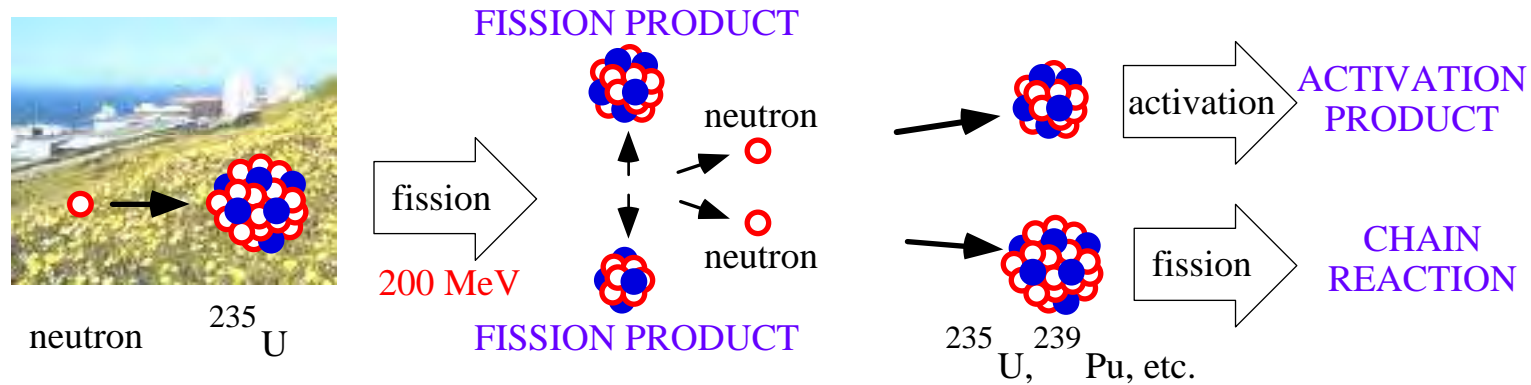

- **Fission Fuel Energy Density:**  $8.2 \times 10^{13} \text{ J/kg}$  (20,000  $t_{\text{HE}}/\text{kg}$ )
- **Fuel Consumed by 1000-MW<sub>e</sub> Plant:** 3.2 kg/day
- **Waste:**

## Fission Prod. (3.2 kg/day)

$^{90}\text{Sr}$ , 30 yr;  $^{137}\text{Cs}$ , 30 yr;  
 $^{99}\text{Tc}$ ,  $2 \times 10^5$  yr; etc.

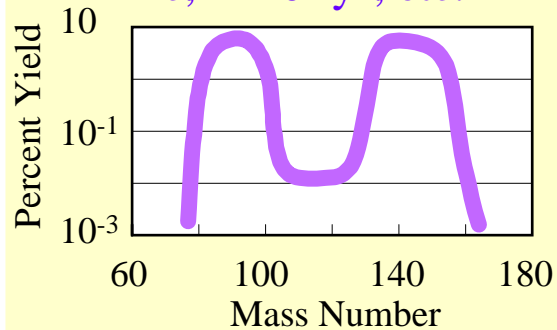

## Activation Products

Fuel → Transuranics, longer half lives ( $^{239}\text{Pu}$ , 24,000 yr;  $^{237}\text{Np}$ ,  $2 \times 10^6$  yr; etc.)

Structures → Moderate half lives, low-level waste ( $^{60}\text{Co}$ , 5 yr)

Coolants → Low (water) to moderate (metals) half lives

Transmutation → Convert from long to short half life

## Mining

Radon from mill tails if not capped

Construction materials

# Energija nuklearne fuzije

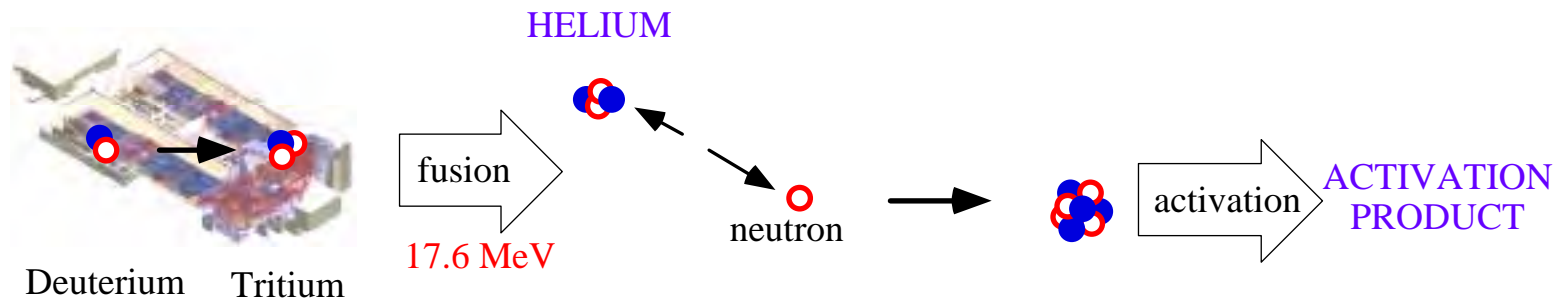

- **Fusion Fuel Energy Density:**  $3.4 \times 10^{14}$  J/kg
- **Fuel Consumed by 1000-MW<sub>e</sub> Plant:** 0.6 kg/day
- **Waste:**

## Activation Products

Structures → Moderate half lives, depends strongly on material selection (low atomic mass better)

Coolants → Short half lives (low atomic mass)

Blanket →  $n + {}^6\text{Li} \rightarrow 4\text{He} + \text{T}$   
 $n + {}^m\text{M} \rightarrow 2n + {}^{m-1}\text{M}$

## Mining

Construction materials

# Energija iz atomske jezgre

## *Fuzija*

Spajanje manjih jezgri u veću

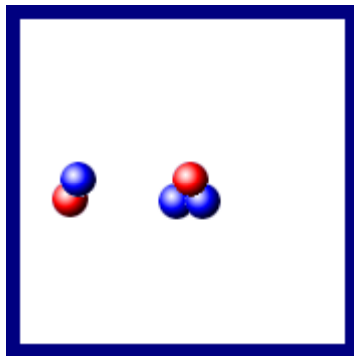

## *Fisija*

Raspad teških jezgri na lakše

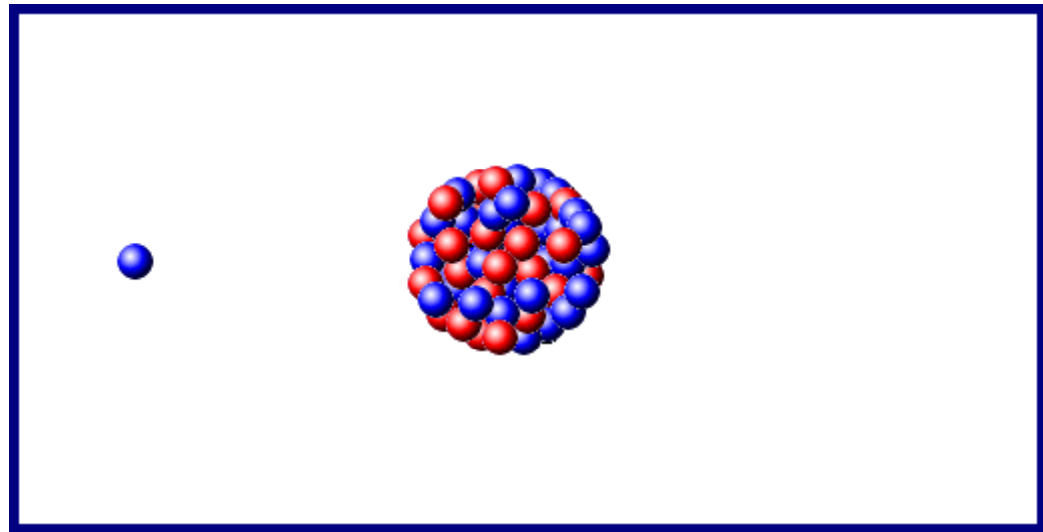

# Fisija Urana

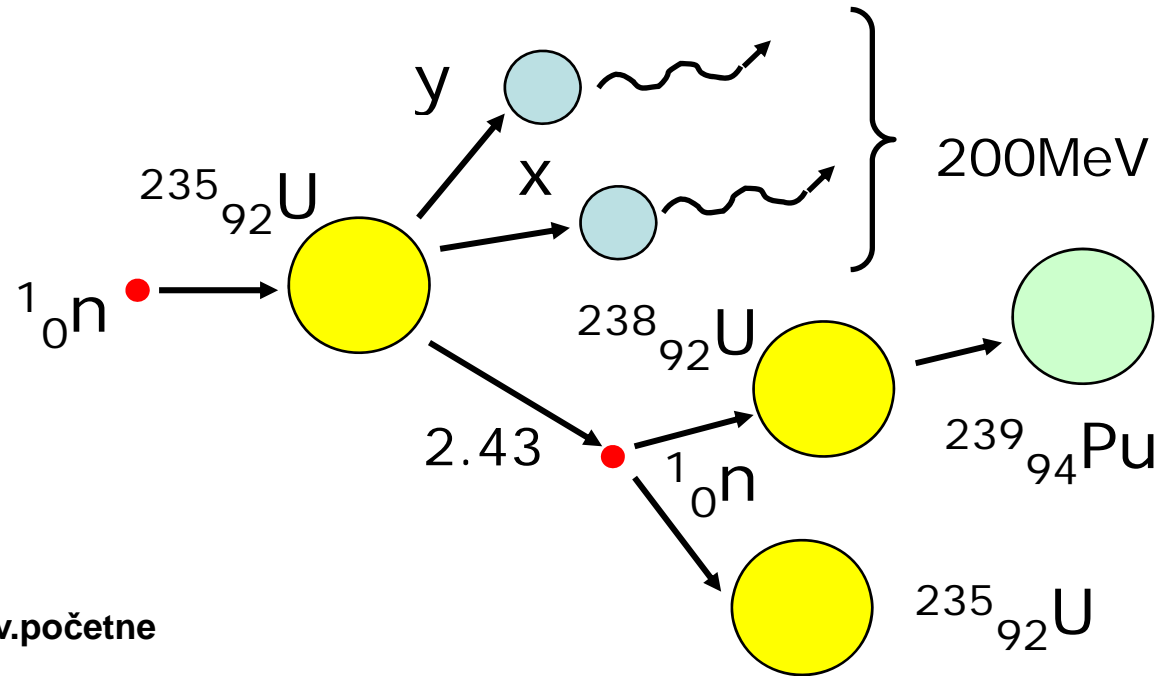

Fisija:  $\Delta E_{\text{vezanja}} > E_{\text{aktivacije}}$

$$\Delta E_{\text{vezanja.jezgre}} = E_{\text{v.nastale}} - E_{\text{v.početne}}$$

$E_{\text{aktivacije}}$  = potrebna energija za fisiju

U235 – fisibilan

U238 – fisibilan s pragom

$$1 \text{ eV} = 1,60219\text{E-}19 \text{ J}$$

$$200 \text{ Mev} = 3,204\text{E-}11 \text{ J}$$

$$1 \text{ W} = 3,124\text{E}10 \text{ fisija}$$

Sustained reaction

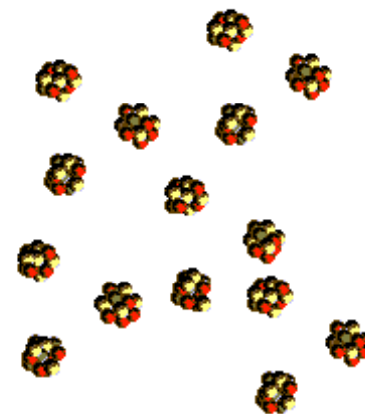

Energija iz fisije	
Kinetička fragmenata	83.5%
Trenutne $\gamma$ -zrake	2.5%
Kinetička neutrona	2.5%
$\beta$ -raspad fragmenata	3.5%
$\gamma$ zrake fragmenata	3.0%
Energija neutrina	5.0%

# Nuklearni reaktor

- Nuklearni reaktor je sustav projektiran da omogući kontroliranu samoodržavajuću nuklearnu reakciju fisije
- Parametar koji opisuje tijek odvijanja procesa naziva se multiplikacijski faktor  $k$ .
- Definiran je kao omjer srednjeg broja neutrona u dvije susjedne generacije neutrona (prije i poslije fisije)
- Da bi se nuklearna reakcija mogla nadzirati njegova vrijednost ne smije biti puno veća od 1
- Reaktor koji ima  $k=1$  zovemo kritičnim reaktorom i on održava konstantan broj neutrona i snagu proizvedenu fisijom
- Ako je  $k<1$  broj neutrona i snaga reaktora će se s vremenom smanjivati i reaktor zovemo podkritičnim a ako je  $k>1$  broj neutrona u reaktoru i snaga reaktora će se povećavati i reaktor zovemo nadkritičnim
- Kako je  $k$  u praksi vrlo blizu 1 uvedena je veličina koja se naziva reaktivnost i definirana je kao  $\rho=(k-1)/k$  i predstavlja relativno odstupanje reaktora od kritičnog stanja

# Ciklus neutrona u reaktoru

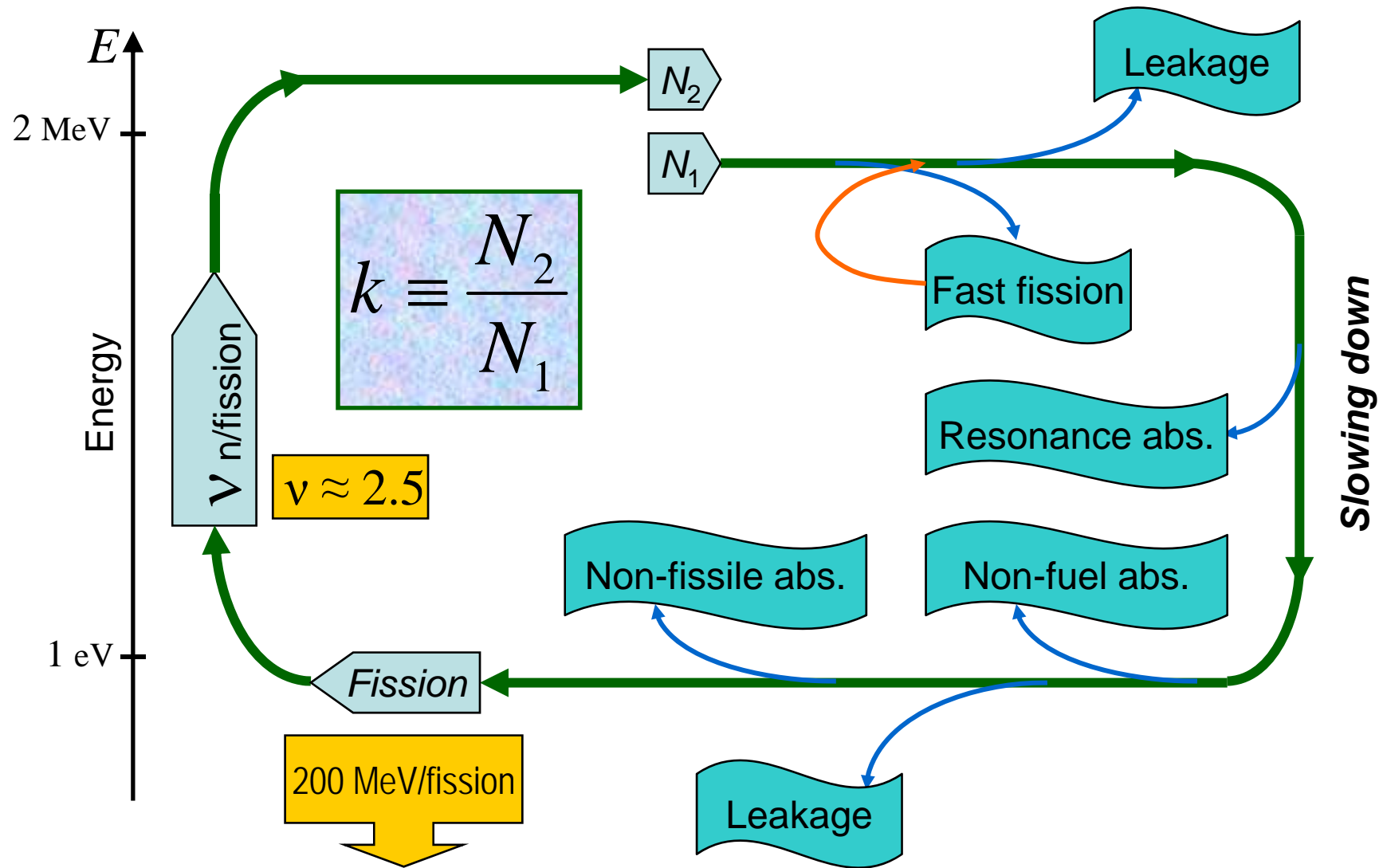



# Ciklus neutrona u reaktoru

- Neutroni su unutar reaktora podvrgnuti procesu difuzije (struje od mjesta veće gustoće prema mjestu niže gustoće)
- Za kritičnost reaktora bitne su dvije vrste neutrona
- Promptni neutroni nastaju direktno pri fisiji
- Zakašnjeli neutroni su rezultata raspada fisijskih produkata
- Udjel zakašnjelih neutrona u ukupnom broju neutrona je od 0.22% do 0.65%
- Najveći broj zakašnjelih neutrona se pojavi unutar 70 s nakon procesa fisije
- Zakašnjeli neutroni su bitni za kontrolu reaktora

# Osnovni izgled reaktora

- Nuklearno gorivo je organizirano u gorivne elemente
- Moderator je materijal koji ima sposobnost usporavanja neutrona
- Rashladno sredstvo odvodi toplinu iz reaktora
- Posebni kontrolni elementi napravljeni od materijala koji absorbiraju neutrone služe za nadzor broja neutrona raspoloživih za fisiju
- Nuklearno gorivo, moderator, rashladno sredstvo i kontrolni element čine jezgru reaktora
- Jezgra je okružena štitom od zračenja

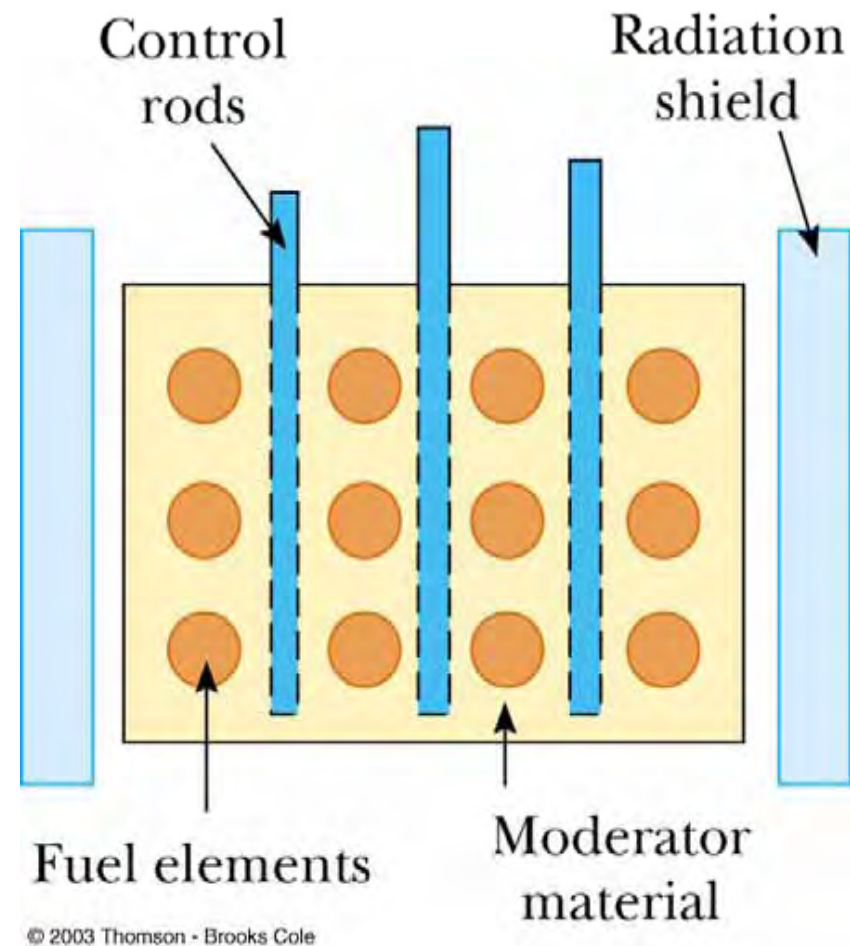

# Tipovi reaktora

- **Reaktori se mogu podijeliti:**
  - prema tipu goriva
  - korištenom hladiocu (rashladnom sredstvu)
  - potrebi za usporavanje neutrona
    - brzi reaktori
    - termički reaktori (tip moderatora)
  - namjeni reaktora
    - istraživački reaktori,
    - proizvodnja električne energije i/ili topline,
    - proizvodnja nuklearnog materijala
    - proizvodnja vodika
    - desalinizacija
- **Da se osigura lančana reakcija potrebno je:**
  - imati odgovarajuću količinu goriva
  - ograničiti apsorpciju neutrona
  - ograničiti bijeg neutrona (kritične dimenzije reaktora i reflektor)

# Ostatna toplina

Generirana snaga  
nakon obustave reaktora:

- ostatna toplina posljedica je radioaktivnog raspada fisijskih produkata

$P_0$  – snaga reaktora prije obustave

$t_0$  – vrijeme rada reaktora

$t$  – vrijeme rada i obustave

(vremena su u danima)

$$P = P_0 \cdot 0,0061 \cdot \left[ (t - t_0)^{-0,2} - t^{-0,2} \right]$$

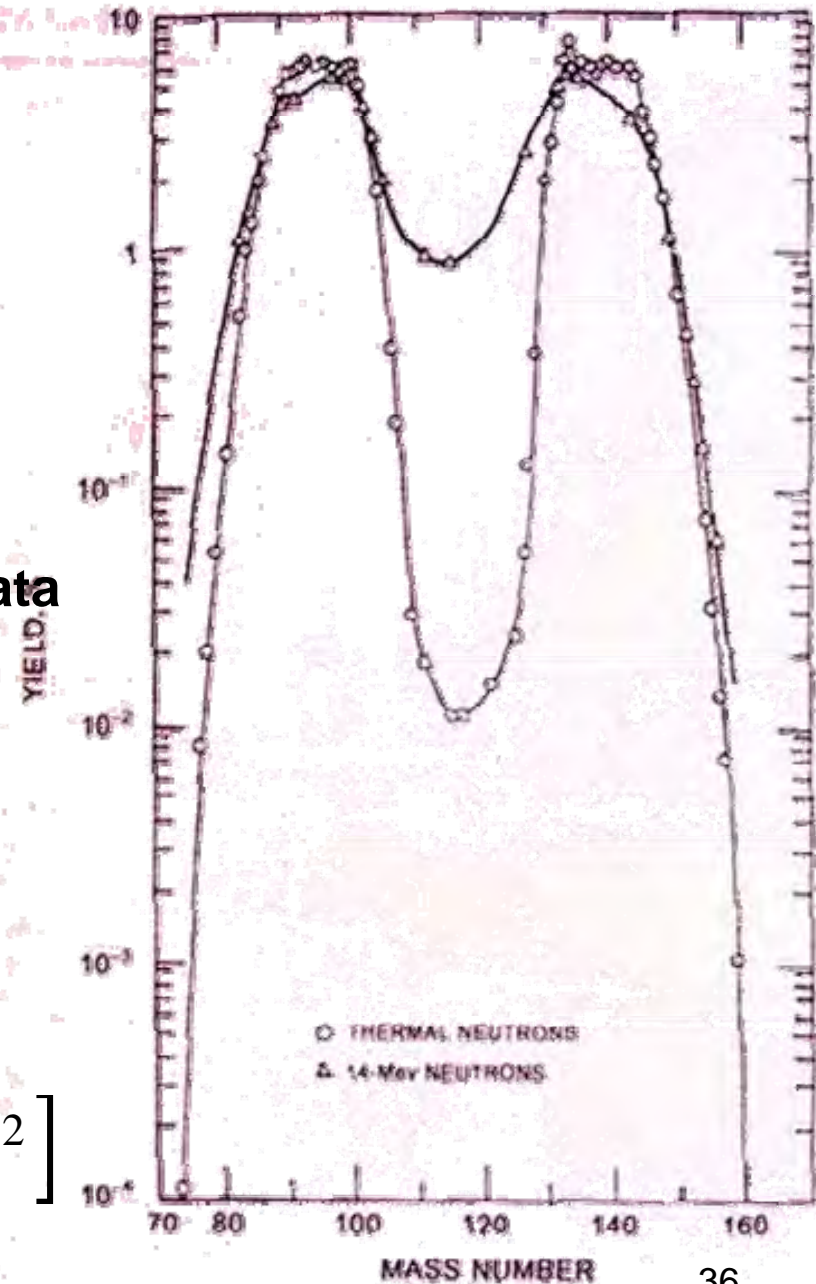

# Ostatna toplina

- Fisijom nastaju nova jezgra – fisijski fragmenti
- Postoji stotinjak načina na koji se teška jezgra može cijepati
- Novonastala jezgra su beta i gama radioaktivna jer imaju višak neutrona obzirom na broj protona  $Z$
- Približno 180 MeV energije se oslobodi neposredno pri fisiji a oko 20 je posljedica radioaktivnog raspada fisijskih produkata
- Brzina osobađanja te zakašnjele energije ovisi o konstantama radioaktivnog raspada
- Radioaktivnost fisijskih produkata i pripadajuća toplina osnovni su sigurnosni problem u reaktoru
- Zaustavljanjem lančane reaktivnost ovaj izvor ne nestaje
- Neposredno nakon obustave ostatna toplina iznosi približno 6% nominalne snage na kojoj je reaktor radio
- Zbog velikog broja fisijskih produkata iznos ostatne topline uzimamo u obzir aproksimativnim relacijama

# Fisijski produkti

- plemeniti plinovi: Kr, Xe
- lako hlapljivi FP: I, Cs, Te ...
- srednje hlapljivi FP: Ba, La, Sr, Ru ...
- slabo hlapljivi FP: aktinidi, In, Cd ...

Ispuštanje FP u 2 faze:

1. "gap release": ispuštanje plinovitih FP iz zazora nakon pucanja košuljice
2. nakon topljenja goriva ispuštaju se preostali plinoviti FP i lako hlapljivi FP

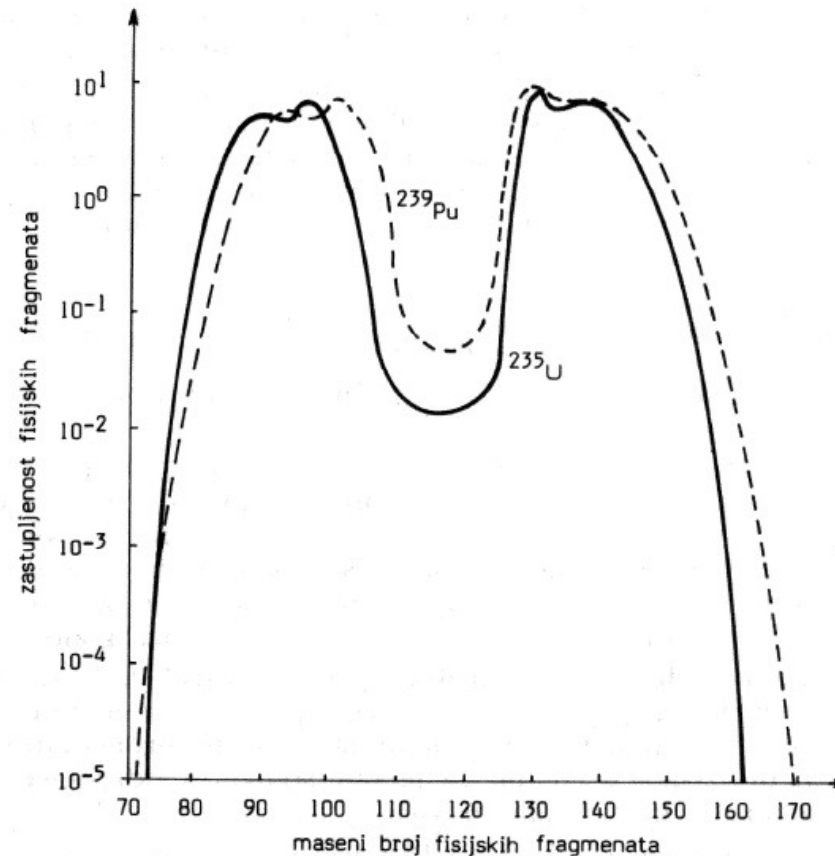

# Fisijski produkti

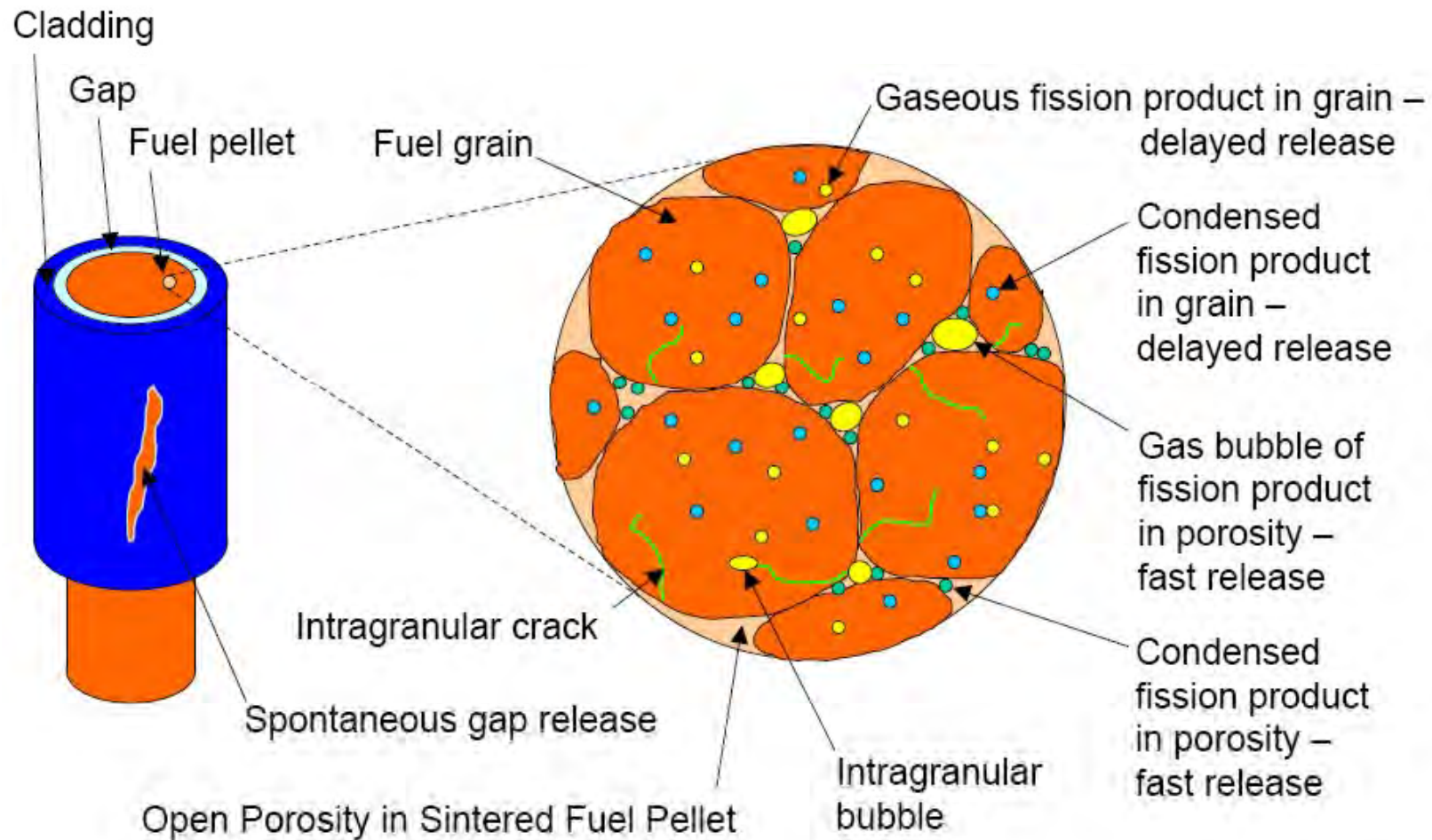



# NE PWR – princip rada

## Tipični parametri PWR-a:

- primarni tlak 15 do 16 MPa
  - prosječna primarna temp. 570-590 K
  - porast temp. u reaktoru 40 do 50 K
  - protok po rashl. krugu 6 m<sup>3</sup>/s (oko 4500 kg/s)
- sekundarni tlak 6 do 8 MPa  
temperatura pojne vode 490 K  
protok pare po parogeneratoru 520 kg/s

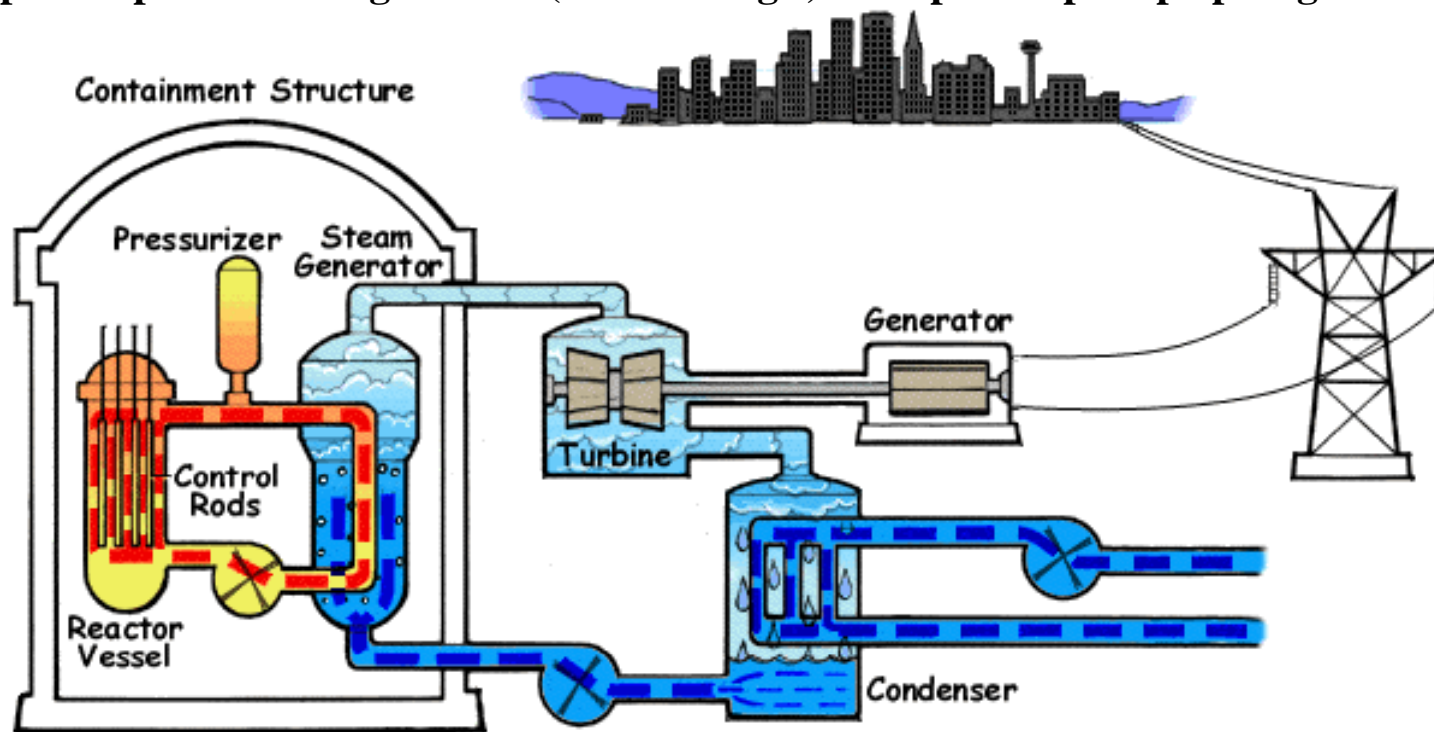



# Gorivni element i gorivna šipka

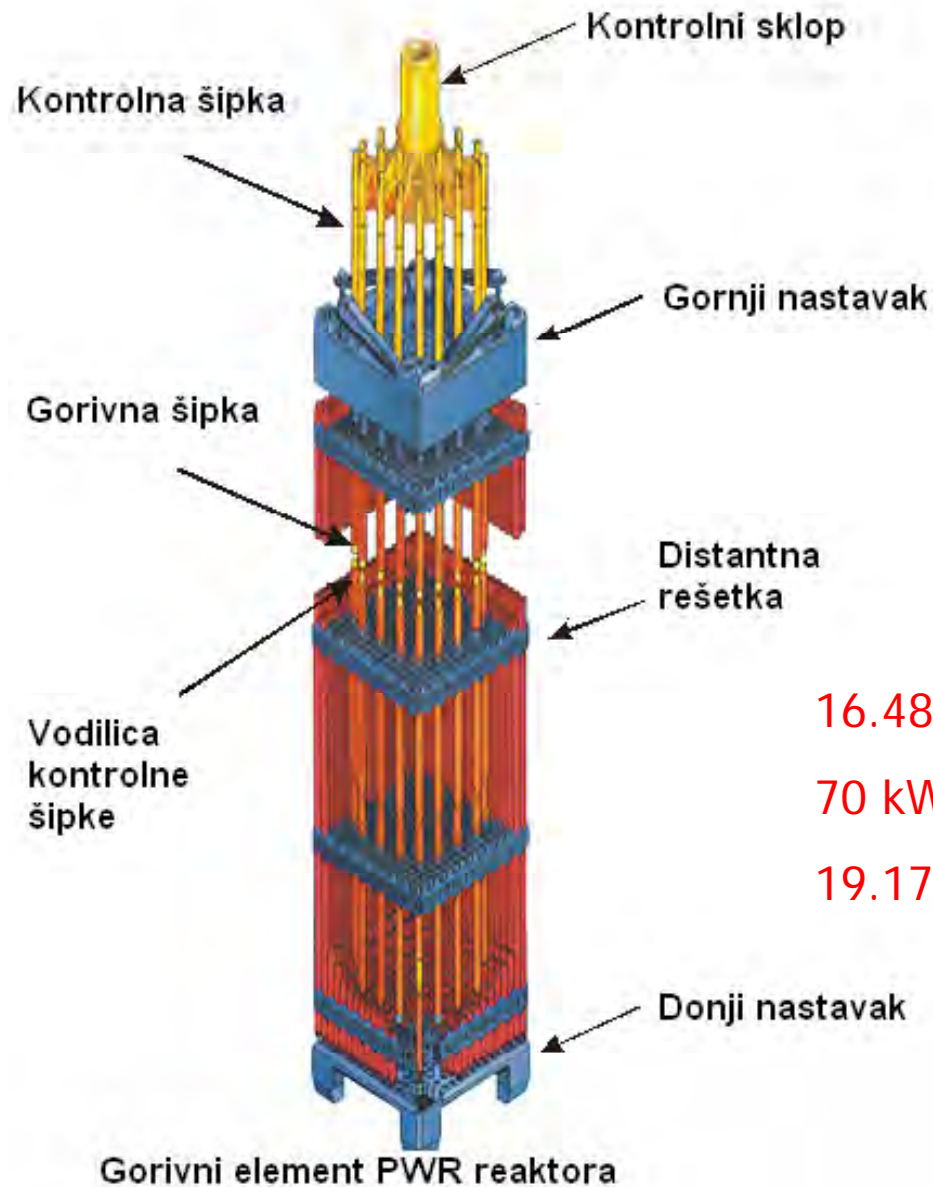

16.48 MW/FA

70 kW/šipka

19.17 kW/m

Gorivna šipka PWR reaktora

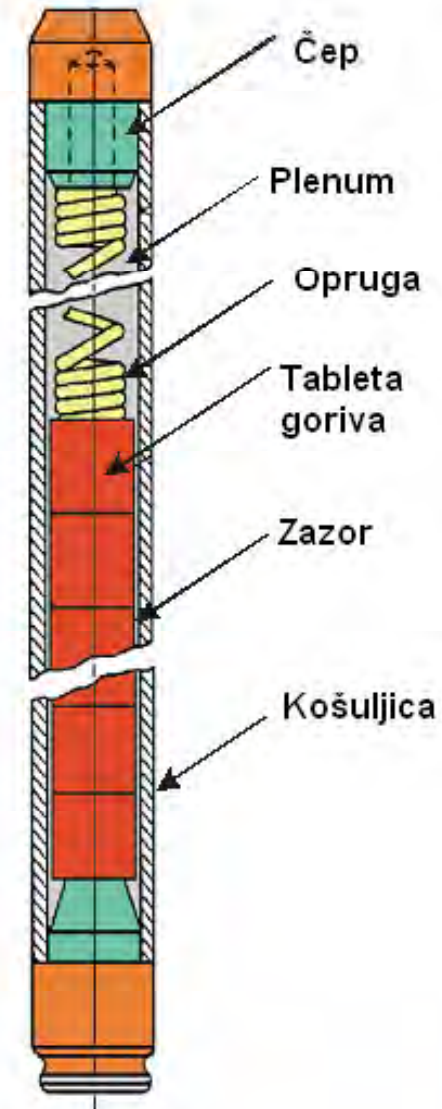

# Sigurnost nuklearnih elektrana

- Zanemarive emisije u normalnom pogonu
- Konzervativan projekt s visokim stupnjem sigurnosti
- Visoki zahtjevi na kvalitetu materijala i ugradnju
- Da bi se postigao siguran pogon potrebno je:
  - *spriječiti nagle poraste snage*
  - *osigurati odvođenje ostatne topline*
  - *spriječiti ispuštanje radioaktivnog materijala*
  - *pospremiti na siguran način istrošeno gorivo*

# **Principi sigurnosnih mjera u nuklearnim elektranama**

- **Nuklearna eksplozija reaktora je onemogućena projektom**
- **U svojoj jezgri nuklearni reaktor sadrži veliku količinu radioaktivnih tvari, pretežno fizijskih proizvoda.**
- **Sigurnost se u osnovi odnosi na onemogućenje širenja radioaktivnih materijala unutar postrojenja i u okoliš**
- **Do akcidentnog ispuštanja uglavnom dolazi samo ako dođe do pregrijanja goriva**
- **Sigurnost nuklearne elektrane se postiže nizom mjera u fazi projektiranja, gradnje i tijekom pogona.**

# Da li je nuklearna elektrana tempirana nuklearna bomba?



Nuklearna eksplozija nije moguća za obogaćenje i sastav jezgre u reaktoru

Ali je potrebno spriječiti i ograničiti promptne poraste snage

# Odvođenje topline

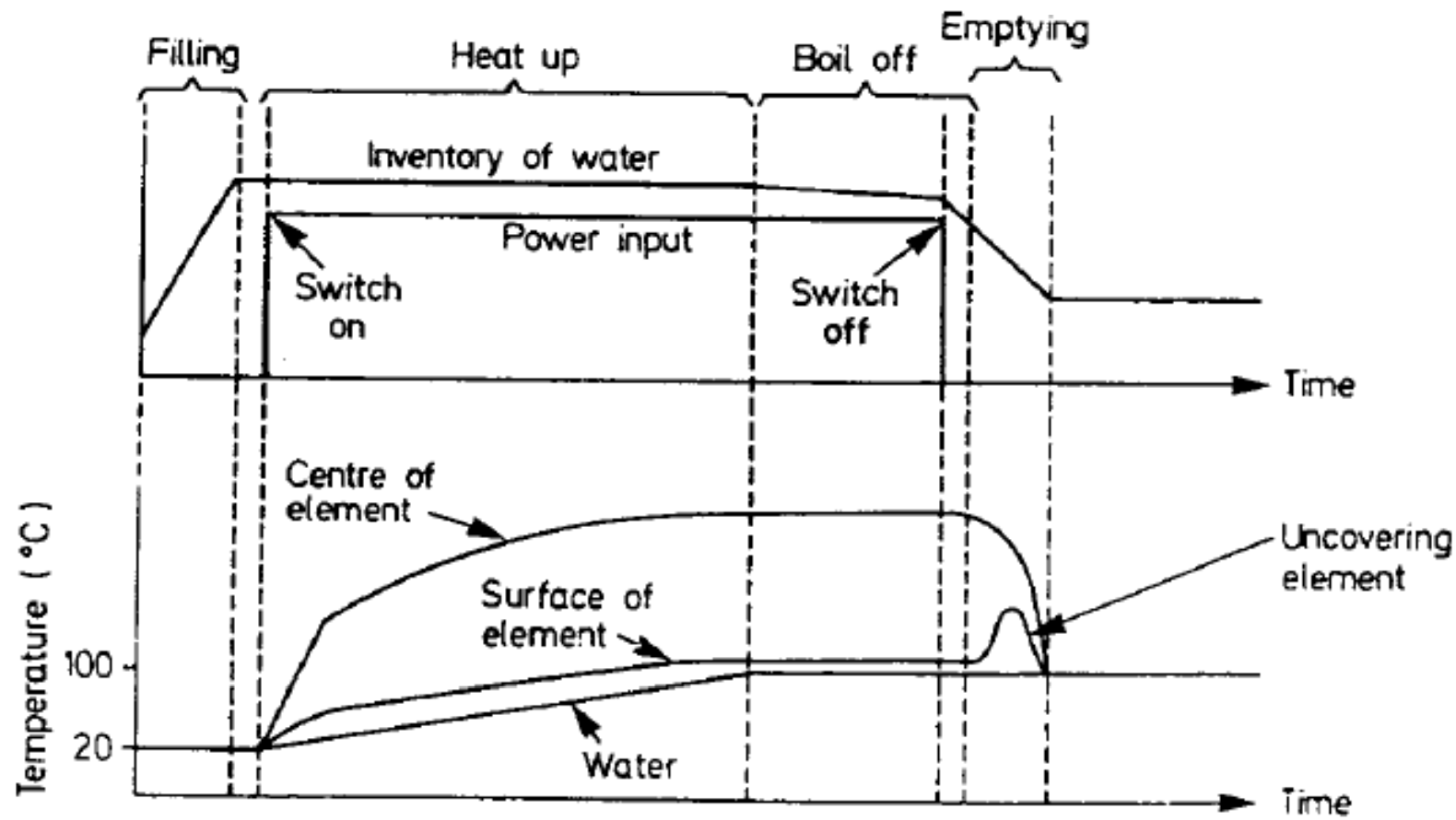
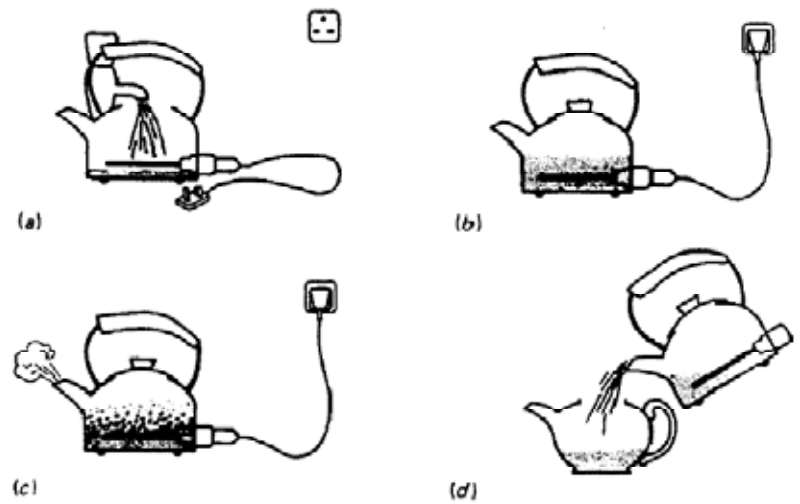



# Kineski sindrom – da li je moguć?

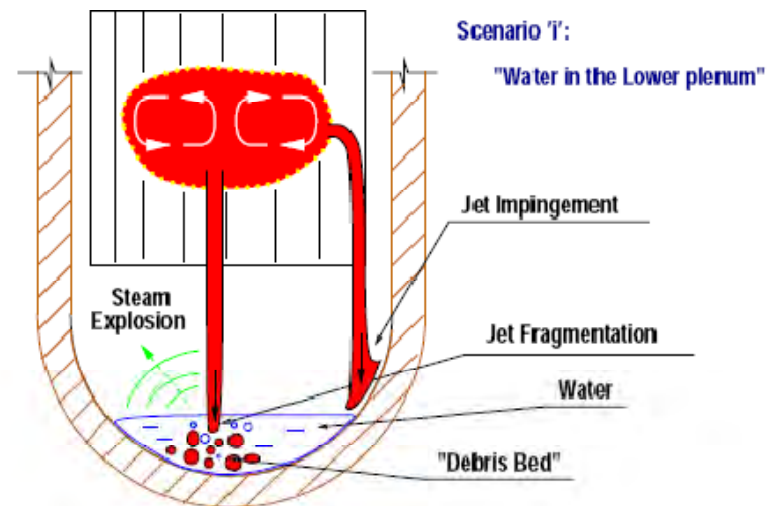
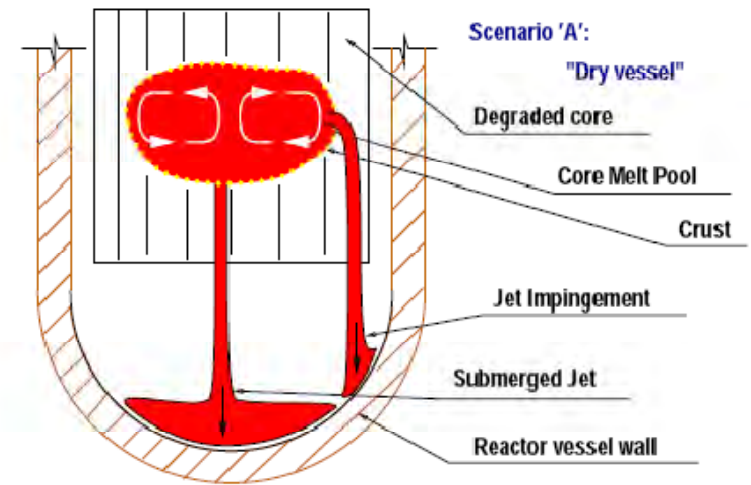
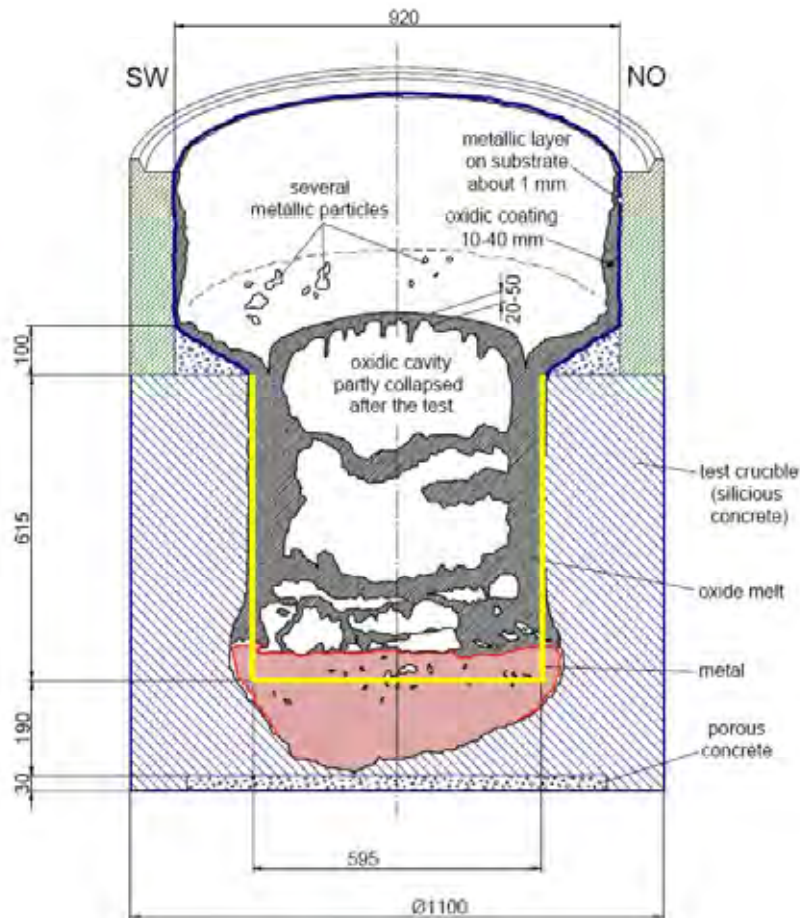
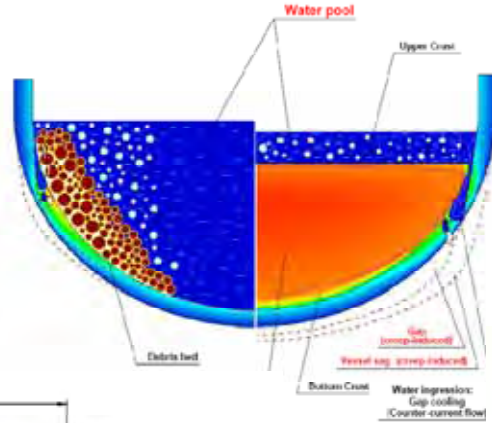

# Porast temperature jezgre obustavljen reaktor bez hlađenja

- Ostatna toplina 30 MW.
- 100,000 kg materijala u jezgri.
- Pretpostavljena srednja specifična toplina materijala jezgre 600 J/kg-C.
- Porast temperature C/s.
- Nakon 30 min srednja temperatura jezgre bi porasla 900 C.

# Kritične sigurnosne funkcije

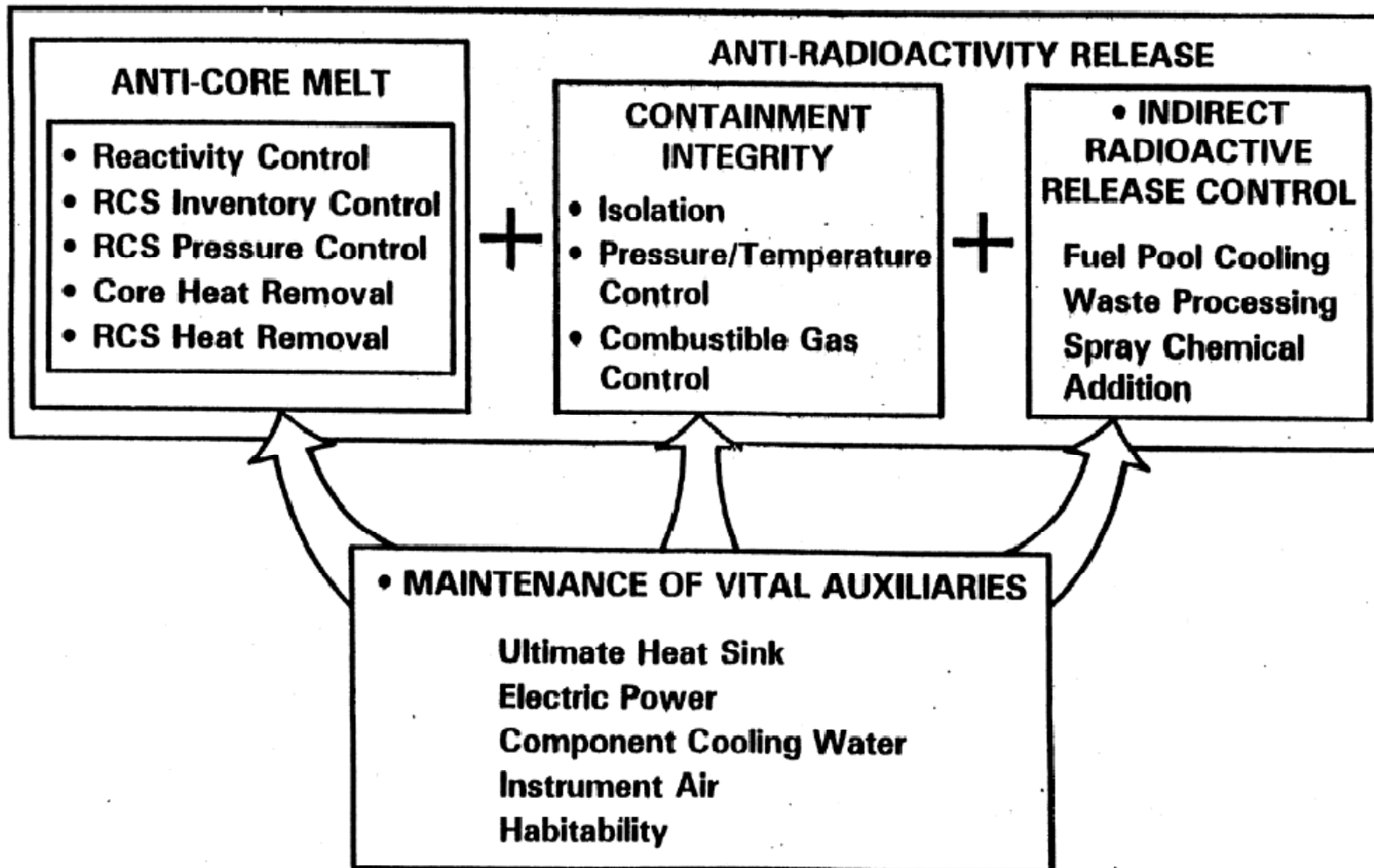



# Obrana po dubini

- Osnova filozofije projektiranja nuklearne elektrane sa stajališta sigurnosti je tzv. obrana po dubini.
- Obrana po dubini pretpostavlja postojanje višestrukih barijera za širenje radioaktivnosti i sigurnosnih sustava koji osiguravaju njihovu nepropusnost
- Barijere u smislu zaštite okoliša djeluju serijski, jedna nakon druge.
- Izgublenu funkciju jednog sustava važnog za sigurnost automatski preuzima drugi.
- Bitni sustavi su u najmanju ruku udvojeni
- Sustavi mogu biti aktivni ili pasivni (kako dobivaju energiju potrebnu za izvršavanje sigurnosne funkcije)
- Barijere možemo razmatrati kao stvarne fizičke barijere ugrađene u nuklearnu elektranu i kao fizičke i administrativne mjere koje se poduzimaju u nuklearnoj elektrani za zaštitu tih barijera.

# Obrana po dubini

- **Fizičke barijere su:**
  - matrica nuklearnog goriva
  - obloga gorivnog elementa
  - primarni rashladni krug
  - zaštitna posuda (kontejnment)
  
- **Tehnički sustavi koji osiguravanju funkciju fizičkih barijera:**
  - sustav za zaštitno hlađenje jezgre reaktora (štiti gorivne elemente od pregrijanja)
  - sustav za ograničavanje porasta tlaka u kontejnmentu (štiti zaštitnu posudu od previsokog tlaka i temperature)

# Višeslojna zaštita

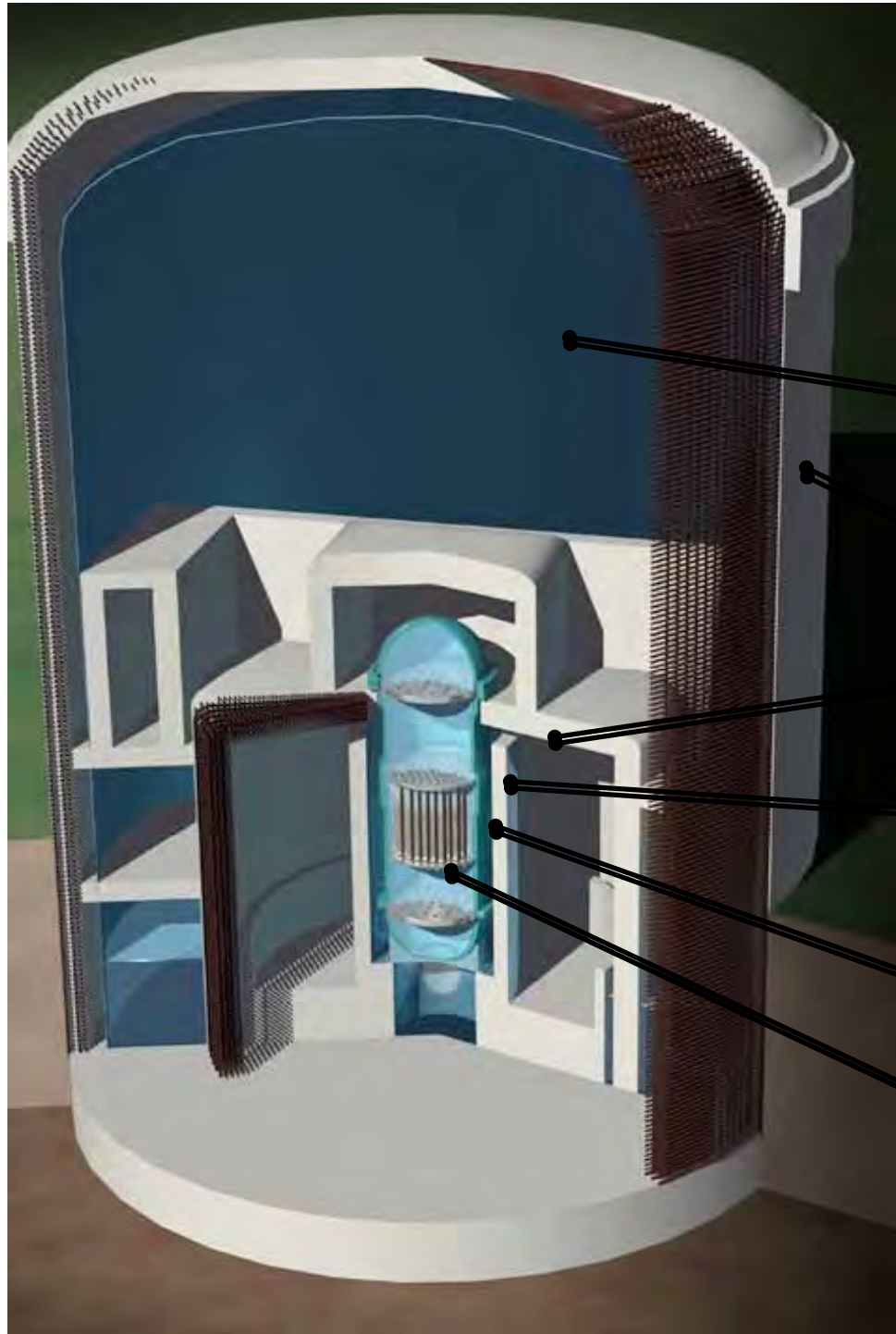

Kontejnmentska posuda  
4 cm čelika

Kontejnmentska zgrada  
1 m prenapregnutog betona

Unutrašnja betonska struktura  
1.5 m prenapregnutog betona

Biološki štit  
1,2 m teškog betona +  
4 cm čelika

Reaktorska posuda  
20 cm čelika

Matrica goriva + košuljica

# Prostorni aspekt obrane po dubini

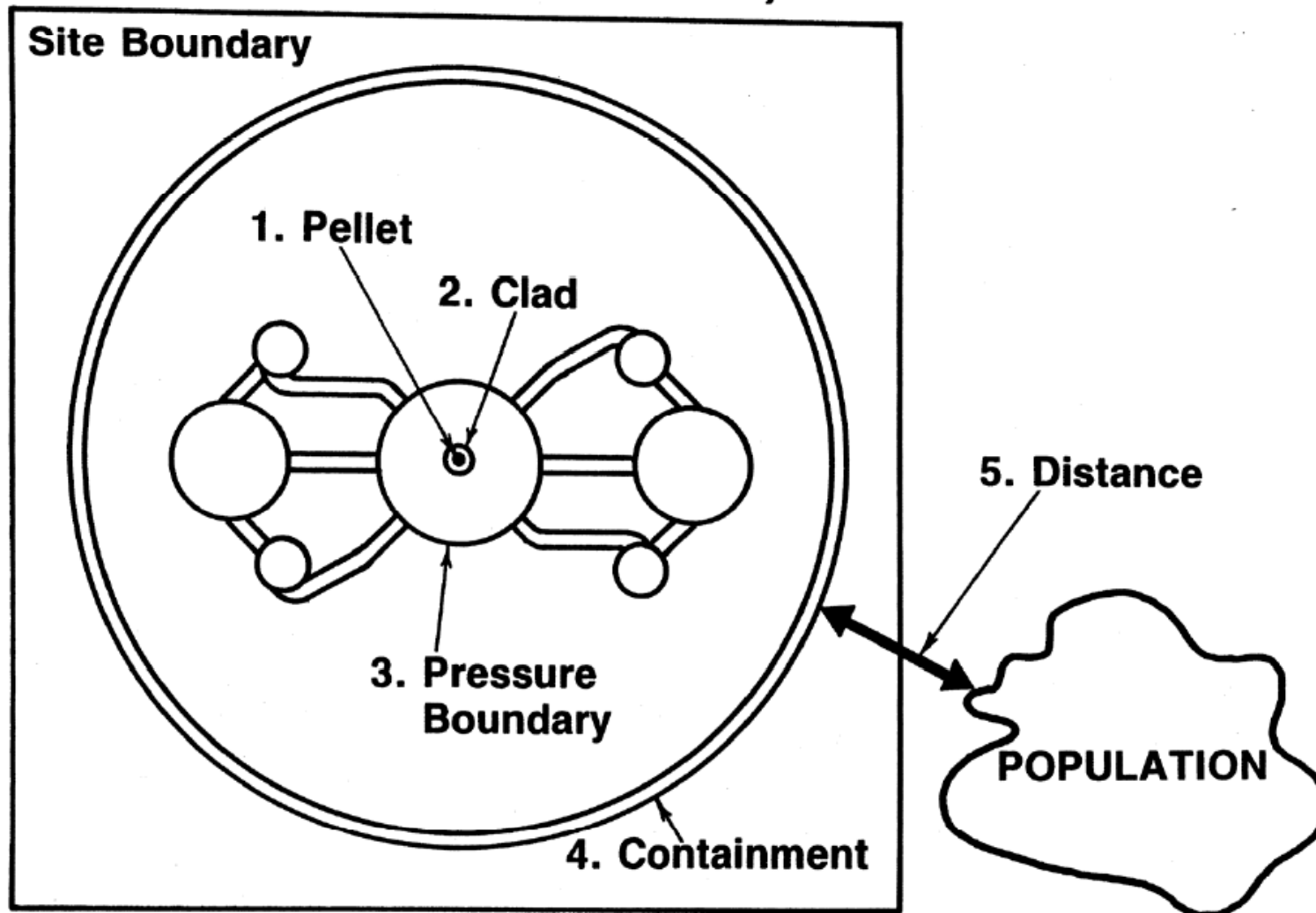

# Lociranje elektrane

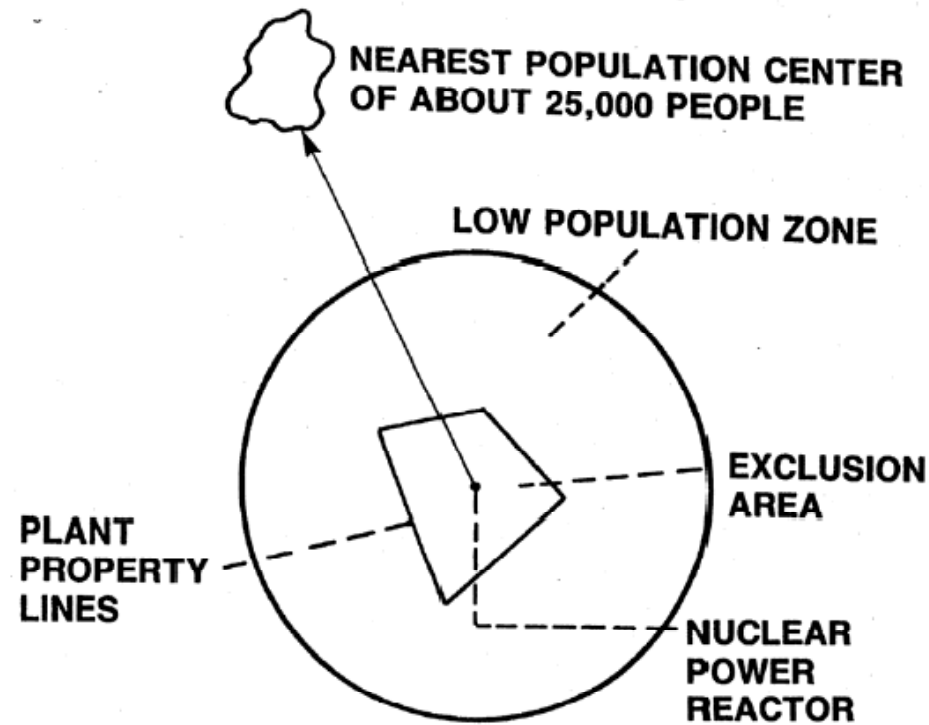

- At Boundary of Exclusion Area, No Member of Public May Exceed 25 rem Whole-Body Dose for Design Basis Accident
- Timely Evacuation of Low Population Zone Must be Planned
- Population Center Must Be at Least 1-1/3 Times Farther Away than LPZ Boundary

# Ponašanje efluenata oslobođenih u atmosferu

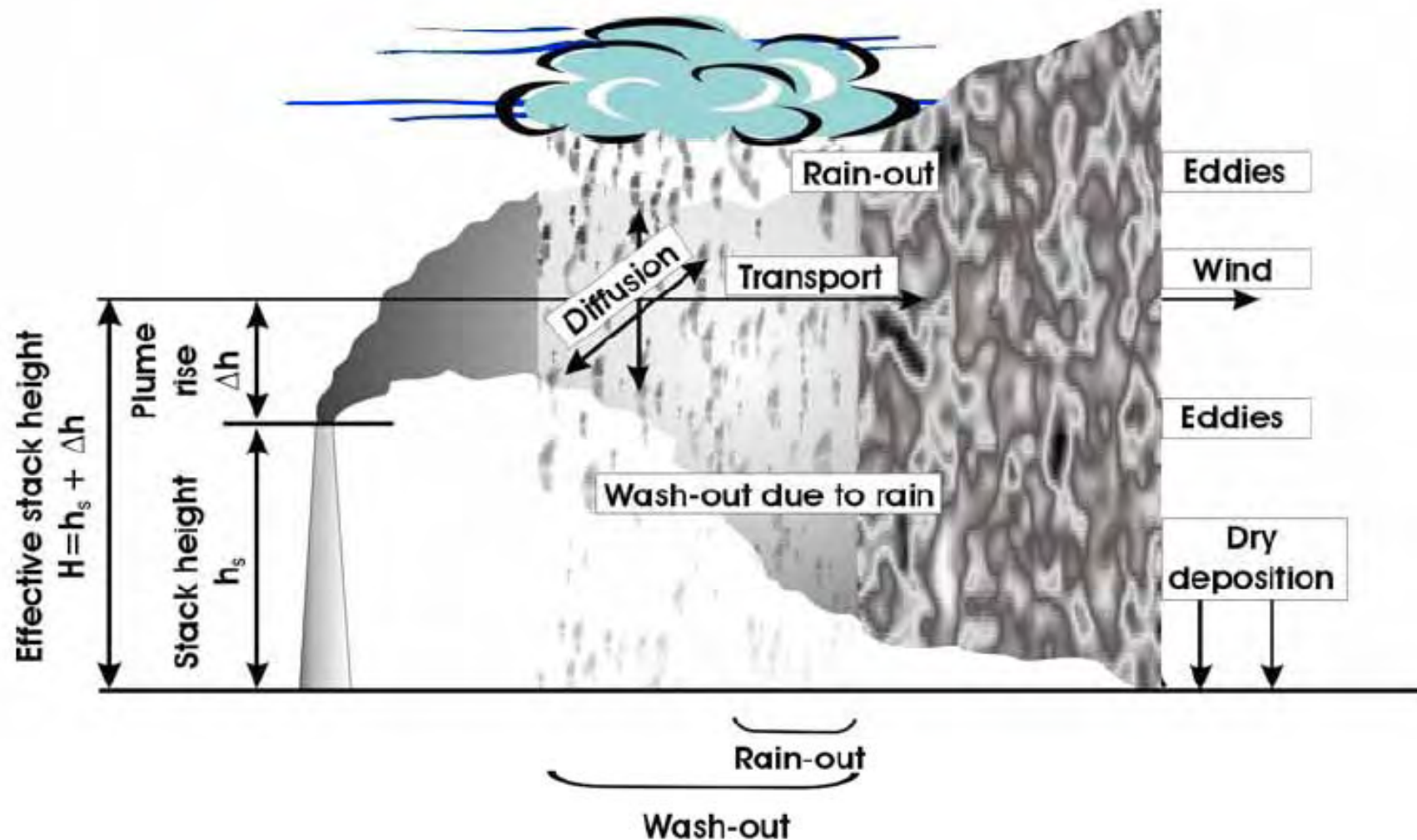

# Planovi u slučaju nuklearne nesreće

## Planning



## Preferential action

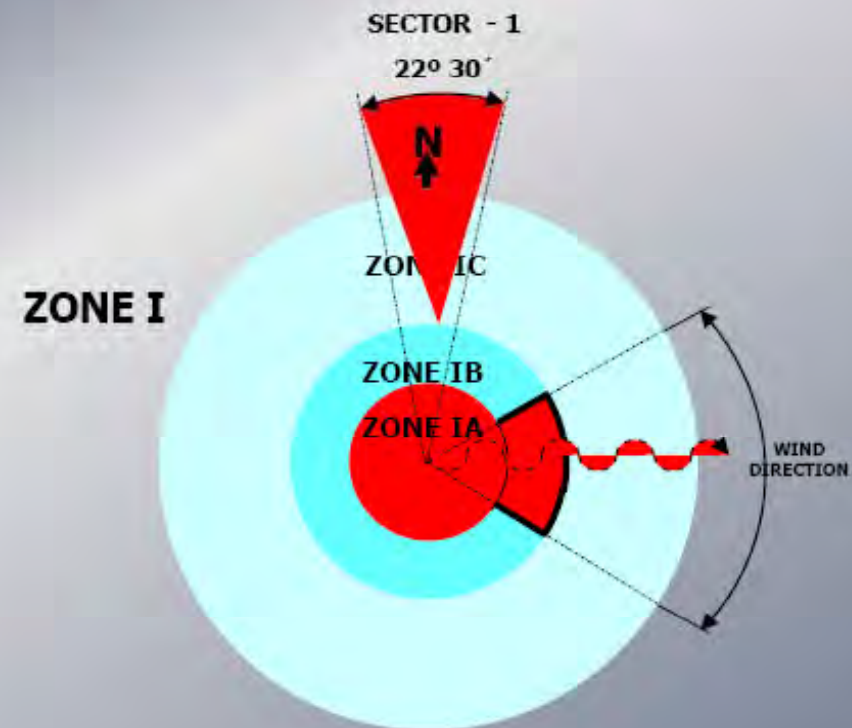

# Ideja obrane po dubini

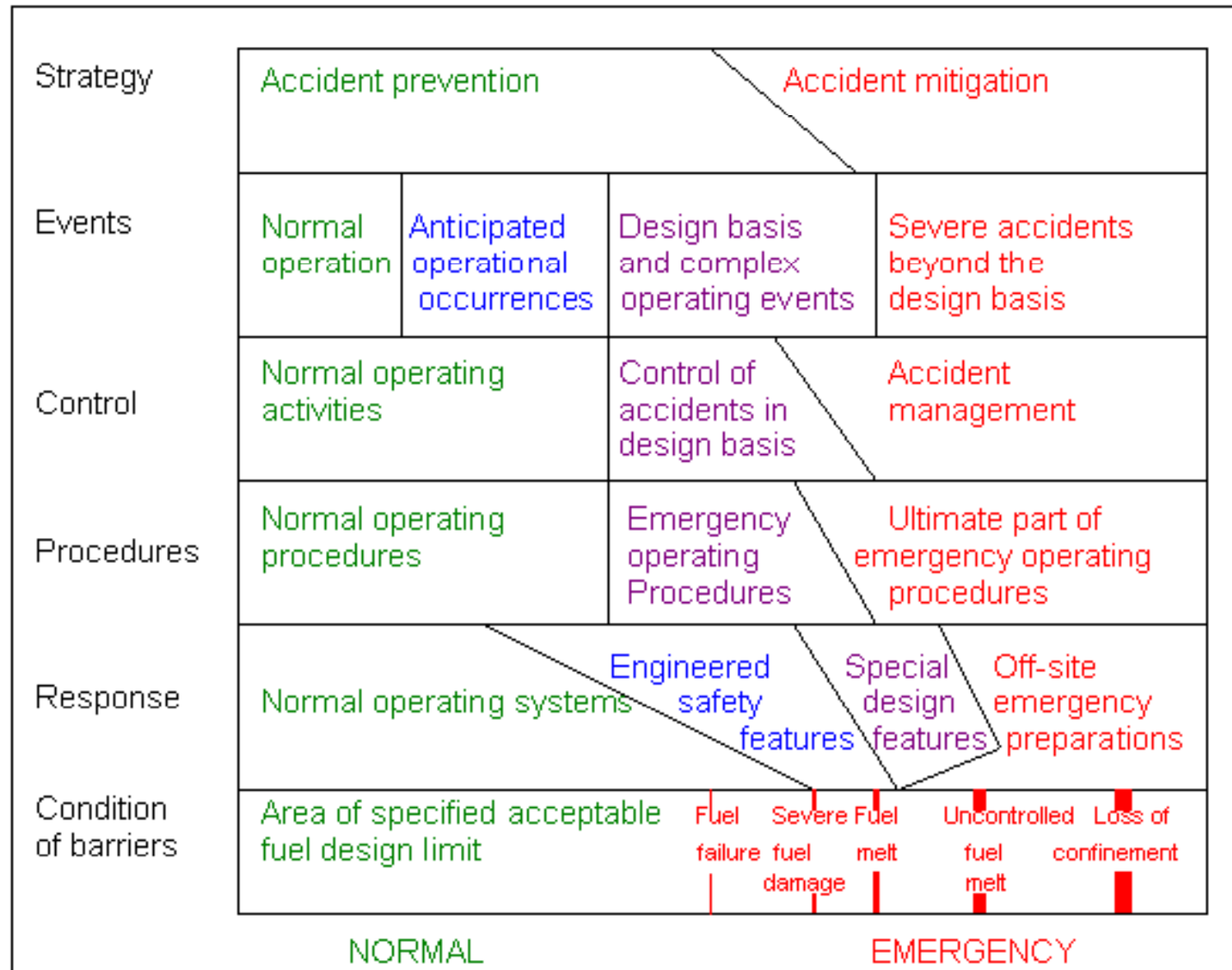



# Relacija između fizičkih barijera i nivoa obrane po dubini

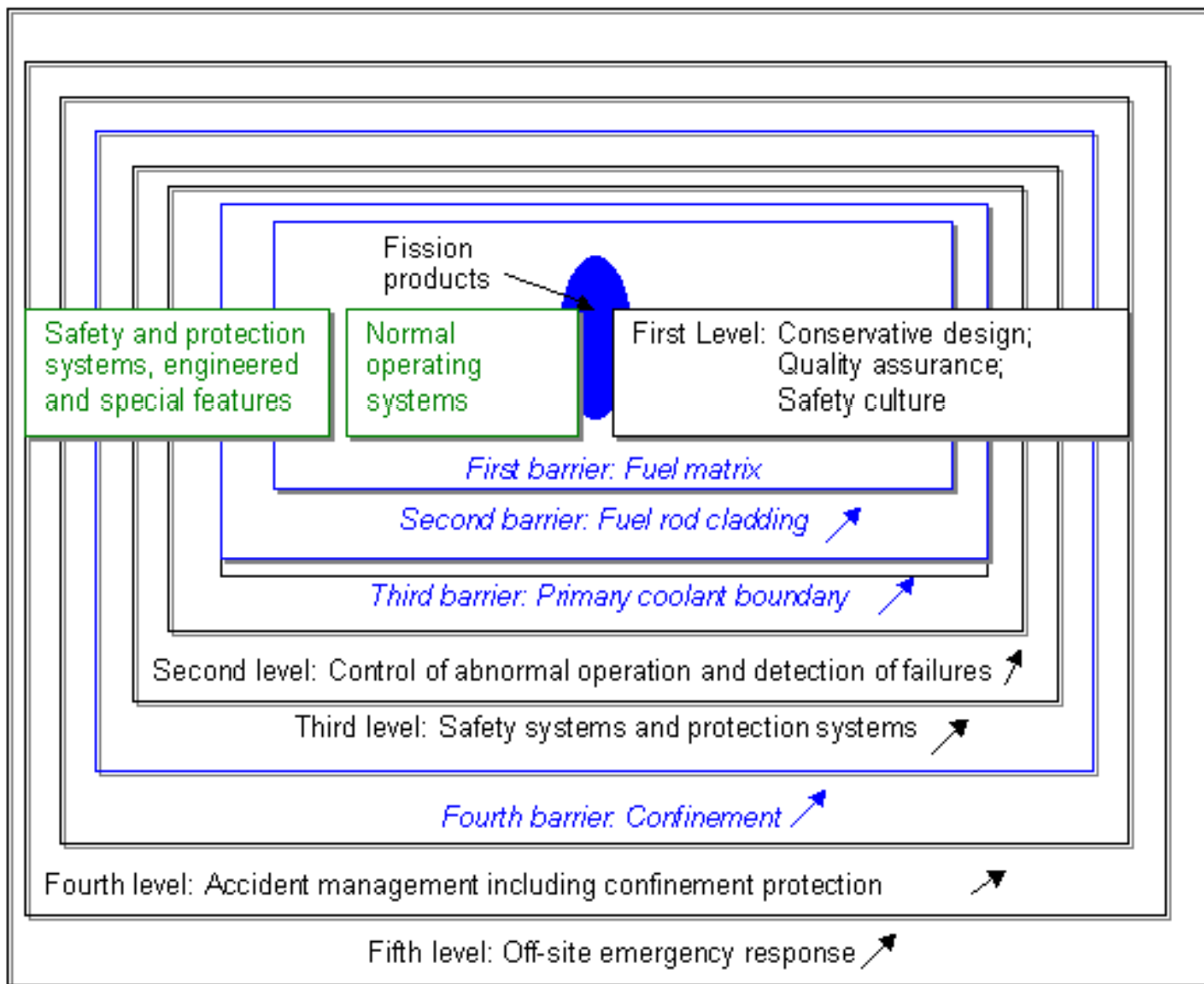

# Principi projektiranja sigurnosnih sustava

- Jednostruki otkaz
- Redundantnost
- Diverzitet
- Neovisnost sustava
- Fizička separacija
- Sigurni smjer greške
- Provjera stanja sustava
- Aktivna i pasivna sigurnost

# Pasivni sigurnosni sustavi

## Primjer AP1000

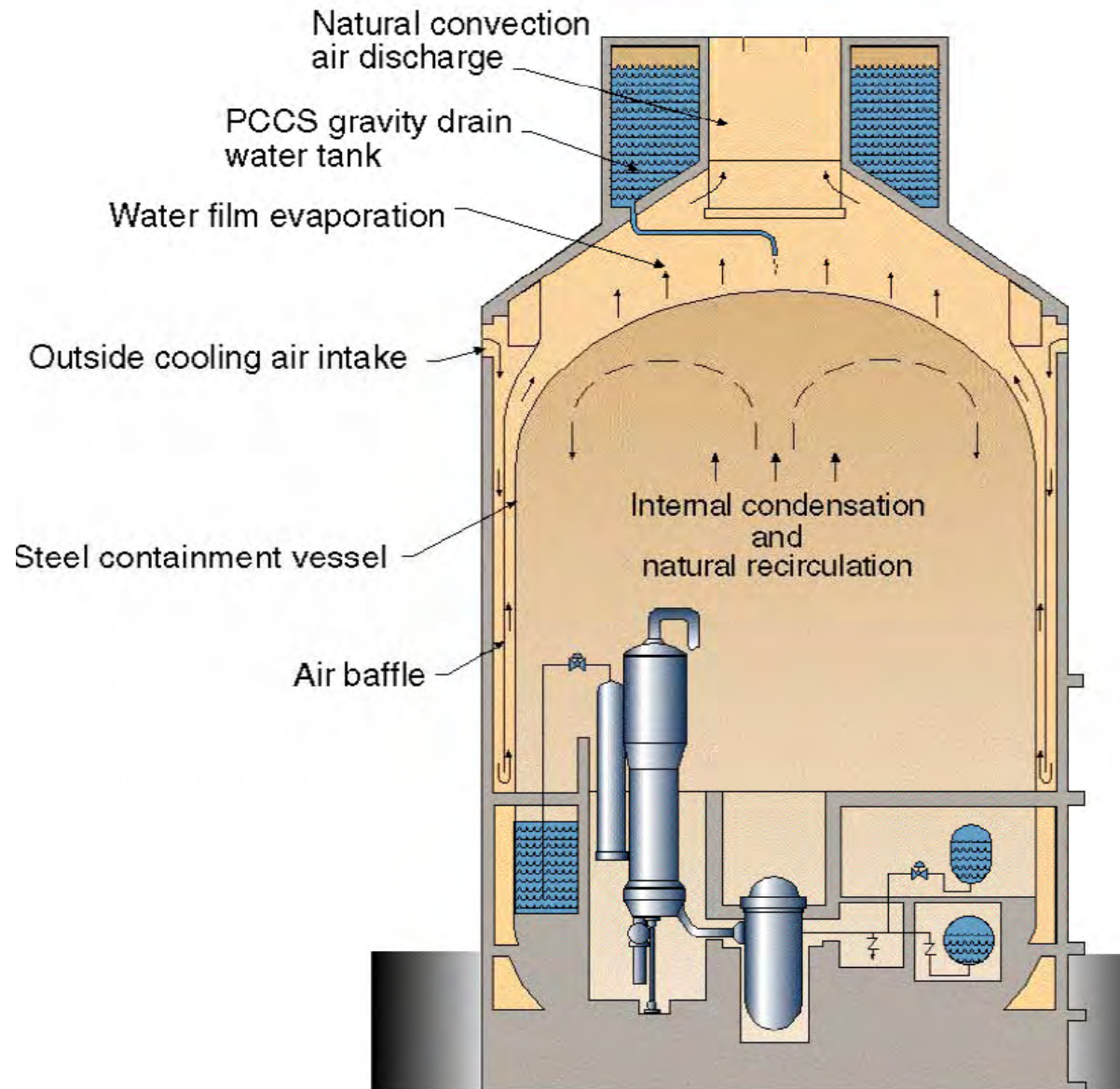

# Sigurnosni limiti i postavne vrijednosti

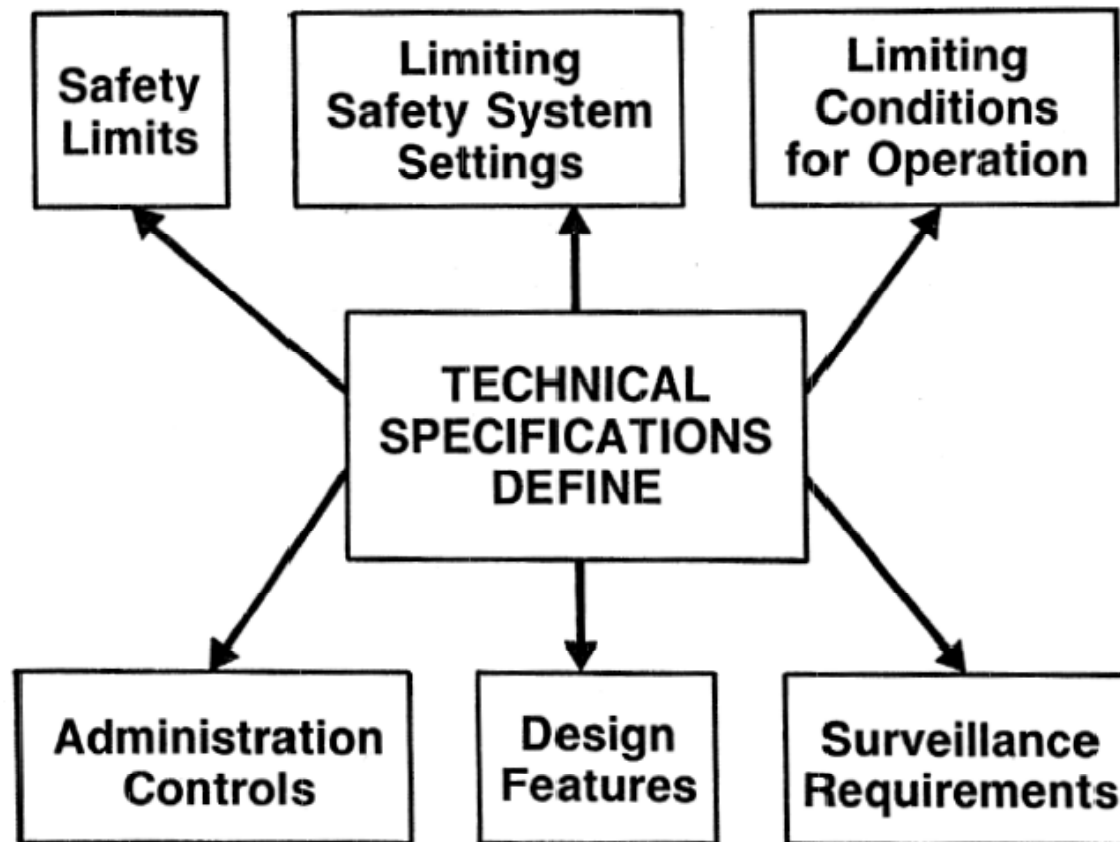

# Projektne margine

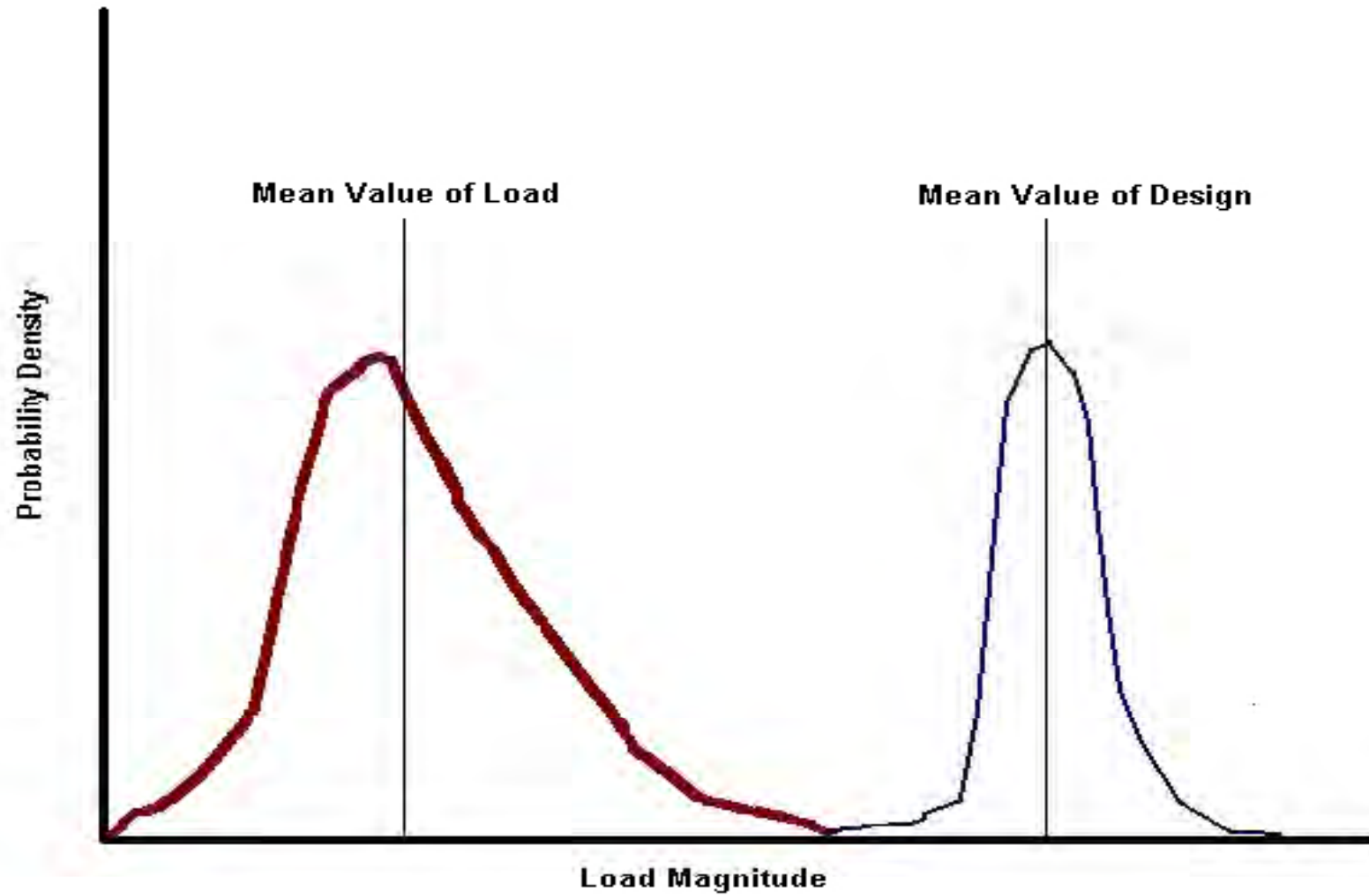

# Evolutivni PWR – EPR

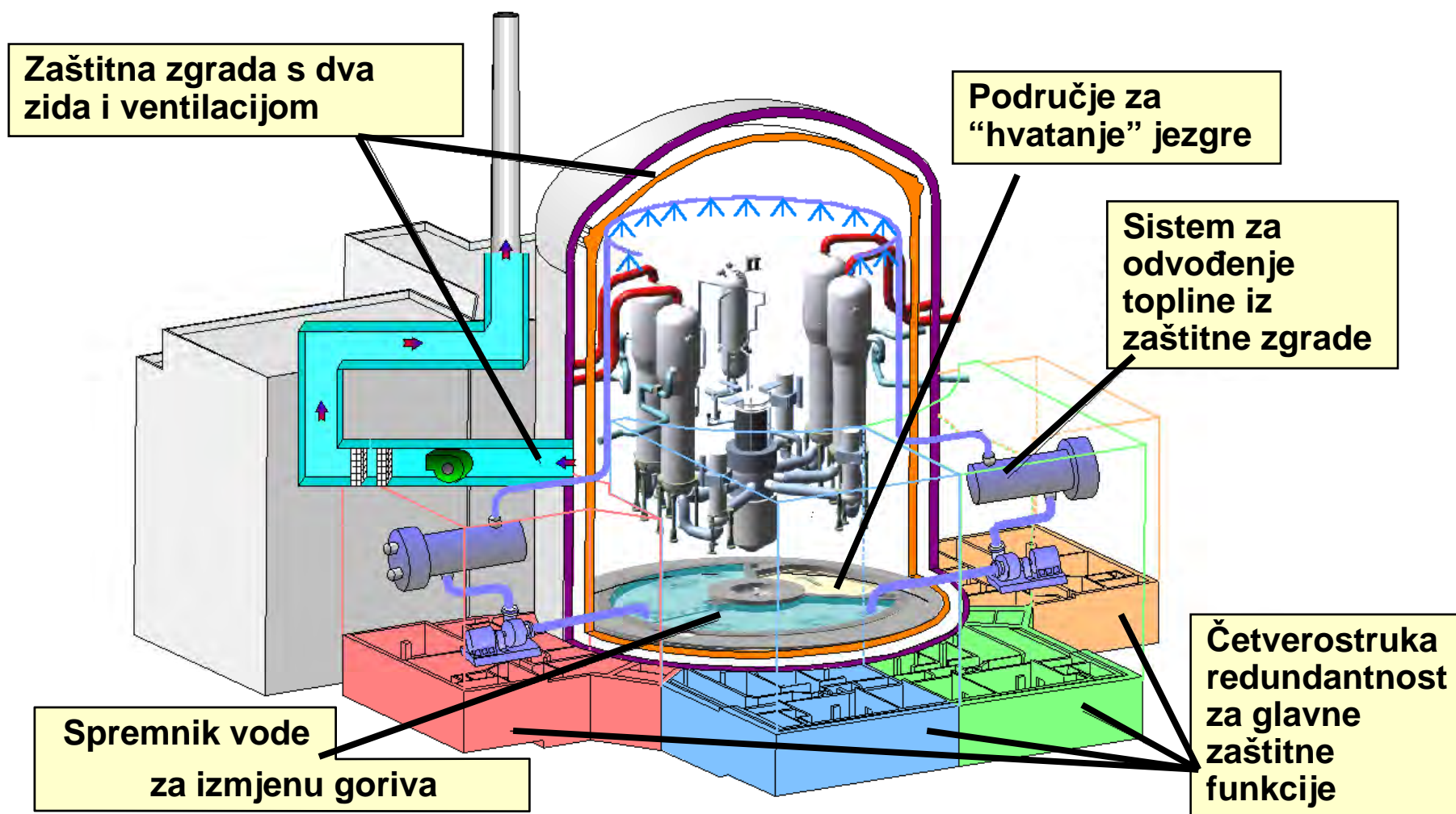

# Analize sigurnosti elektrane

- Cilj je demonstrirati da NE može biti u pogonu bez nepotrebnog rizika za zdravlje ljudi i sigurnost
- Aplikacija za pogonsku dozvolu uključuje dokumentirano stanje sigurnosti elektrane - sigurnosni izvještaj elektrane (Final Safety Analysis Report - FSAR)
- Sigurnosni izvještaj mora sadržavati analizu projekta i pogonskih svojstava elektrane da se pokaže postojanje sigurnosnih margina za sve relevantne sigurnosne limite za vrijeme normalnog pogona, tranzijenata i projektnih akcidenata za cijelo vrijeme života elektrane

# Događaji od značaja za sigurnost

- Svrha evaluiranja širokog spektra događaja u sigurnosnim analizama je da se ocjene sva pogonska stanja elektrane i da se demonstrira suglasnost s regulatornim zahtjevima i uvjetima navedenim u pogonskoj dozvoli
- Da se osigura sustavan pristup koristi se kategorizacija događaja po frekvenciji pojavljivanja, težini posljedica i prirodi poremećaja



# Unutarnji i vanjski inicirajući događaji

- 1. Normalni pogon**
- 2. Očekivani pogonski događaji**  
(frekvencija veća od  $1e-2$ /god)
- 3. Projektne nesreće (DBA)**  
(frekvencija  $1e-2$  do  $1e-5$  /god)
- 4. Izvan projektne (BDBA) i teške nesreće**  
(frekvencija  $1e-4$  do  $1e-5$  /god CDF  
frekvencija  $1e-5$  do  $1e-6$  /gof LRF)

# **Funkcionalna klasifikacija događaja**

- 1. Increase In Heat Removal By The Secondary System**
- 2. Decrease In Heat Removal By The Secondary System**
- 3. Decrease In Reactor Coolant System Flow Rate**
- 4. Reactivity And Power Distribution Anomalies**
- 5. Increase In Reactor Coolant Inventory**
- 6. Decrease In Reactor Coolant Inventory**
- 7. Radioactive Release From A Subsystem Or**
- 8. Component**
- 9. Anticipated Transients Without Scram**

# Typični LOCA odziv

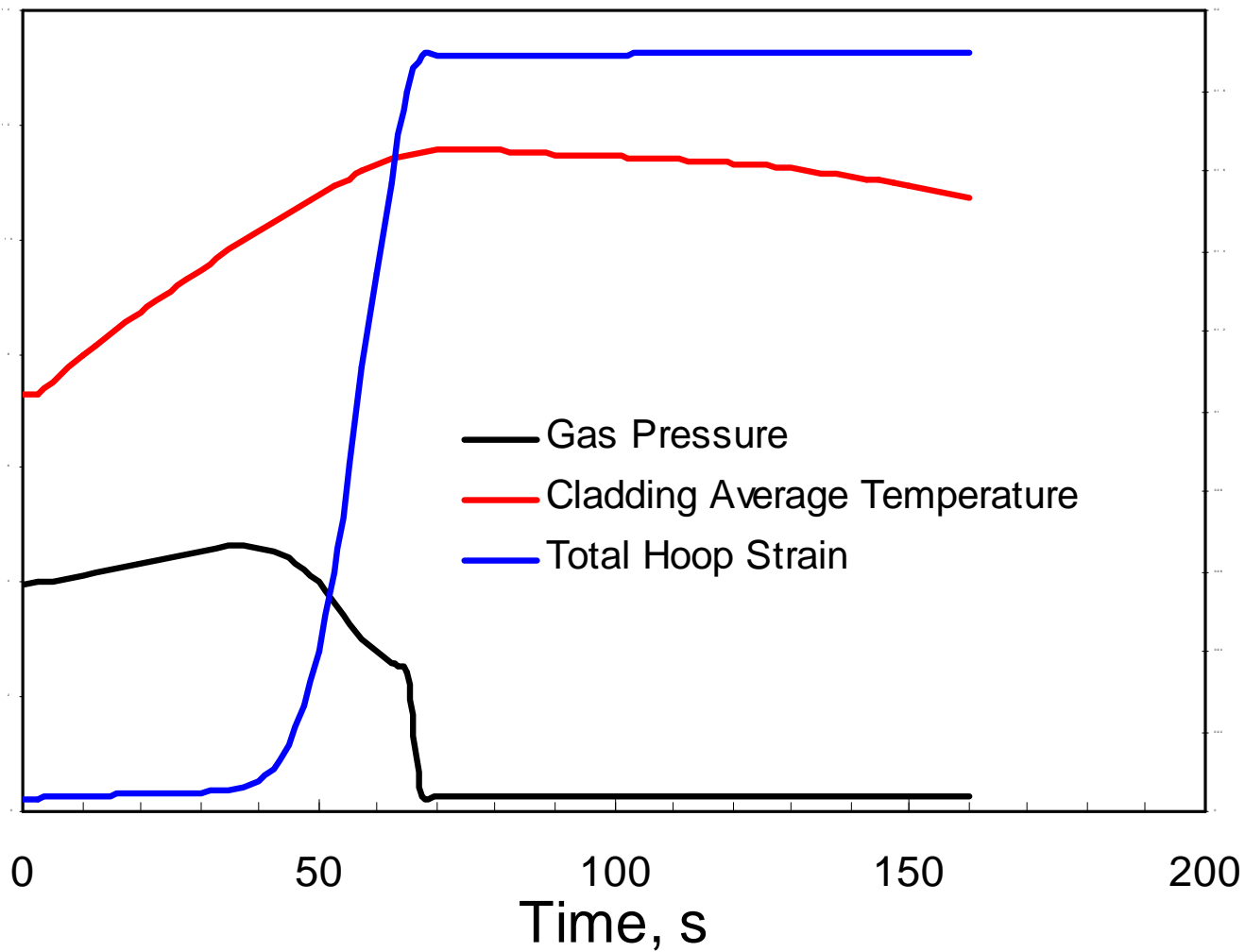

# Typični LOCA odziv

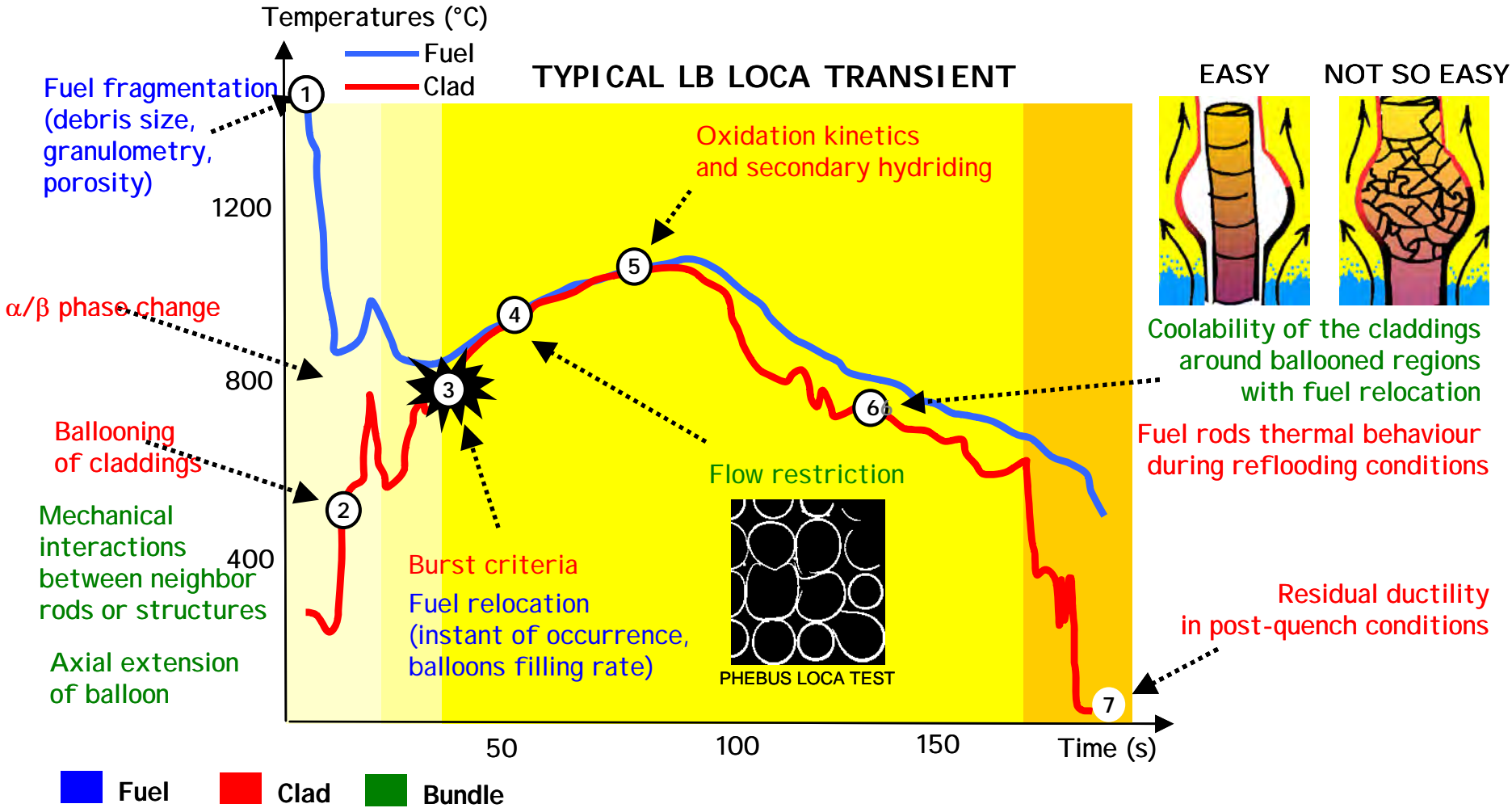

# LOCA temperatura košuljice

nek21e00 runid: cl loca

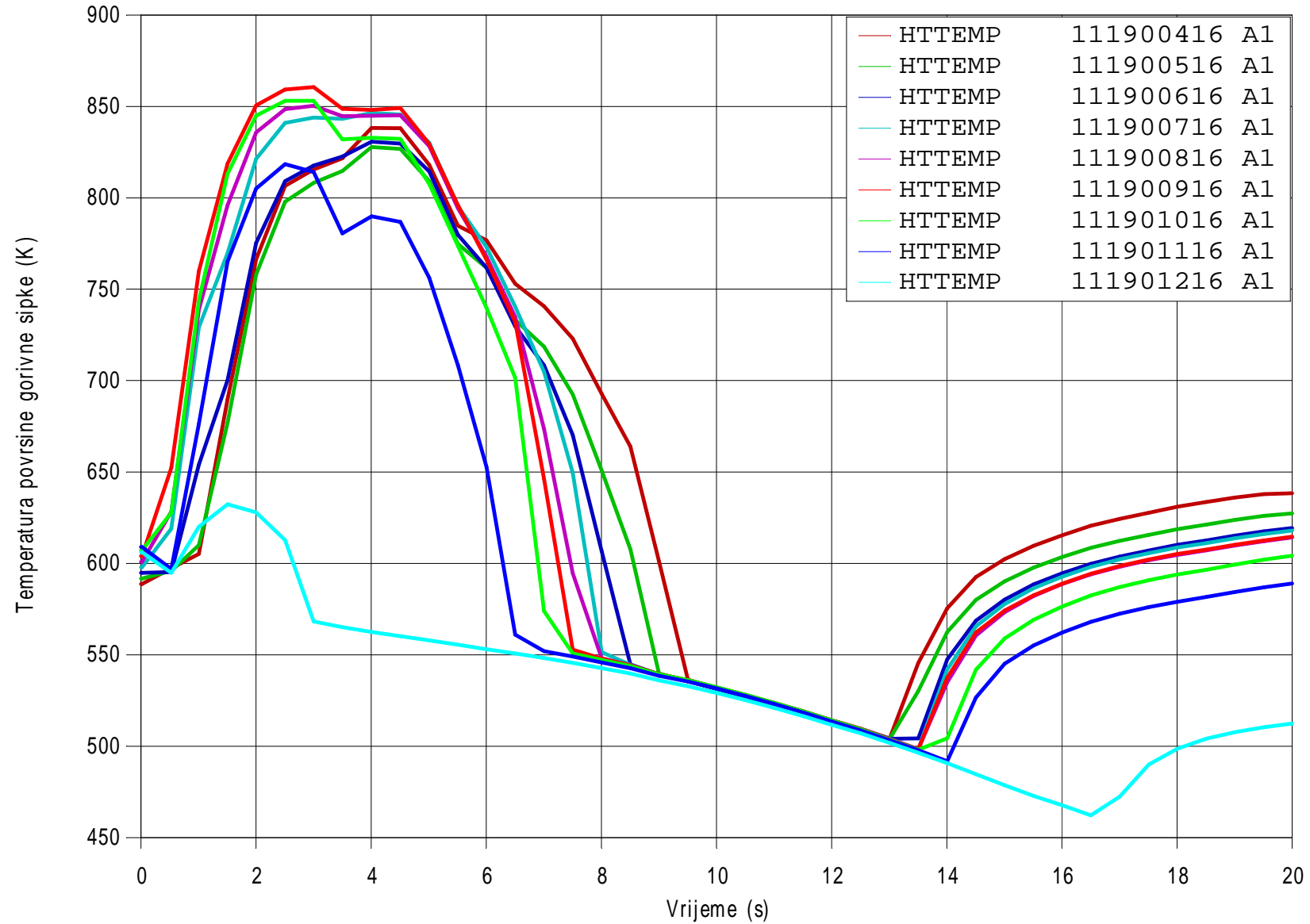

# Typični RIA odziv

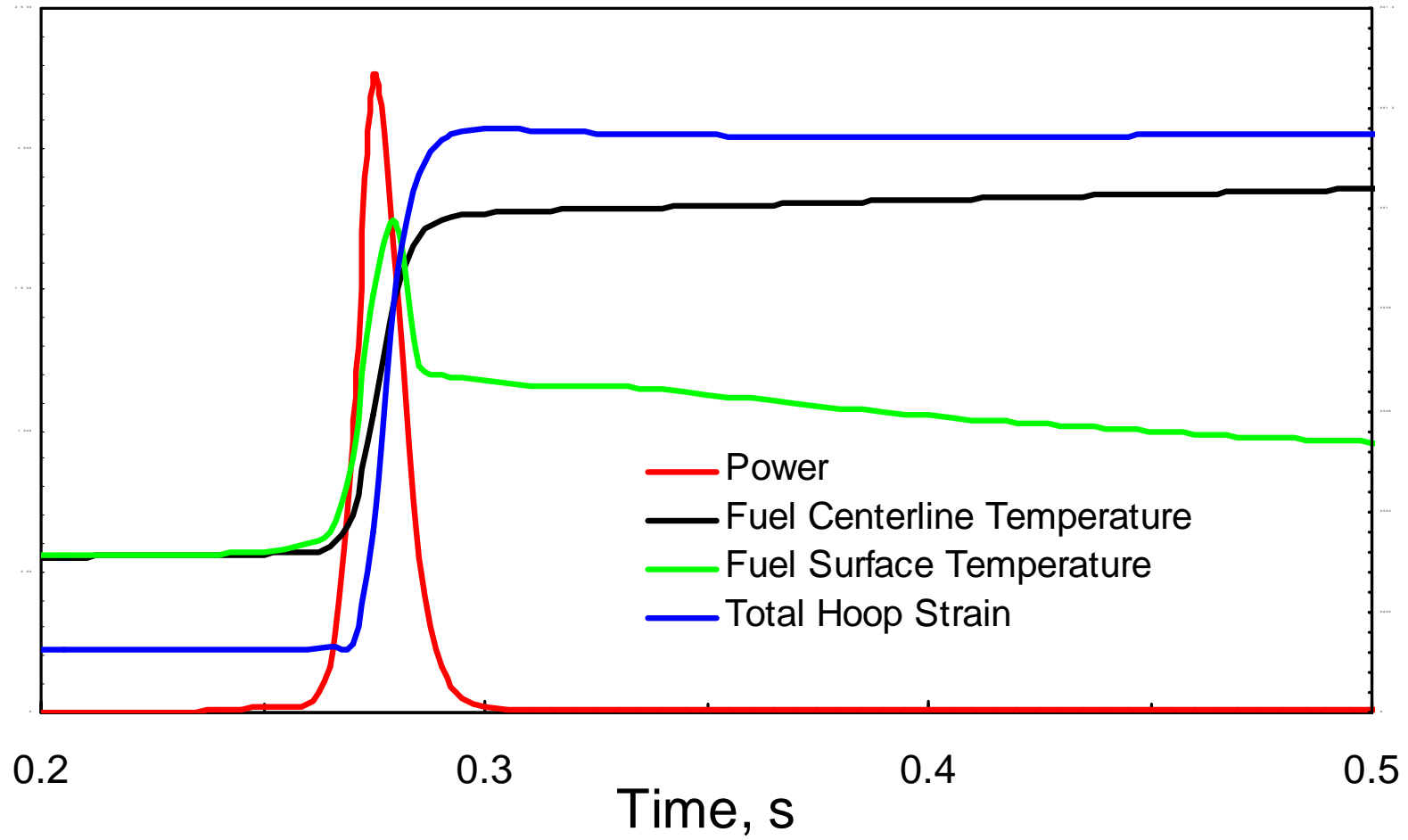

# Nuklearna snaga, izbacivanje RCCA HZP

Nuclear power rate

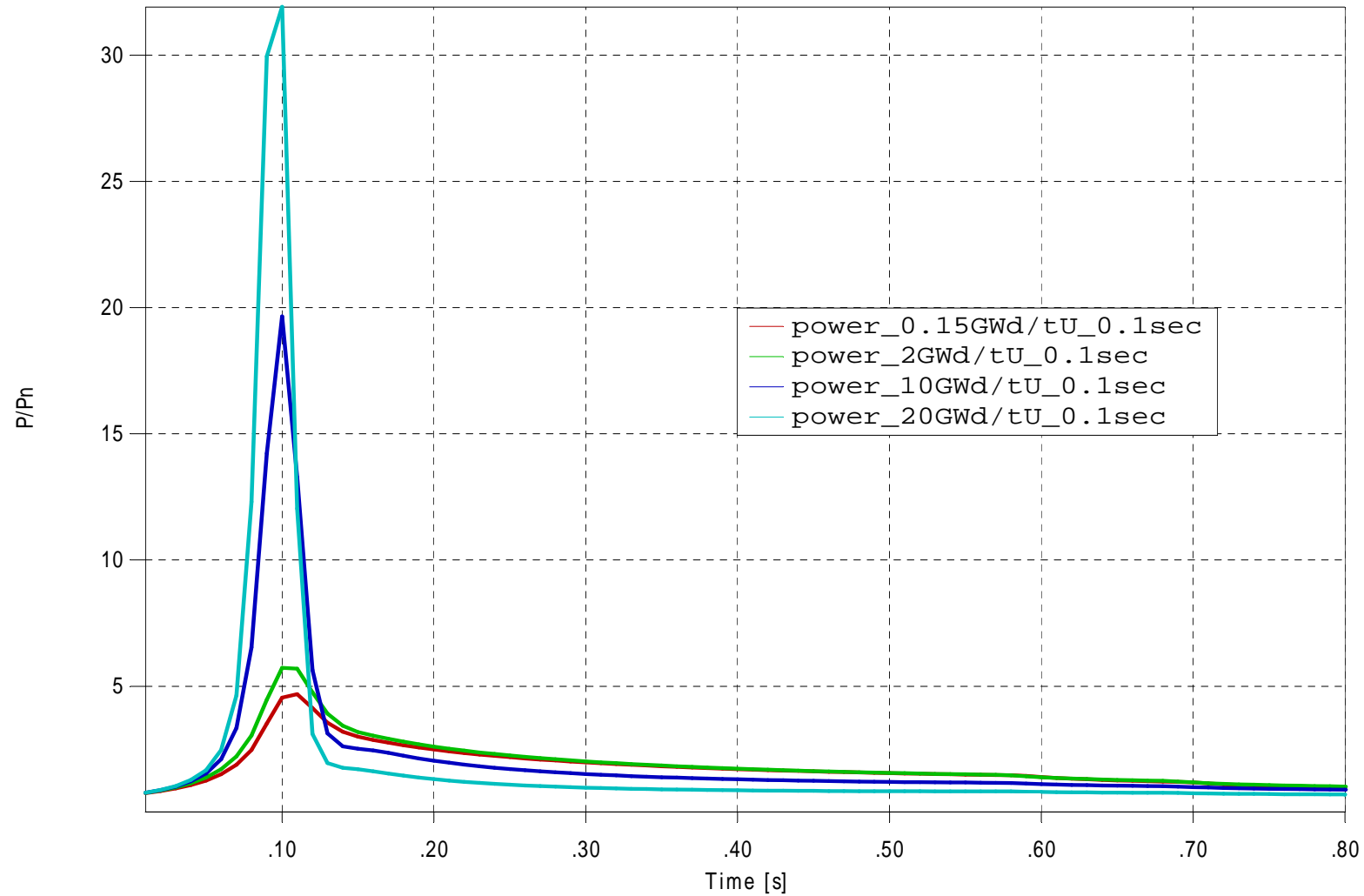

PLOT FER V1W 16:52:34, 02/04/06

# Tipični MSLB odziv

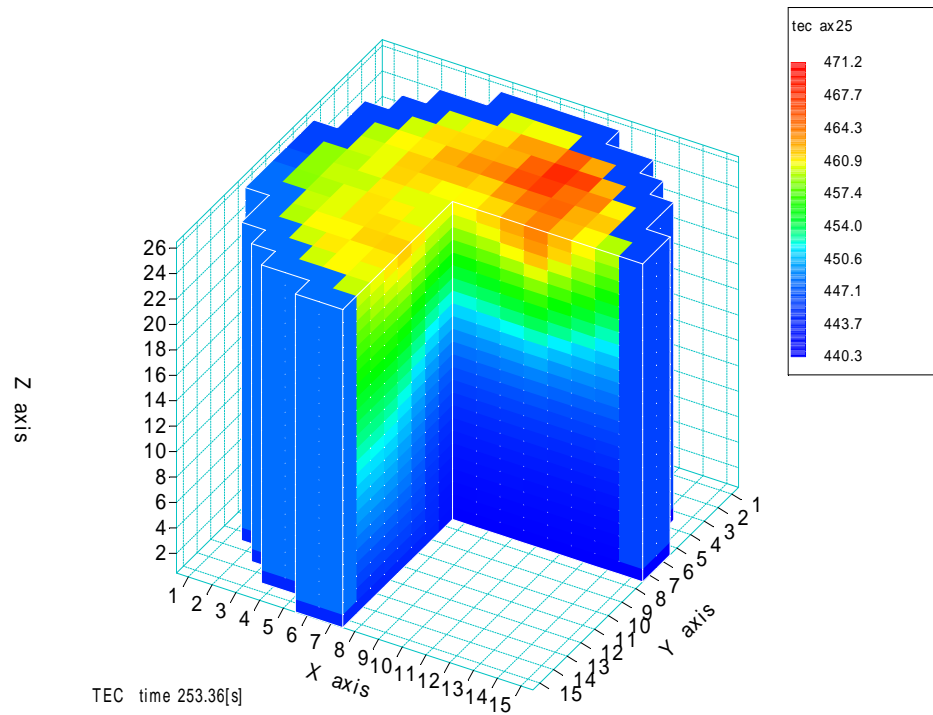
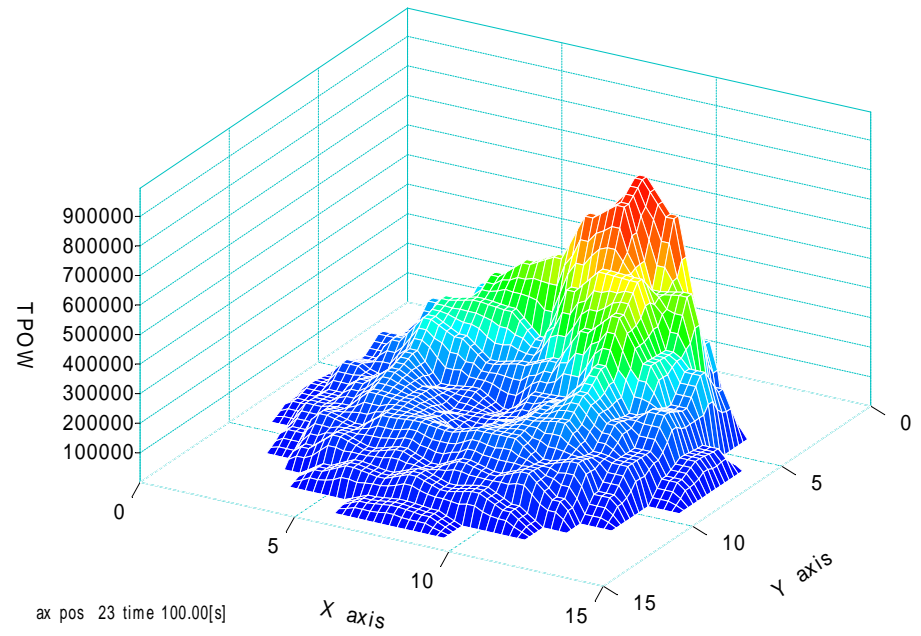



# Klasifikacija događaja po posljedicama

1. No Loss of Function of Any Barrier to Radioactivity Release
2. Damage to a Small Fraction of Fuel Elements
3. Radioactivity Releases up to 10CFR100 Limits
4. Radioactivity Releases in Excess of 10CFR100 Limits

# **Kvantitativni kriteriji prihvatljivosti**

- **FUEL TEMPERATURE**
- **FUEL ENERGY DEPOSITION**
- **CLAD HEAT TRANSFER**
- **CLAD TEMPERATURE**
- **CLAD INTEGRITY**
- **RADIOACTIVITY IN COOLANT**
- **PRIMARY OR SECONDARY SYSTEM PRESSURE**
- **CONTAINMENT PRESSURE**
- **RADIOACTIVITY IN CONTAINMENT**
- **DOSE IN CONTAINMENT**
- **DOSE TO SITE WORKERS**
- **DOSE AT SITE BOUNDARY**
- **DOSE IN LOW POPULATION ZONE**
- **DOSE TO THE PUBLIC**
- **PUBLIC HEALTH EFFECTS**

# Analyze sigurnosti - determinističke

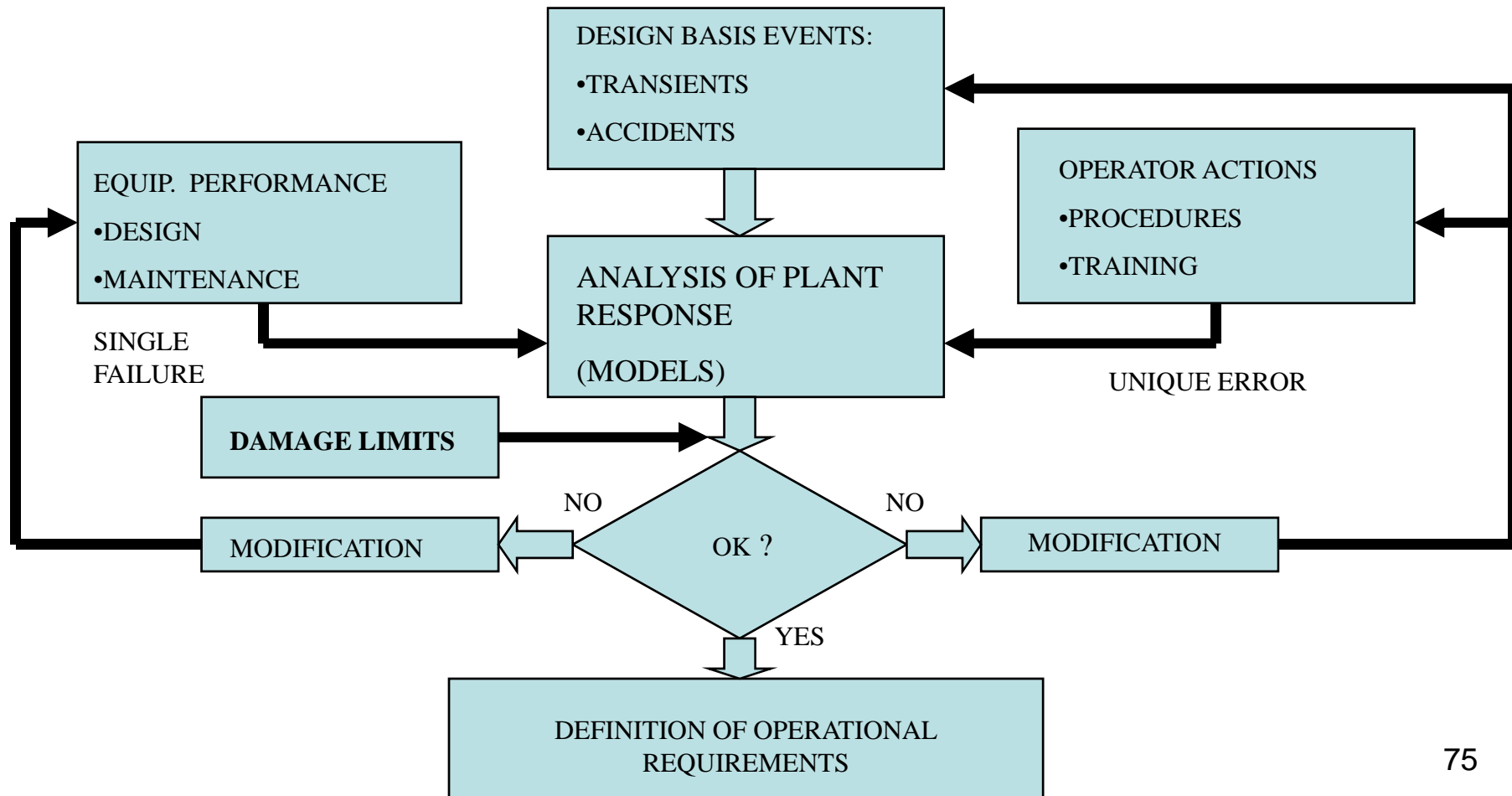

# Analyze sigurnosti - probabilističke

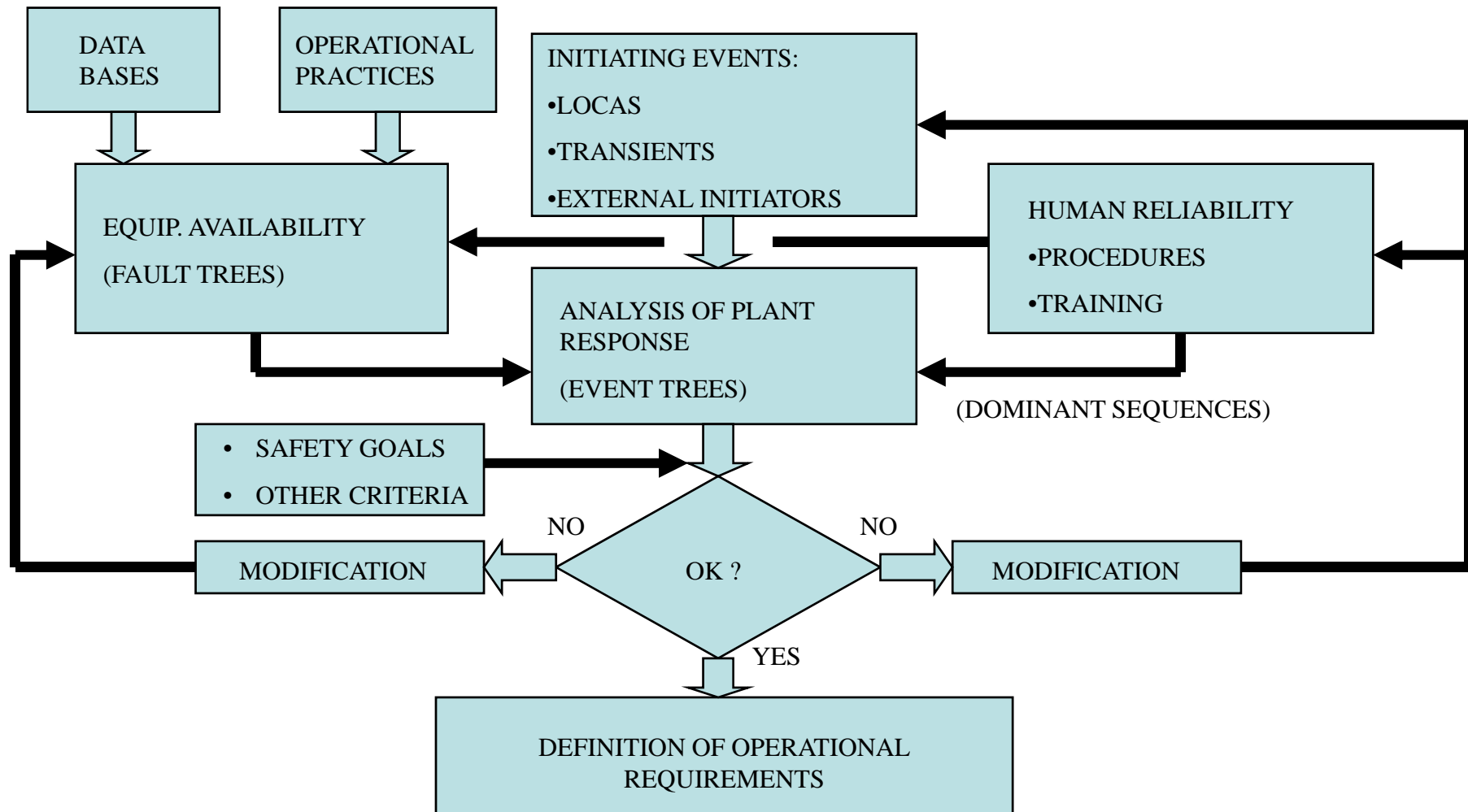

# Level 1 PSA

## Analysis of Core Damage Frequency

- Postulated initiating events
- Specification of safety system requirements
- Analysis of the event sequence
- Safety system failure analysis
- Data
- CCF (Common Cause Failures)
- HRA (Human Risk Assessment)
- Quantification of the analysis
- Results of the analysis of core damage frequency

## **Level 2 PSA**

### **Analysis of Accident Progression from Core Damage to Release of Radioactive Material**

- Definition of plant damage states
- Modelling of core damage progression
- Data
- Containment performance analysis
- Source term analysis
- Results of level 2 PSA
- On-site accident management

## **Level 3 PSA**

### **Analysis of the Off-site Consequences**

- Source term grouping
- Atmospheric dispersion modelling
- Meteorological data
- Population, Agricultural and Economic data
- Results of the societal risk estimates
- Off-site emergency planning

# Probabilistički sigurnosni pokazatelji

- Definiranje kriterija
- Numeričke vrijednosti
- Jedna od rijetkih industrija koja je prihvatila kvantitativne pokazatelje sigurnosti

	CDF	Large releases
Existing NPP	$10^{-4}$	$10^{-5}$
New NPP	$10^{-5}$	$10^{-6}$



# Inovativni reaktori

Red veličine ukupne frekvencije taljenja jezgre nuklearnih reaktora

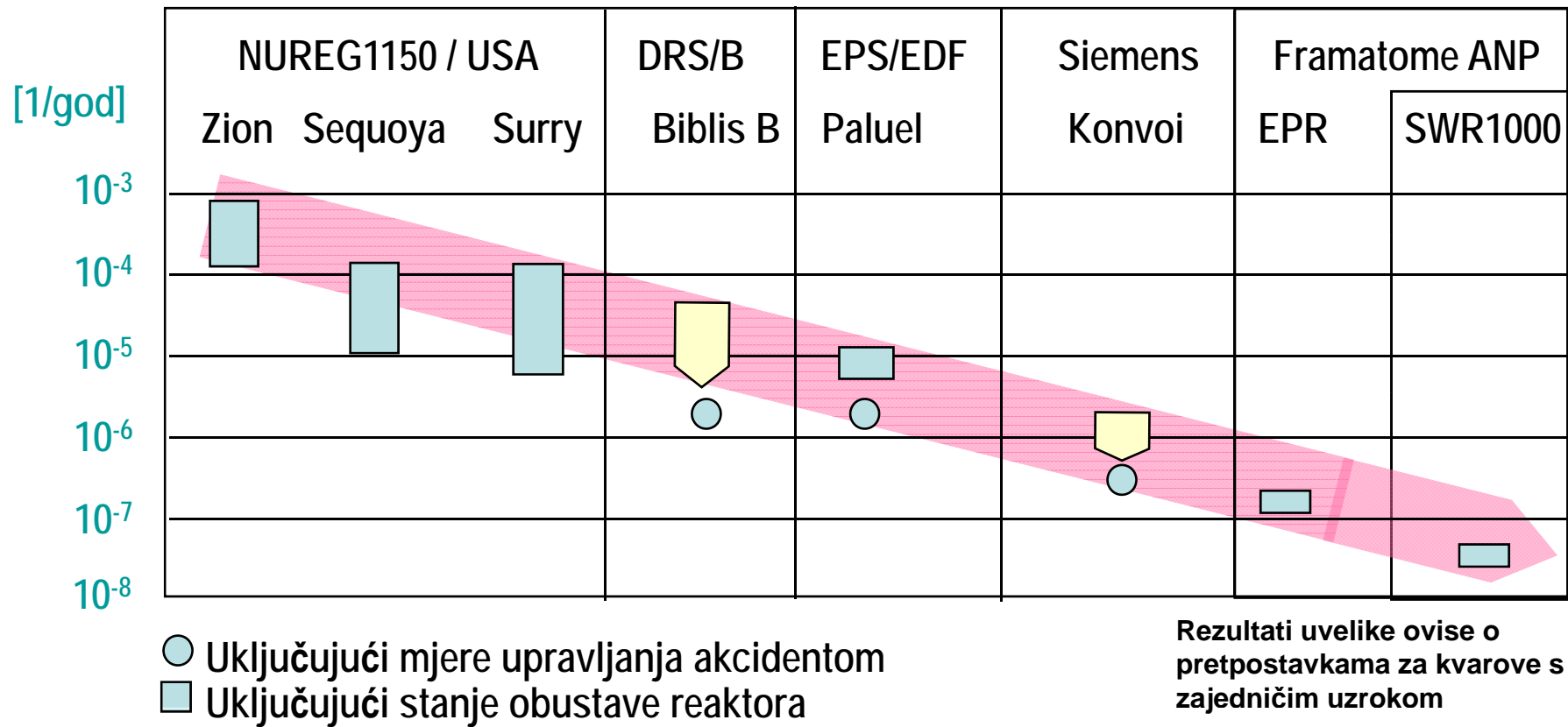

## Rezultati proračuna vjerojatnosti oštećenja jezgre prije i poslije promjene parogeneratorskog i drugih tehničkih poboljšanja u NEK

Inicijalni događaji	Prije tehničkih poboljšanja (stanje 1998. god)		Poslije tehničkih poboljšanja (stanje 2000. god)	
	Vjerojatnost oštećenja jezgre po godini pogona	Doprinos vjerojatnost i oštećenja jezgre %	Vjerojatnost oštećenja jezgre po godini pogona	Doprinos vjerojatnost i oštećenja jezgre %
<b>Interni događaji</b>	$5,34 \times 10^{-5}$	24,3	$4,2 \times 10^{-5}$	32,8
<b>Poplava*</b>	$4,55 \times 10^{-6}$	2,1	$4,53 \times 10^{-6}$	3,5
<b>Potres</b>	$5,68 \times 10^{-5}$	25,8	$5,67 \times 10^{-5}$	44,2
<b>Požar*</b>	$9,29 \times 10^{-5}$	42,2	$1,25 \times 10^{-5}$	9,8
<b>Ostali eksterni događaji</b>	$1,26 \times 10^{-5}$	5,5	$1,26 \times 10^{-5}$	9,8
<b>Ukupno</b>	$2,2 \times 10^{-4}$	100	$1,28 \times 10^{-4}$	100

\*Poplava i požar su unutarnji i vanjski događaji

# Rizik vezan za nuklearne elektrane

# Analize rizika

- **Determinističke i probabilističke analize su komplementarne**
- **Cilj je odrediti rizik od pogona nuklearnih elektrana**

## RIZIK:

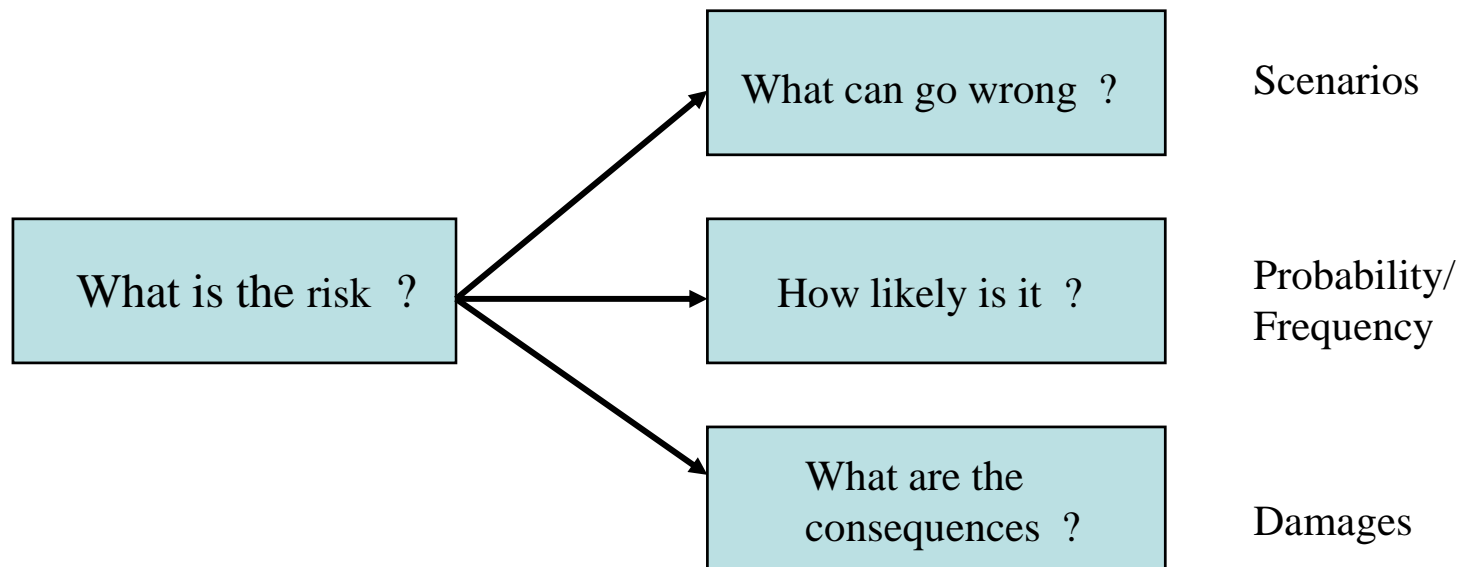

# How Does Risk Assessment Work?

- What are the risks from driving an automobile?
- There are 15,000,000 accidents per year, 1 in 300 of which result in death, there are 250,000,000 people

$$\textit{Societal Risk} = 15,000,000 \frac{\textit{accidents}}{\textit{year}} \times \frac{1}{300} \frac{\textit{deaths}}{\textit{accidents}} = 50,000 \frac{\textit{deaths}}{\textit{year}}$$

$$\textit{Individual Risk} = \frac{50,000 \textit{ deaths / year}}{250,000,000 \textit{ people}} = 2 \times 10^{-4} \frac{\textit{deaths}}{\textit{person} \cdot \textit{year}}$$

$$\textit{Lifetime Risk} = 2 \times 10^{-4} \frac{\textit{deaths}}{\textit{person} \cdot \textit{year}} \times 70 \textit{ years} = 0.014 (1 \textit{ in } 70)$$

# Farmerov model rizika

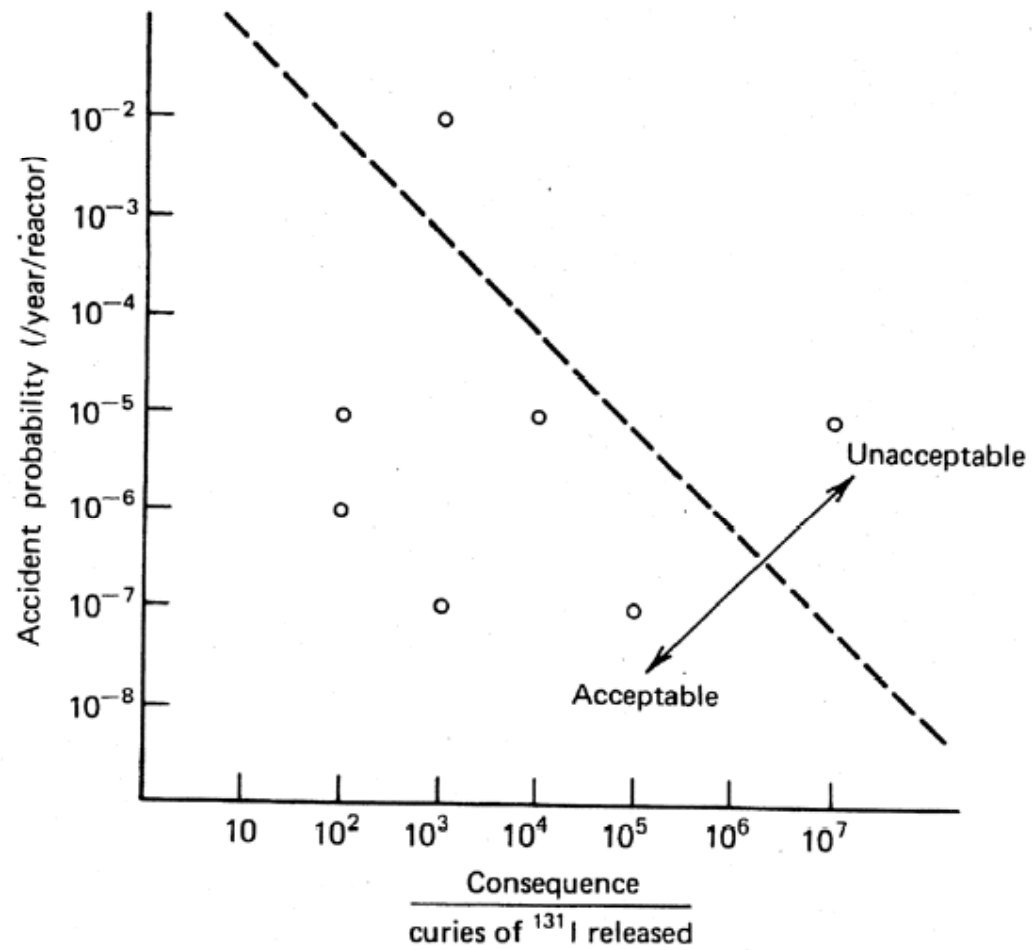

# Attitudes Towards Risk

- High Risk Activities are usually on the order of the Disease Mortality Rate :  
 $10^{-2}$  deaths/(person-yr)
- Low Risk Activities are usually on the order of the Natural Hazards Mortality Rate:  
 $10^{-6}$  deaths/(person-yr)

# Acceptability

- Acceptability Towards Risk depends on:
  - Benefits of Activity
  - Voluntary Nature of Activity
  - Perception
  - Consequence Distribution
- Consequence Distribution:
  - Given two activities with equal risk, the public will tend to accept Low Consequence-High Frequency Events more readily than High Consequence-Low Frequency Events.



- The annual risk of *prompt* death to the most exposed member of the public due to accidents in a reactor should be small in comparison to his/her total annual risk of prompt death due to all accidents.
- The annual risk of *fatal cancer* to the most exposed member of the public due to accidents in a reactor should be small in comparison to his/her total annual risk of fatal cancer due to all causes.

- Accidents fifth leading cause of death
- Rate of 37.9 deaths / 100,000 people /a
- Average person's risk of death from an accident is  $4 \times 10^{-4}$  per year, so e.g.:
- **'The likelihood of a large release from a nuclear power plant in an accident should be less than 4 per  $10^6$  reactor years'**

- Malignant neoplasm second leading cause of death
- Rate of 182.7 deaths per 100,000 people /a
- Average person's risk of dying from cancer is  $2 \times 10^{-3}$  per year ( $\sim 15\%$  over 75-years)
  - 100 person-Sv  $\Rightarrow \sim 5$  fatal cancers
  - "Averaged" risk of  $5 \times 10^{-2}$  fatal cancers per Sv
  - Equivalent dose is 0.04 Sv per year per person

- **Maximum time-averaged individual dose from accidents should be less than 0.4 mSv per year, averaged over a group of people**
  - ~ 40% natural background radiation
  - Should nuclear power be 'safer' than background radiation?
- Requires summation of all accidents

# Risk Assessment

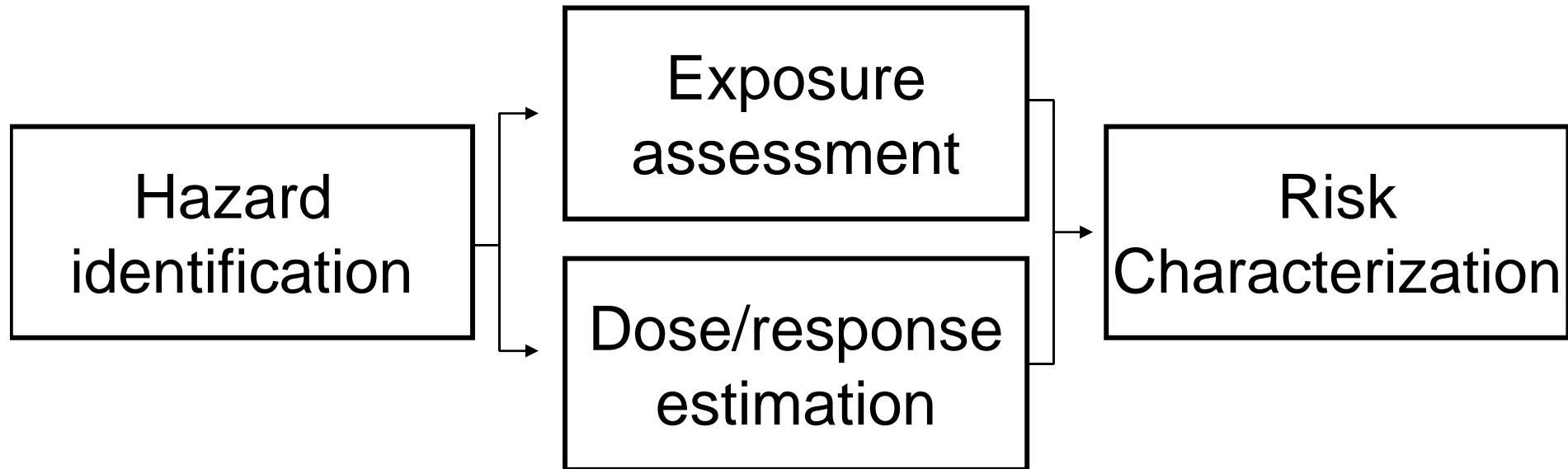

- Hazard identification uses toxicology (cell, tissue and animal tests) and epidemiology (population data and field samples)
- Exposure assessment includes determination of sources, environmental concentrations, exposure, dose, and uncertainties

# Framework for Risk Assessment

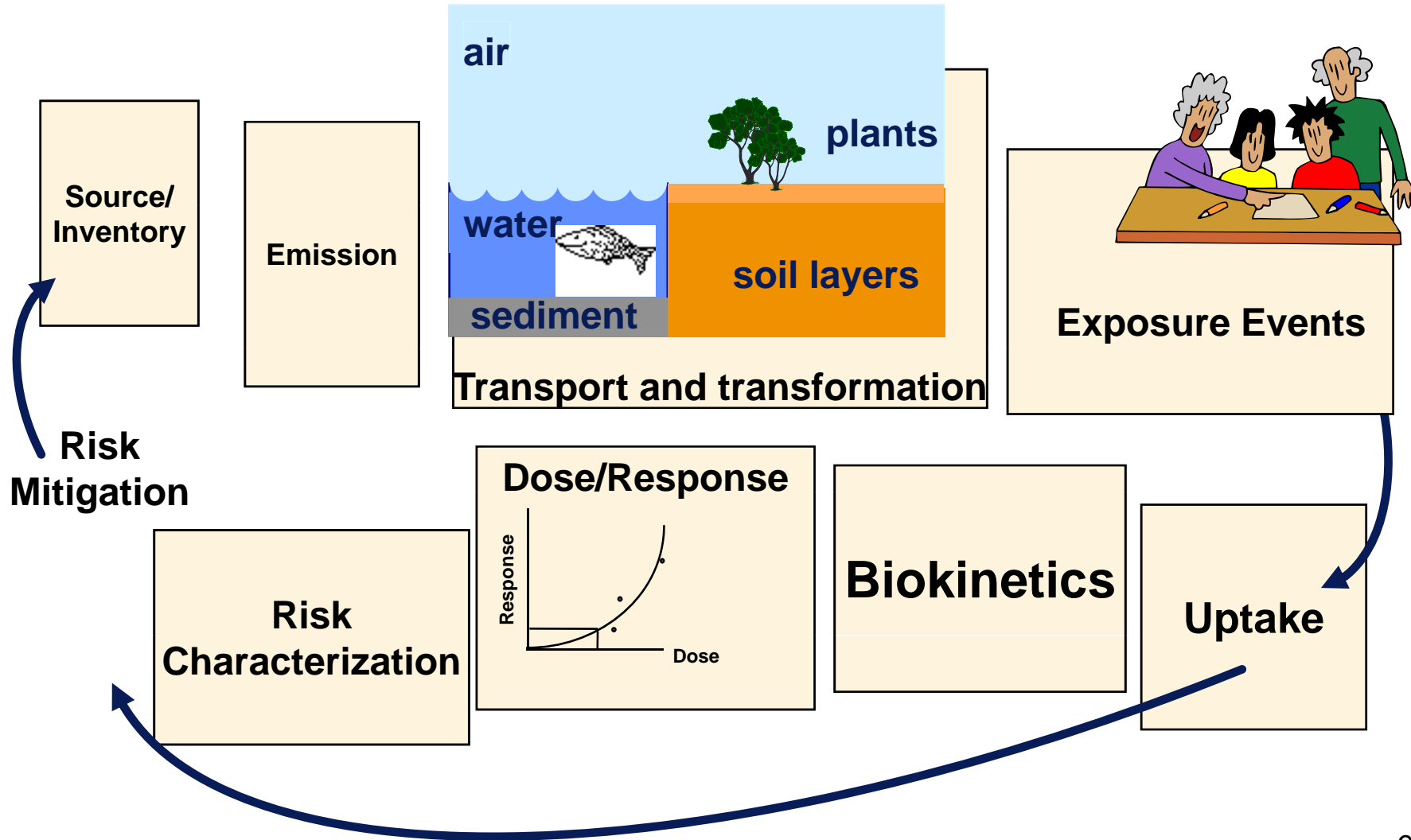

## **Rezultati studije sigurnosti WASH 1400**

- **Studija WASH 1400 usporedila je rizik stanovništva koje živi 30 km oko 66 USA lokacija od rada 100 nuklearnih elektrana na tim lokacijama s rizikom kojem je to isto stanovništvo (oko 15 milijuna ljudi) izloženo zbog drugih razloga.**
- **Očekivani godišnji broj ranih smrtnih slučajeva i bolesti 15 milijuna stanovnika koji žive na 30 km od lokacija američkih nuklearnih elektrana.**

# Rezultati studije sigurnosti WASH 1400

<b>Vrsta akcidenta</b>	<b>Rani smrtni slučajevi</b>	<b>Povrede</b>
<b>automobilske nesreće</b>	<b>4 200</b>	<b>375 000</b>
<b>padovi</b>	<b>1 500</b>	<b>75 000</b>
<b>požari</b>	<b>560</b>	<b>22 000</b>
<b>udari struje</b>	<b>90</b>	<b>?</b>
<b>udari gromova</b>	<b>8</b>	<b>?</b>
<b>pogon 100 nuklearnih reaktora</b>	<b>0,3</b>	<b>6</b>



# Rezultati studije sigurnosti WASH 1400

**Opći zaključci koji slijede iz studije jesu:**

- **akcidenti koji vode do oštećenja jezgre bez gubitka integriteta zaštitne posude vrlo malo utječu na okolinu,**
- **rizici od reaktorskih nesreća kojima je izloženo stanovništvo manji su od rizika koji nastaju zbog drugih uzroka u svakodnevnom životu,**
- **vjerojatnost nastanka reaktorskih akcidenata mnogo je manja od vjerojatnosti nastanka drugih nezgoda koje daju slične posljedice.**

# Njemačka studija rizika

- Njemačka studija rizika (Deutsche Rizikostudie Kernkraftwerke), izrađena je u dvije faze (faza A 1979. godine i faza B 1989. godine).
- U Njemačkoj su analizirani rizici stanovništva od rada 25 nuklearnih elektrana na 19 lokacija.
- Metoda primijenjena pri razradi njemačke studije rizika slična je metodi iz studije WASH 1400.
- Značajno je primijetiti da rezultati dobiveni u njemačkoj studiji rizika ne odstupaju bitno od onih u studiji WASH 1400.

# **Rezultati njemačke studije rizika**

## **Godišnji rizik od fatalne nesreće za milijun stanovnika u blizini nuklearnih elektrana u Njemačkoj**

<b>Uzrok i tip akcidenta</b>	<b>Prosječni godišnji broj ranih smrtnih slučajeva na milijun stanovnika</b>
rad u rudnicima	540
rad u zdravstvu	40
nesreće na radu (prosječno)	130
rad u domaćinstvu i rekreacijske aktivnosti	230
vožnja automobilom (75 min. dnevno)	240
vožnja avionom (1 sat tjedno)	50
udari struje	4
udari groma	0,6
rana smrt zbog nuklearnog akcidenta	0,01
smrt od raka zbog izlaganja zračenju kod nuklearnog akcidenta	0,2
smrt od raka zbog uzroka koji nisu vezani uz rad nuklearnih elektrana	2700

# Fizička sigurnost objekta i terorizam

# Poređenje veličine pojedinih meta

**WTC**  
208' wide  
1,353' tall

**Containment Building**  
130' wide  
160' tall

**Spent Fuel Pool**  
80' wide  
40' tall

**Fuel Storage  
containers**

**Pentagon**  
1,489' wide (921' per side)  
71' tall

10' wide  
20' tall



# Rezultat studije o padu/udaru aviona

Pretpostavke:

- Veliki putnički avion pun goriva
- Optimalni kut udara
- Optimalna brzina

Rezultati – nema oštećenja:

- Kontejnment
- Zgrada za istrošeno gorivo
- Kontejner za privremeno spremanje/transport goriva

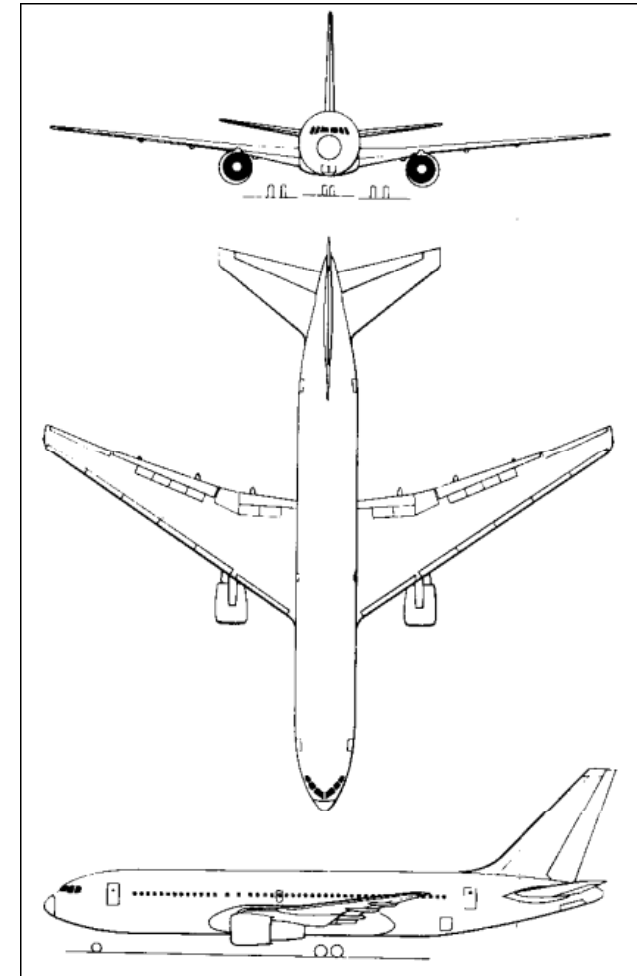

# Razmještaj objekata na lokaciji NE





# IRIS elektrana

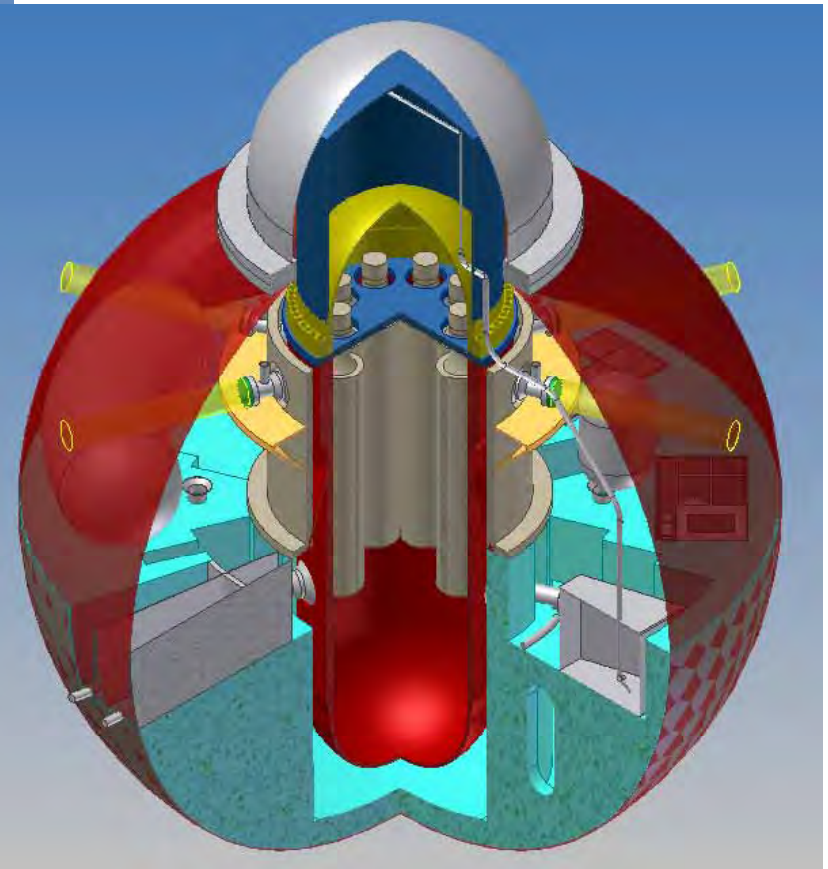
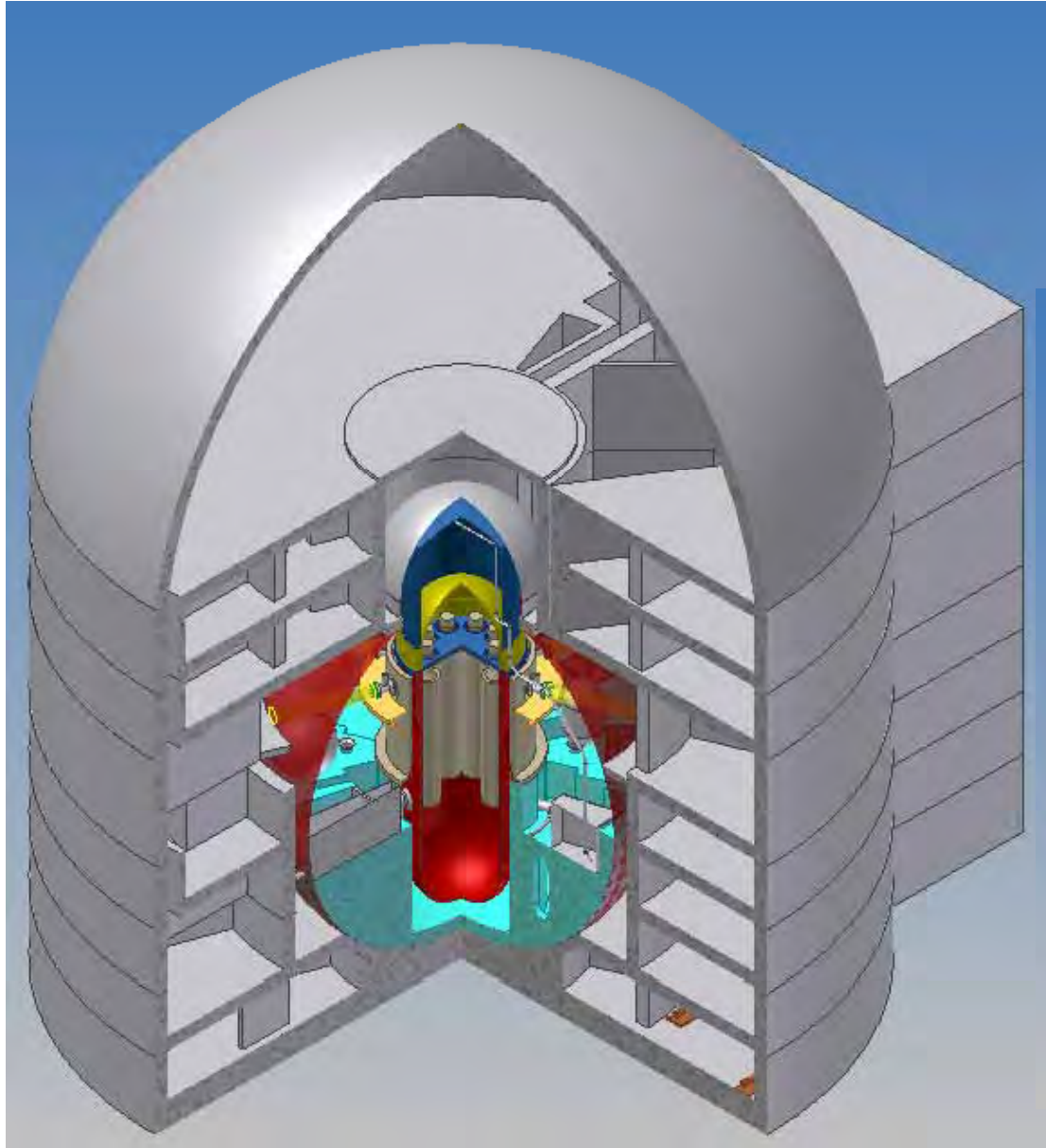



# Fizička sigurnost objekta

Owner-  
Controlled Area

Protected Area  
Double Fence

Protected  
Area

Vital Area

Access Control Points

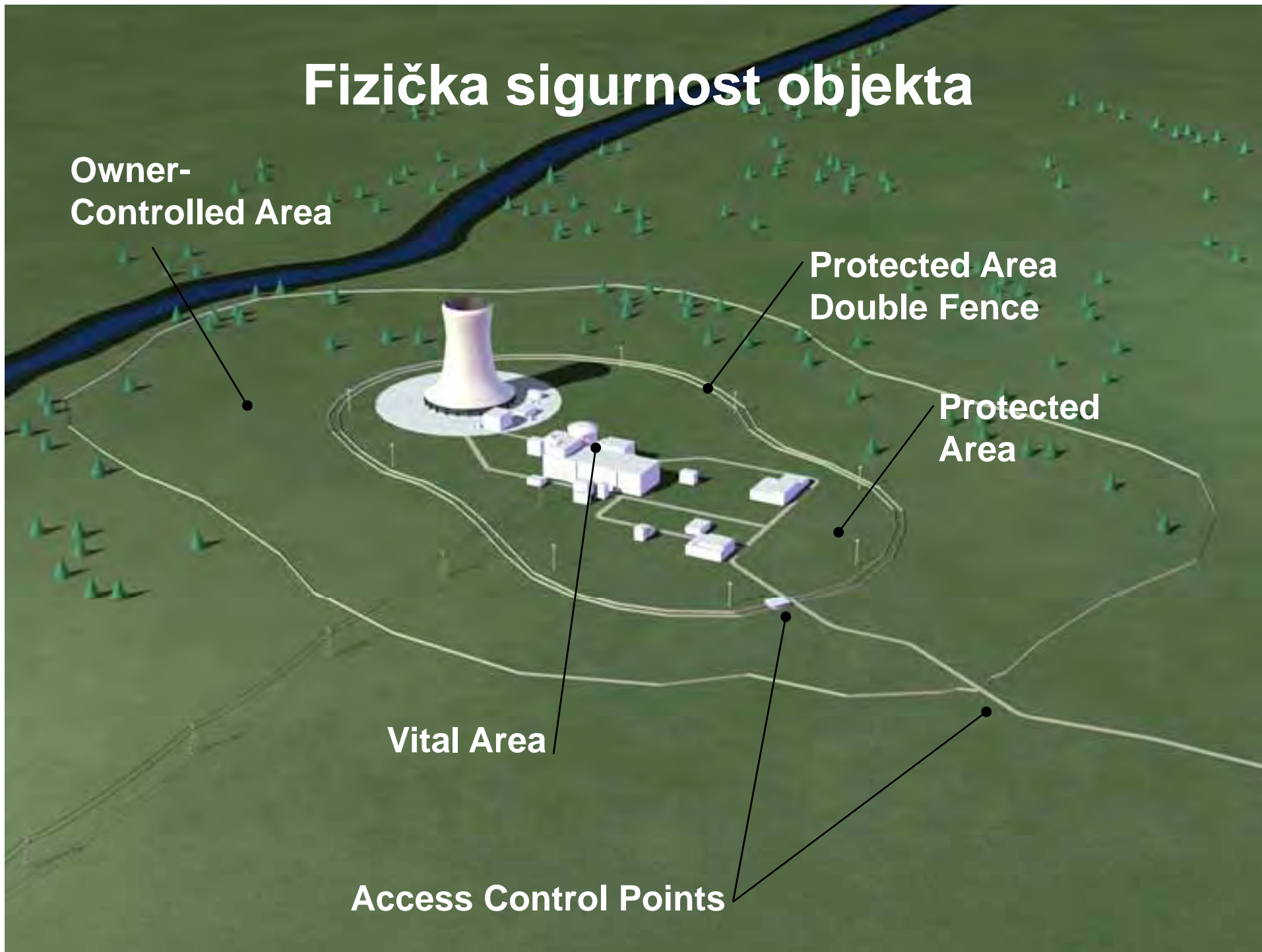

# Nuklearne nesreće

# Nuklearne nesreće

- **Da** li su moguće?
- **Da** li ih je bilo?
- Kako je do njih došlo?
  - Greške projektu
  - Greške u procedurama
  - Greške u treningu
  - Greške operatora u izvedbi
- Koji je dugoročni efekt?
  - Nuklearne elektrane su potvrdile loš glas koji prati nuklearnu energiju vezano za njene vojne početke
  - Unaprijedile su sigurnost (bolji projekti, procedure, školovanje, planiranje)

# Teške reaktorske nesreče eksperimentalni

Reactor	Date	Immediate Deaths	Environmental effect	Follow-up action
NRX, Canada (experimental, 40 MWt)	1952	Nil	Nil	Repaired (new core) closed 1992
Windscale-1, UK (military plutonium-producing pile)	1957	Nil	Widespread contamination. Farms affected (c $1.5 \times 10^{15}$ Bq released)	Entombed (filled with concrete) Being demolished.
SL-1, USA (experimental, military, 3 MWt)	1961	Three operators	Very minor radioactive release	Decommissioned
Fermi-1 USA (experimental breeder, 66 MWe)	1966	Nil	Nil	Repaired, restarted 1972
Lucens, Switzerland (experimental, 7.5 MWe)	1969	Nil	Very minor radioactive release	Decommissioned

# Teške reaktorske nesreče komercijalni

Reactor	Date	Immediate Deaths	Environmental effect	Follow-up action
<b>Browns Ferry, USA</b> (commercial, 2 x 1080 MWe)	1975	Nil	Nil	Repaired
<b>Three-Mile Island-2, USA</b> (commercial, 880 MWe)	1979	Nil	Minor short-term radiation dose (within ICRP limits) to public, delayed release of $2 \times 10^{14}$ Bq of Kr-85	Clean-up program complete, in monitored storage stage of decommissioning
<b>Saint Laurent-A2, France</b> (commercial, 450 MWe)	1980	Nil	Minor radiation release ( $8 \times 10^{10}$ Bq)	Repaired, (Decomm. 1992)
<b>Chernobyl-4, Ukraine</b> (commercial, 950 MWe)	1986	31 staff and firefighters	Major radiation release across E.Europe and Scandinavia ( $11 \times 10^{18}$ Bq)	Entombed
<b>Vandellos-1, Spain</b> (commercial, 480 MWe)	1989	Nil	Nil	Decommissioned

# Nesreća u TMI-2

March 28, 1979, 4:00 am local time



# Nesreća u NE Otok tri milje TMI-2

## Sekvenca događaja

1. Kvar sustava za demineralizaciju pojne vode parogeneratorsa
2. Ispad pumpi pojne vode
3. Ventil sustava pomoćne pojne vode ostao zatvoren što operateri nisu primijetili
4. Gubitak vode na sekundarnoj strani parogeneratorsa
5. Pregrijavanje primarnog kruga, porast tlaka, obustava reaktora
6. Otvaranje rasteretnih ventila tlačnika – ostali otvoreni!
7. Primarna voda se gubi, tlak pada, isparavanje vode
8. Operateri zaustavljaju primarne pumpe radi zaštite pumpi
9. Formiranje parnog mjehura u jezgri koji blokira protok vode kroz reaktor i potiskuje vodu u tlačnik
10. Operateri zaustavljaju rad pumpi sustava za zaštitno hlađenje jezgre
11. Pregrijavanje jezgre

# Dijelovi NE TMI-2 bitni za razumijevanje nesreće

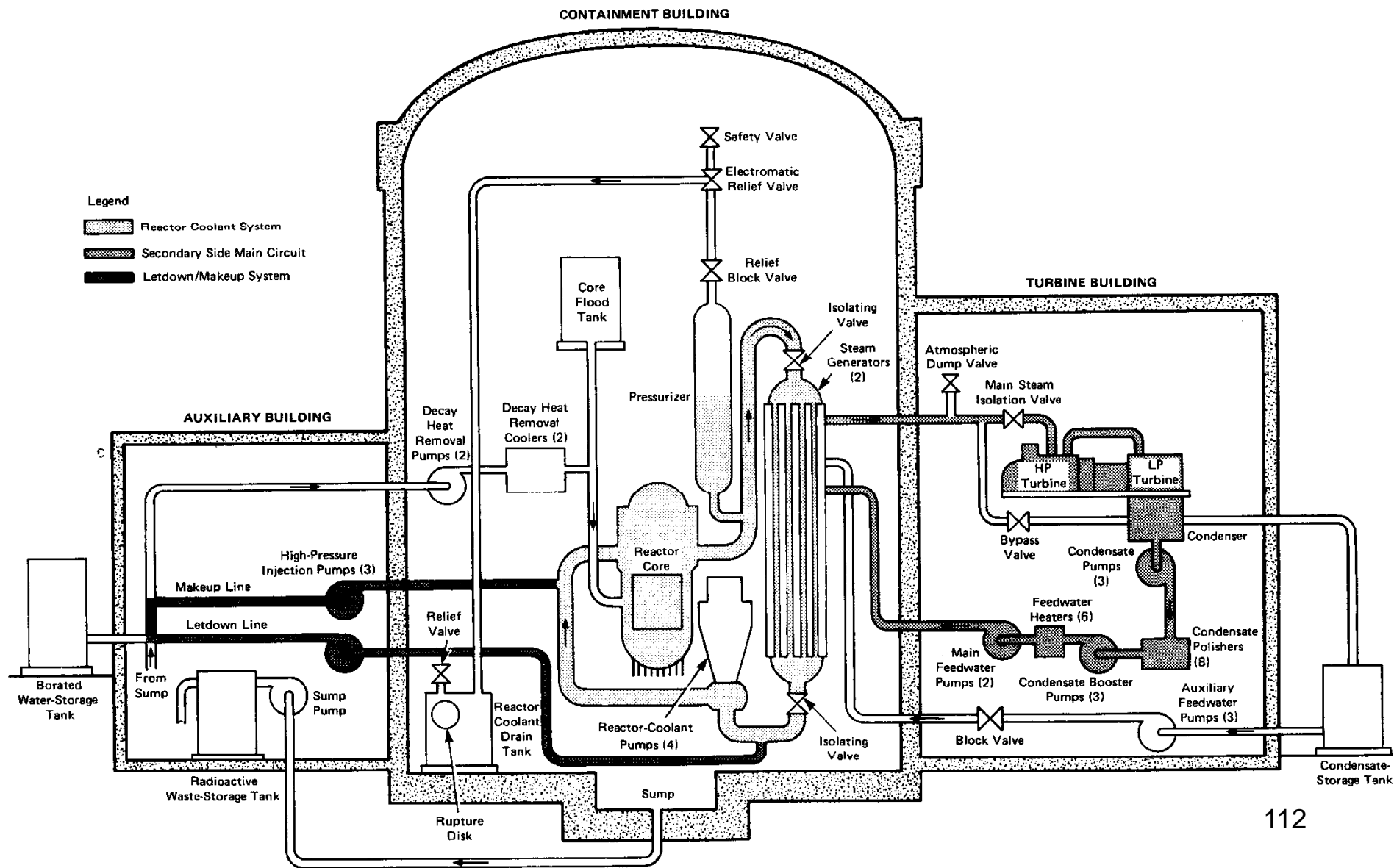



# Reaktorski sistem NE TMI-2

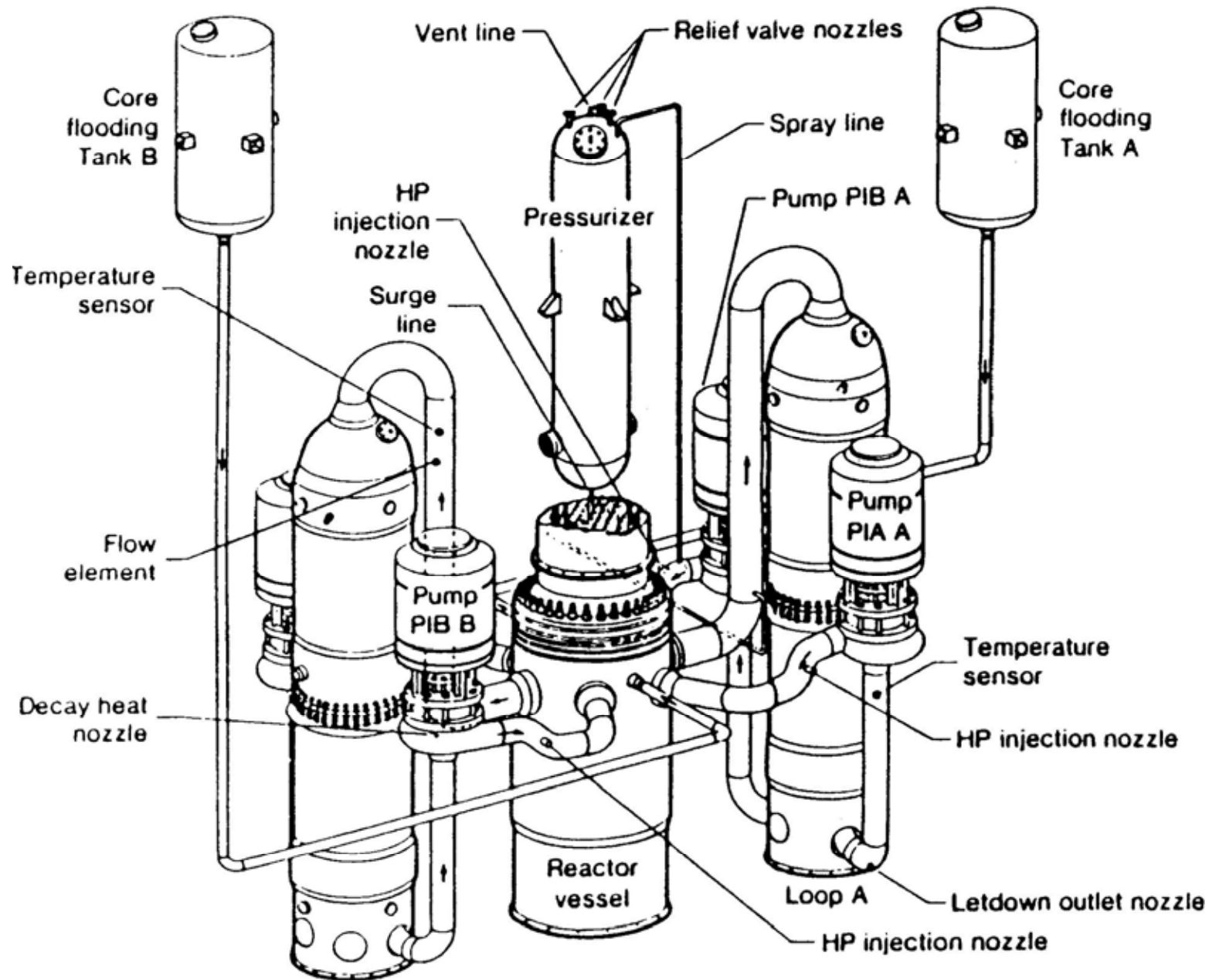

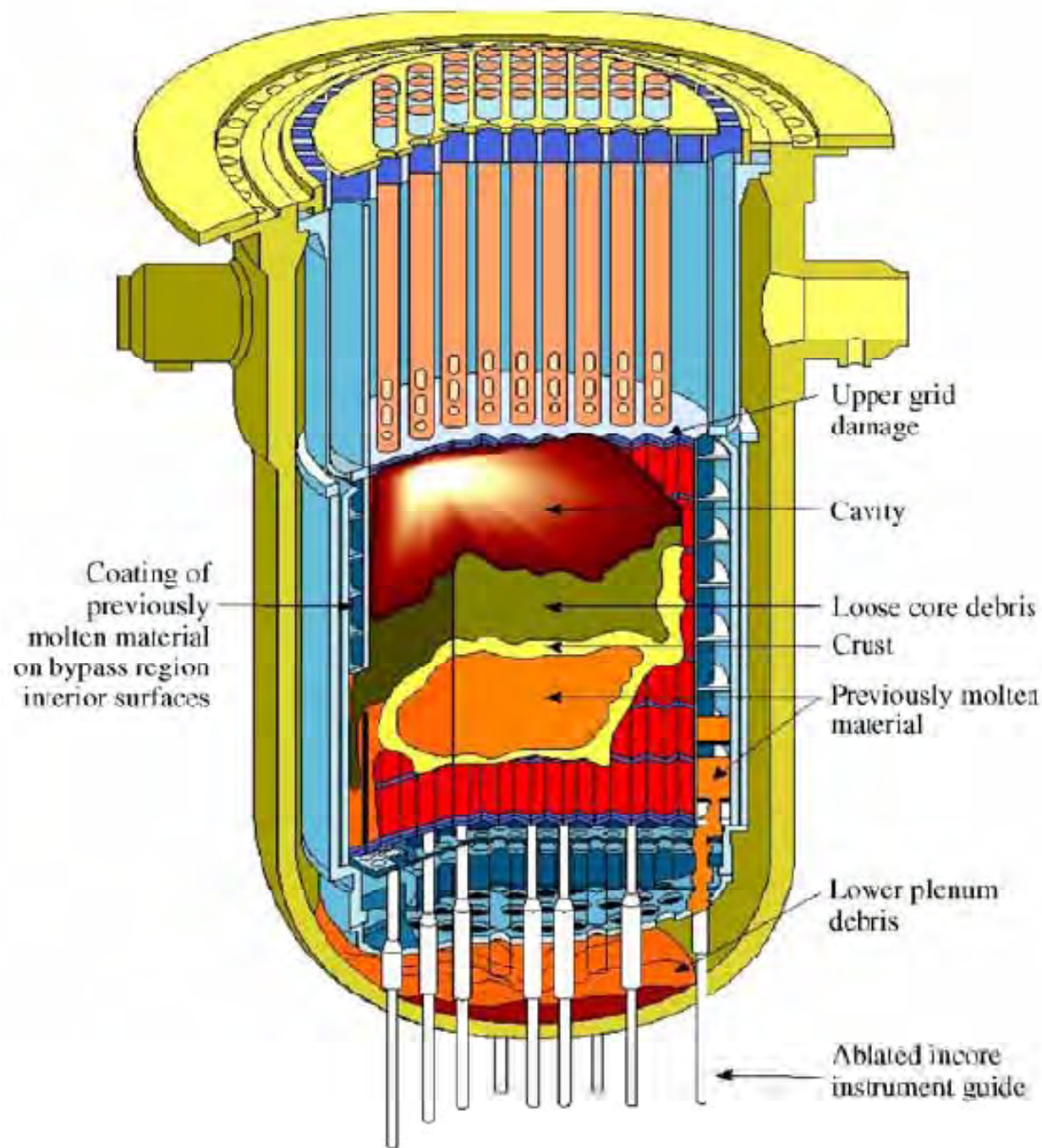

## Rezultat – oštećenje jezgre

Izvor topline:

-Ostatna toplina

-egzotermna reakcija  
oksidacije

Trajanje akcidenta:  
16 sati

## Nesreća u NE Otok tri milje TMI-2

- Nesreća na elektrani TMI-2 ukazala je na nedostatke u:
  - izvedbi elektrane
  - procedurama
  - obuci operatera
- Postalo je očigledno da do oštećenja jezgre može doći i kod malog ispuštanja iz primarnog sustava
- Znatno pooštreni sigurnosni zahtjevi ugradnjom novih tehničkih sustava i školovanjem operatera



# Akcident u Černobilu

- **NE Černobil je imala RBMK-1000 reaktor.**
- **Kao posljedica neoprezno izvedenog eksperimenta na jedinici 4, 26.04.1986., brzi porast snage izazvao je topljenje goriva i razaranje reaktorske zgrade. Slijedile se naknadne eksplozije, pare i vodika te požar grafita.**
- **Radioaktivni materijal je oslobađan u atmosferu tijekom 10 dana.**



# NE Černobil



# Izglede RBMK reaktora

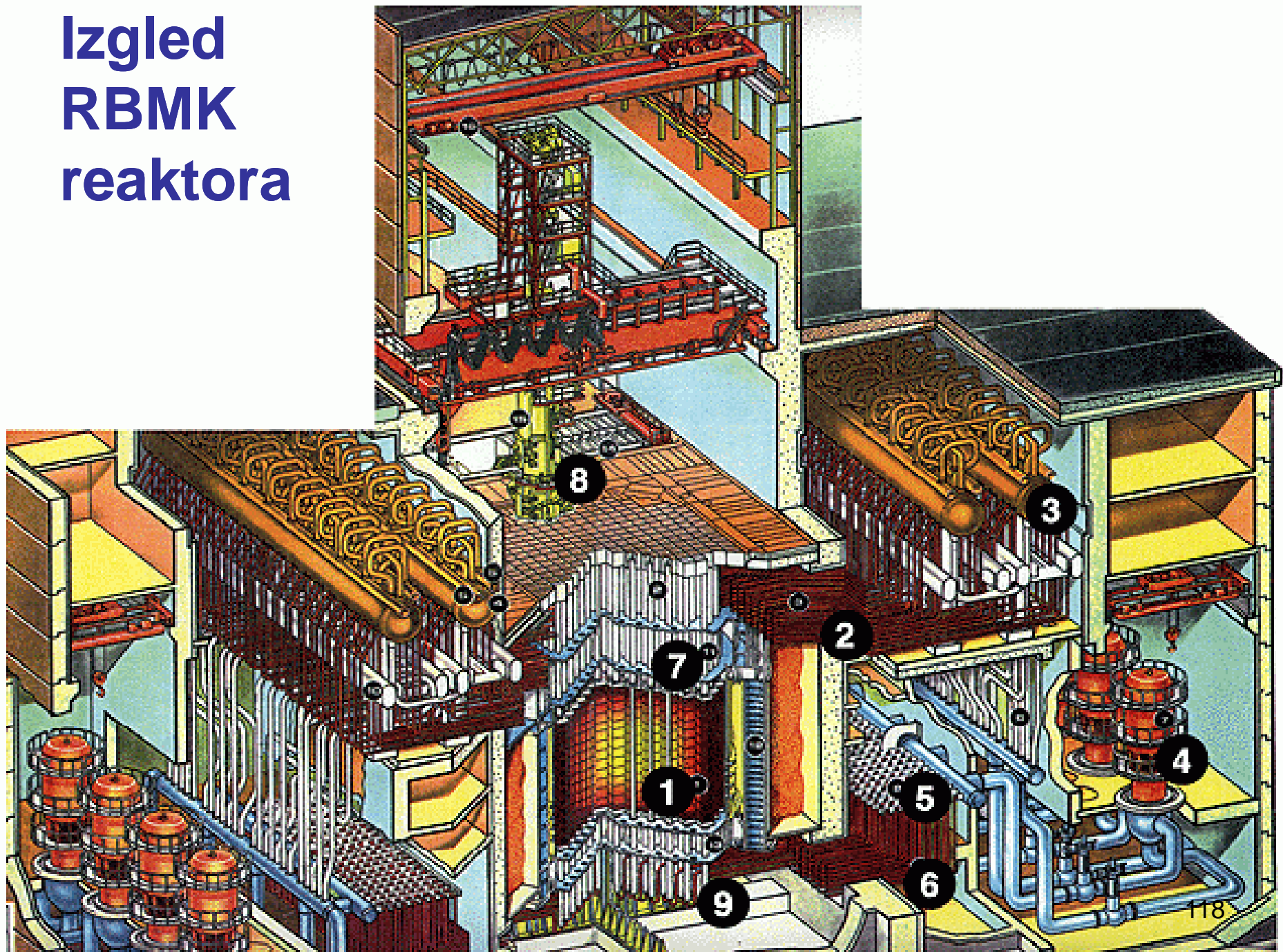

# RBMK-1000 reaktor

## **Prednost:**

- izmjena goriva tijekom pogona – visoka raspoloživost, te mogućnost reguliranja odgora goriva u pojedinim rashladnim kanalima bez potrebe za obustavom pogona

## **Nedostaci:**

- nema zaštitne zgrade
- pozitivan temperaturni koeficijent šupljina (najniža dopuštena termička snaga oko 22 % ukupne snage)
- sporo kretanje regulacijskih šipki (voda u kanalima jezgre ograničava njihovu brzinu kretanja)
- regulacijske šipke u svojem gornjem i donjem dijelu sadrže grafit umjesto apsorpcijskog materijala

# Nesreća u NE Černobil

**Eksperiment – da li nakon gubitka vanjskog napajanja električnom energijom turbina u zaustavljanju može proizvesti dovoljno električne energije za napajanje sustava za zaštitno hlađenje jezgre prije starta dizel generatora**

- plan je bio izvesti eksperiment na 30 % snage (nema tripa reaktora kako bi operateri imali mogućnost ponoviti eksperiment)
- eksperiment se trebao odnositi na ne-nuklearni dio elektrane
- nije bilo koordinacije između osoblja zaduženog za eksperiment i osoblja zaduženog za sigurnost elektrane



## Tijek događaja 25.04.1986.

- 01:06 počinje gašenje reaktora, postepeno smanjivanje snage, početak testa
- 03:47 zaustavljeno gašenje na 1600 MW(t), zahtjev kijevskog operatera da elektrana ostane na snazi
- 14:00 izoliran ECCS

## Tijek događaja 26.04.1986.

- 01:23:47 snaga reaktora na 30000 MW(t)
  - tlak pare ubrzano raste – prva eksplozija
  - razorena reaktorska zgrada – jezgra izložena atmosferi
  - taljenje gorivih elemenata
  - reakcija goriva i obloge – vodik – druga eksplozija
  - vrući grafit počinje gorjeti u dodiru s kisikom iz atmosfere

# Events Leading to Accident

## Tijek događaja

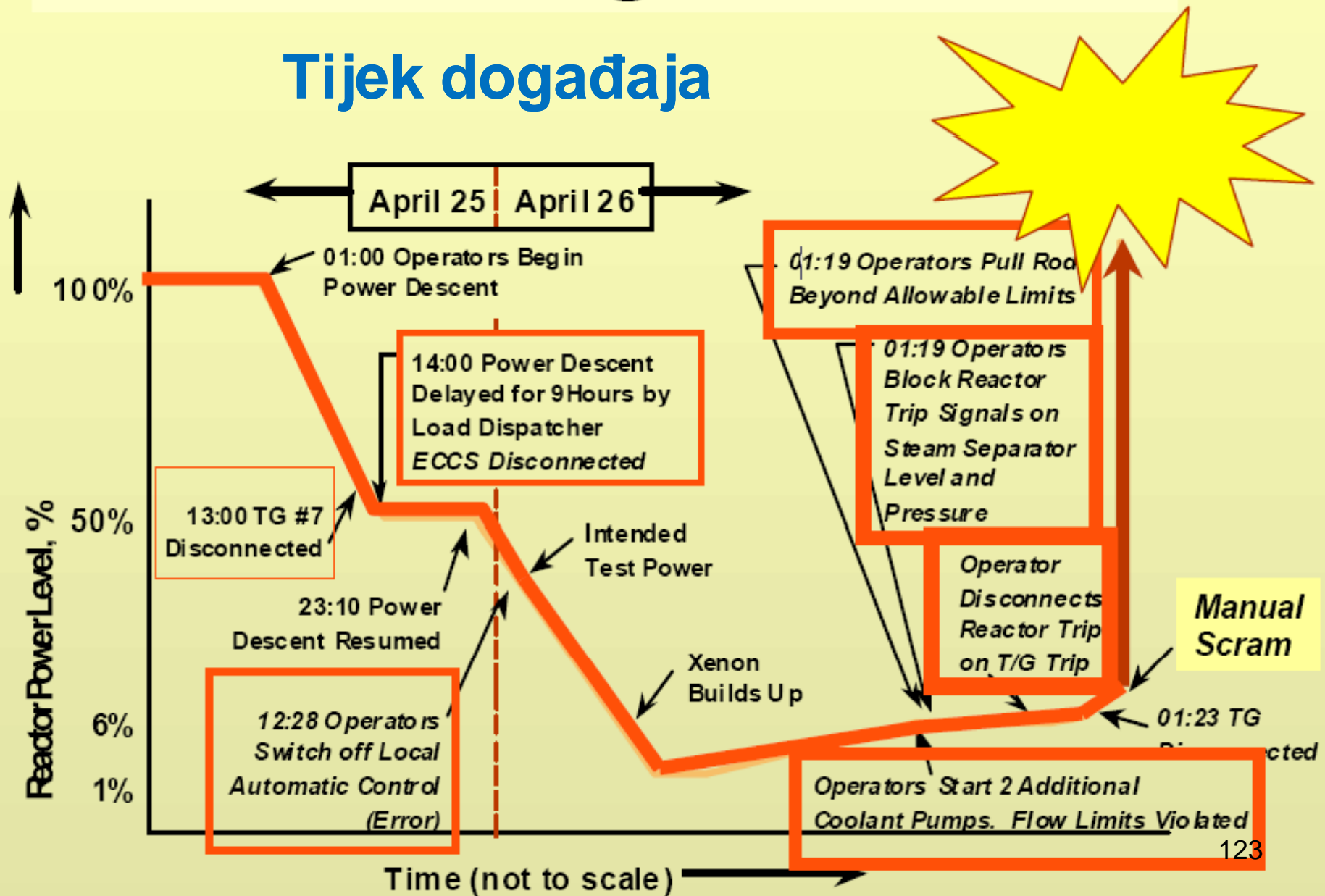

# Posljedice razaranja

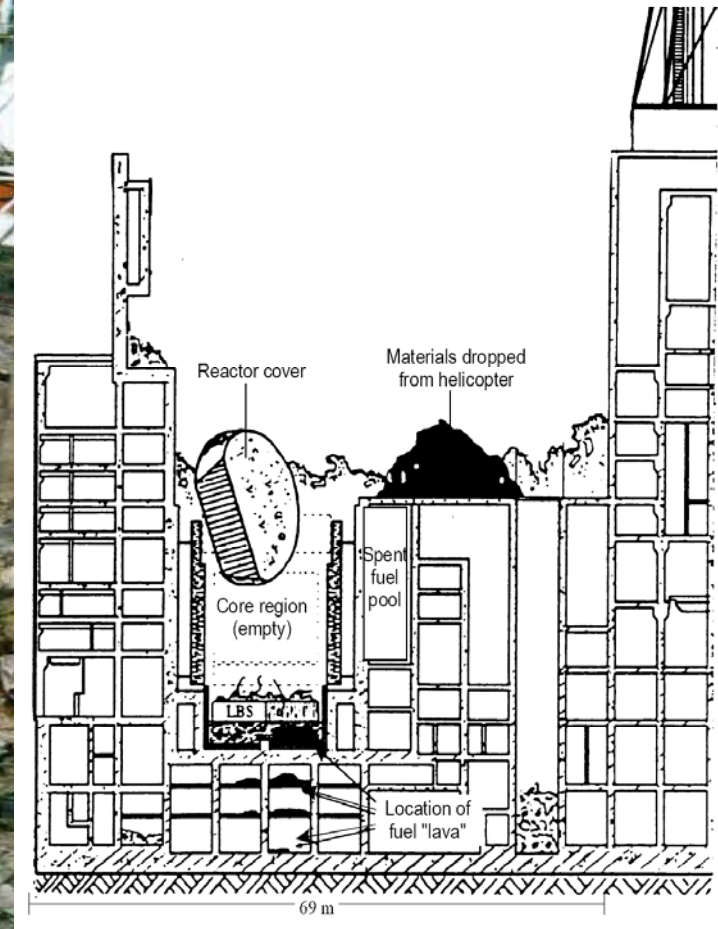

# Nesreća u NE Černobil - uzroci

- primarni uzrok (ljudska pogreška) - serija narušavanja instrukcija i operativnih procedura
- sekundarni uzrok (pozitivni koeficijent reaktivnosti i ostali nedostaci izvedbe elektrane)

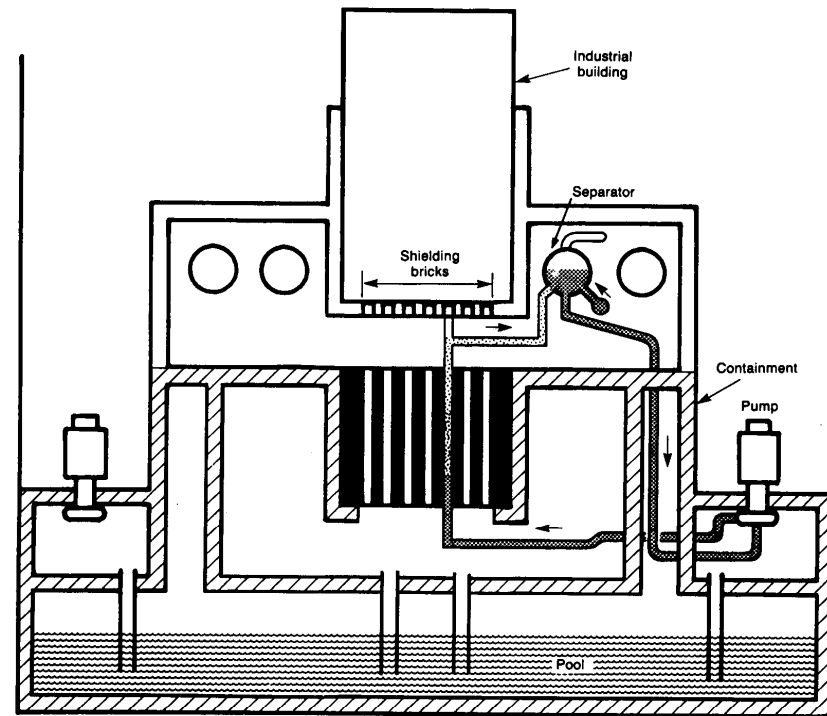
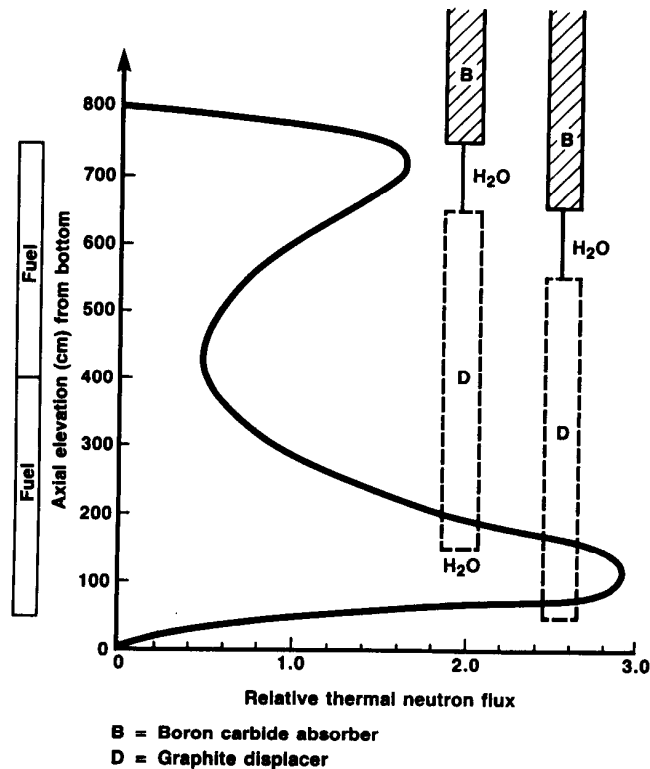

Figure 5 Axial flux distribution preceding accident.

# Nesreća u NE Černobilj - posljedice

- 31 žrtva neposredno nakon nesreće
- 134 su liječena od posljedica akutnog rđijacijskog sindroma
- Prema IAEA dokumentu INSAG-1 može se računati sa 170 dodatnih smrtnih slučajeva od raka
- procijenjeno povećanje rizika od smrtnosti zbog raka stanovništva zemalja zahvaćenim radioaktivnim oblakom varira od 0,03 % do 0,15 % u odnosu na neozračenu populaciju
- nesreća je imala ogroman negativan utjecaj na razvoj nuklearne energetike, iako RBMK nije relevantan za današnju nuklearnu energetiku



# Chernobyl Accident Consequences

## Actual Health Consequences

<u>Population</u>	<u>Number</u>
• Early fatalities (non-radiation)	2 (immediate)
• Early fatalities (radiation)	28 (within 4 m)
• Late adult fatalities (radiation)	19 (as of 9/05)
• Late child fatalities (radiation)	9* (as of 9/05)
• Clinical psychological effects	~ 5,000,000

---

\*All thyroid cancer deaths in population of 4000 identified and treated cases.

# Utjecaj na zdravlje - NGO

- 31 neposredna žrtva
- Približno 2500 dodatnih smrti vezano za akcident
- Značajan porast raka štitne žljezde
- Učestalost raka štitne žljezde u populaciji do 15 godina povećana od 4 do 6 u milion stanovnika (1981-1985) na 45 u milion stanovnika (na nivou cijele Ukrajine) u razdoblju 1986 do 1997
- 64% slučajeva zabilježeno u najzagađenijim područjima.



## Nezdravstveni utjecaj na lokalnu zajednicu

- 116,000 ljudi evakuirano od 1990 do 1995 i 210,000 relocirano.
- Promjene u osnovnoj infrastrukturi
- Manjak električne energije
- Poljoprivredne aktivnosti znatno smanjene s direktnim utjecajem na prihod stanovništva.

# Utjecaj na okoliš

- Radioaktivna kontaminacija u dobrom dijelu Europe, u konačnici gotovo cijela sjeverna hemisfera.
- U lokalnom ekosustavu (10 km radius) promjene na stablima, smrt malih sisavaca.
- Okoliš se oporavlja ali na duge staze mogući su genetski efekti.

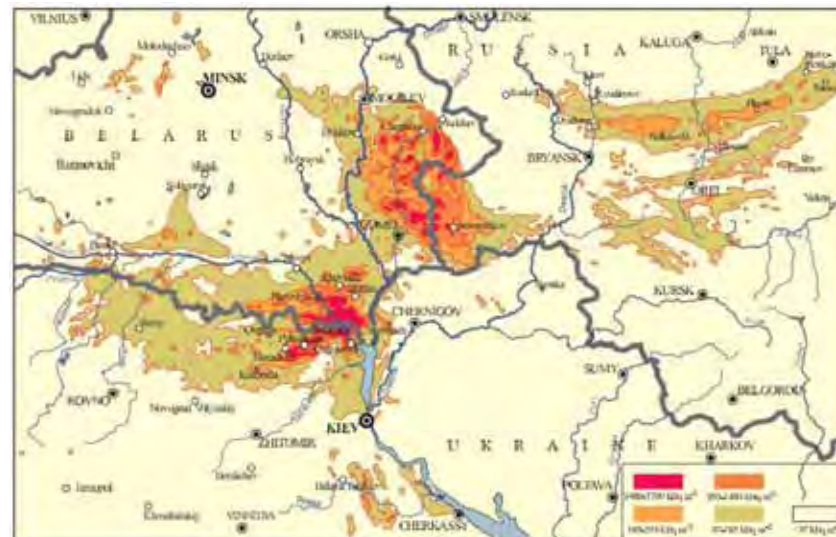

Cs-137

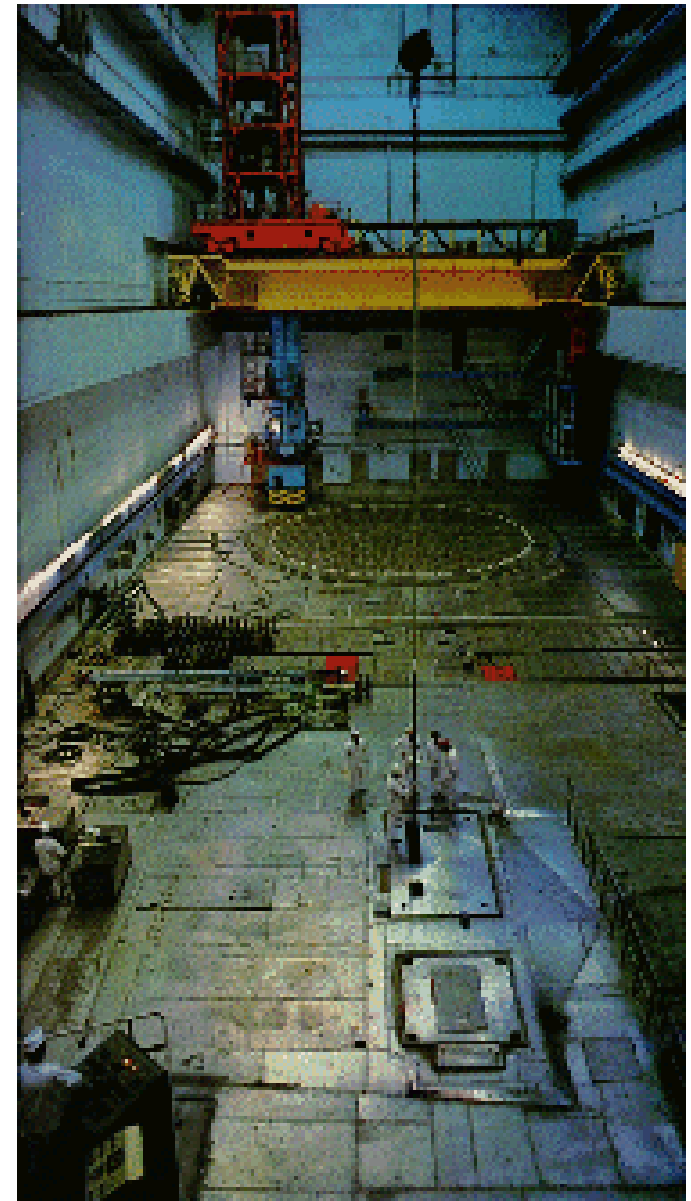



# Černobilski eko-paradoks



# A Close Call -- Davis-Besse

- PWR, 873 MWe, started up in 1977
- Boric acid clogged containment air cooler in 1999
- Containment radiation monitor showed contamination and clogging in May 1999
- Significant head corrosion began in 1998 or earlier
- Five control rod penetration nozzles were cracked, 3 penetrated nozzle wall
- Large cavity in vessel wall, sealed only by vessel liner
- NRC has placed 27 PWR plants in the 'high risk' category for vessel corrosion - some in vessel bottom penetrations

# Davis-Besse Head Corrosion Location

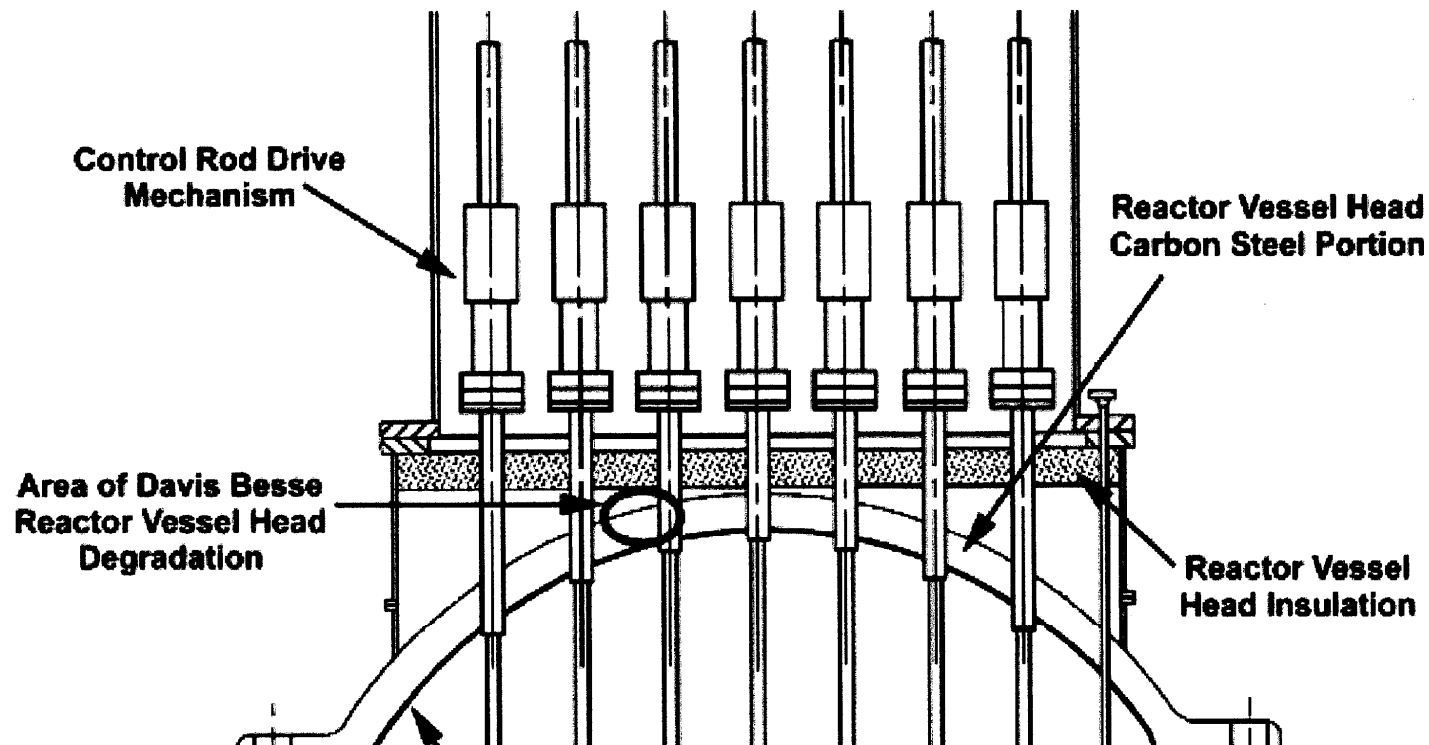



# DB - A Hole in the Head

Stainless steel liner bulged, but did not fail





# Međunarodna skala nuklearnih događaja

Promptna informacija o značaju događaja za sigurnost

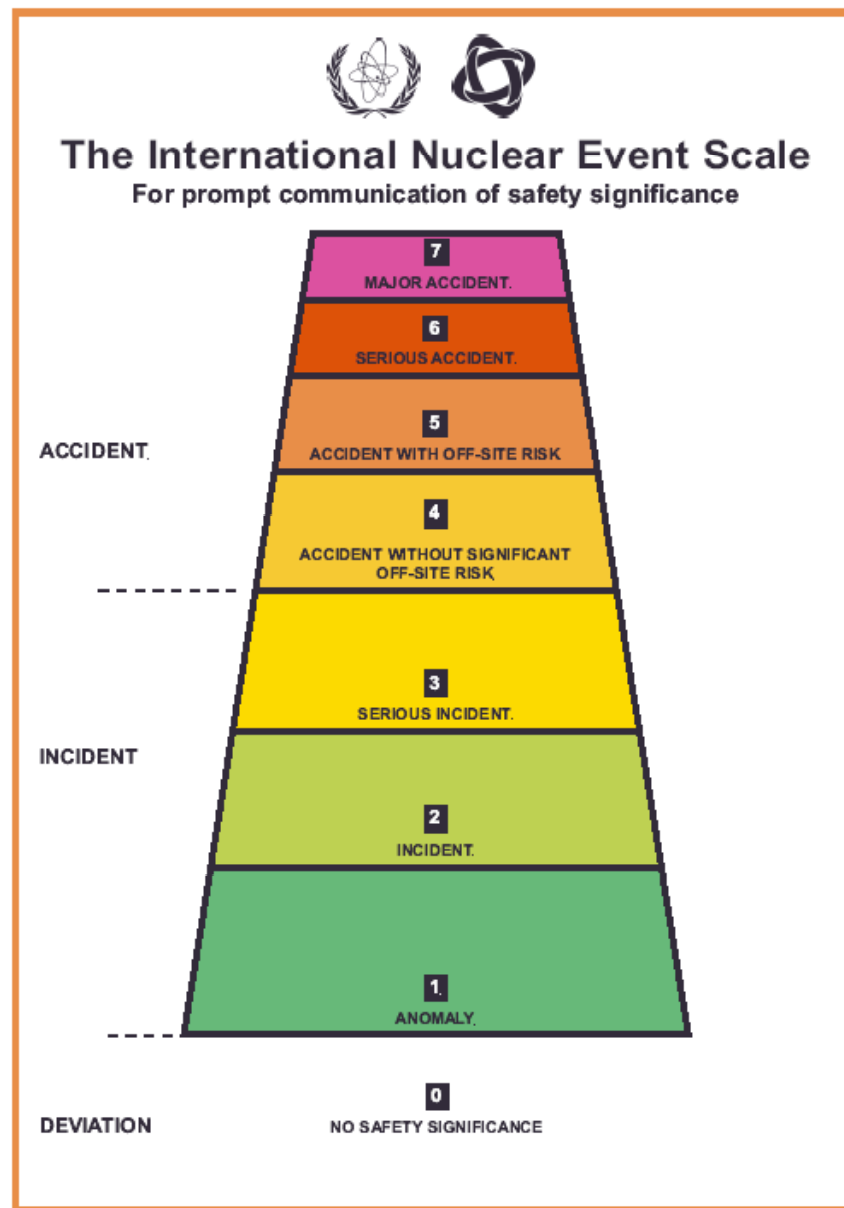



# Basic Structure of the Scale

*(Criteria given in matrix are broad indicators only)  
Detailed definitions are provided in the INES User's Manual*

	CRITERIA OR SAFETY ATTRIBUTES		
	OFF-SITE IMPACT	ON-SITE IMPACT	DEFENCE IN DEPTH DEGRADATION
7 MAJOR ACCIDENT	MAJOR RELEASE: WIDESPREAD HEALTH AND ENVIRONMENTAL EFFECTS		
6 SERIOUS ACCIDENT	SIGNIFICANT RELEASE: LIKELY TO REQUIRE FULL IMPLEMENTATION OF PLANNED COUNTERMEASURES		
5 ACCIDENT WITH OFF-SITE RISK	LIMITED RELEASE: LIKELY TO REQUIRE PARTIAL IMPLEMENTATION OF PLANNED COUNTERMEASURES	SEVERE DAMAGE TO REACTOR CORE/RADIOLOGICAL BARRIERS	
4 ACCIDENT WITHOUT SIGNIFICANT OFF-SITE RISK	MINOR RELEASE: PUBLIC EXPOSURE OF THE ORDER OF PRESCRIBED LIMITS	SIGNIFICANT DAMAGE TO REACTOR CORE/RADIOLOGICAL BARRIERS/FATAL EXPOSURE OF A WORKER	

# INES

4 ACCIDENT WITHOUT SIGNIFICANT OFF-SITE RISK	MINOR RELEASE: PUBLIC EXPOSURE OF THE ORDER OF PRESCRIBED LIMITS	SIGNIFICANT DAMAGE TO REACTOR CORE/RADIOLOGICAL BARRIERS/FATAL EXPOSURE OF A WORKER	
3 SERIOUS INCIDENT	VERY SMALL RELEASE: PUBLIC EXPOSURE AT A FRACTION OF PRESCRIBED LIMITS	SEVERE SPREAD OF CONTAMINATION/ACUTE HEALTH EFFECTS TO A WORKER	NEAR ACCIDENT NO SAFETY LAYERS REMAINING
2 INCIDENT		SIGNIFICANT SPREAD OF CONTAMINATION/ OVEREXPOSURE OF A WORKER	INCIDENTS WITH SIGNIFICANT FAILURES IN SAFETY PROVISIONS
1 ANOMALY			ANOMALY BEYOND THE AUTHORIZED OPERATING REGIME
0 DEVIATION	NO	SAFETY	SIGNIFICANCE
OUT OF SCALE EVENT	NO SAFETY RELEVANCE		

# Istrošeno gorivo

## **Privremeno skladištenje istrošenog goriva**

- Skladištenje istrošenog goriva od napuštanja reaktora do konačnog odlaganja
- Mokro (bazen za istrošeno gorivo)
- Suho (posebni spremnici nakon inicijalnog hlađenja)
- Daju vremena za kvalitetan izbor konačnog odlagališta
- Omogućuju preradu istrošenog goriva

# Nuclear Fuel Cycle & Waste Generation

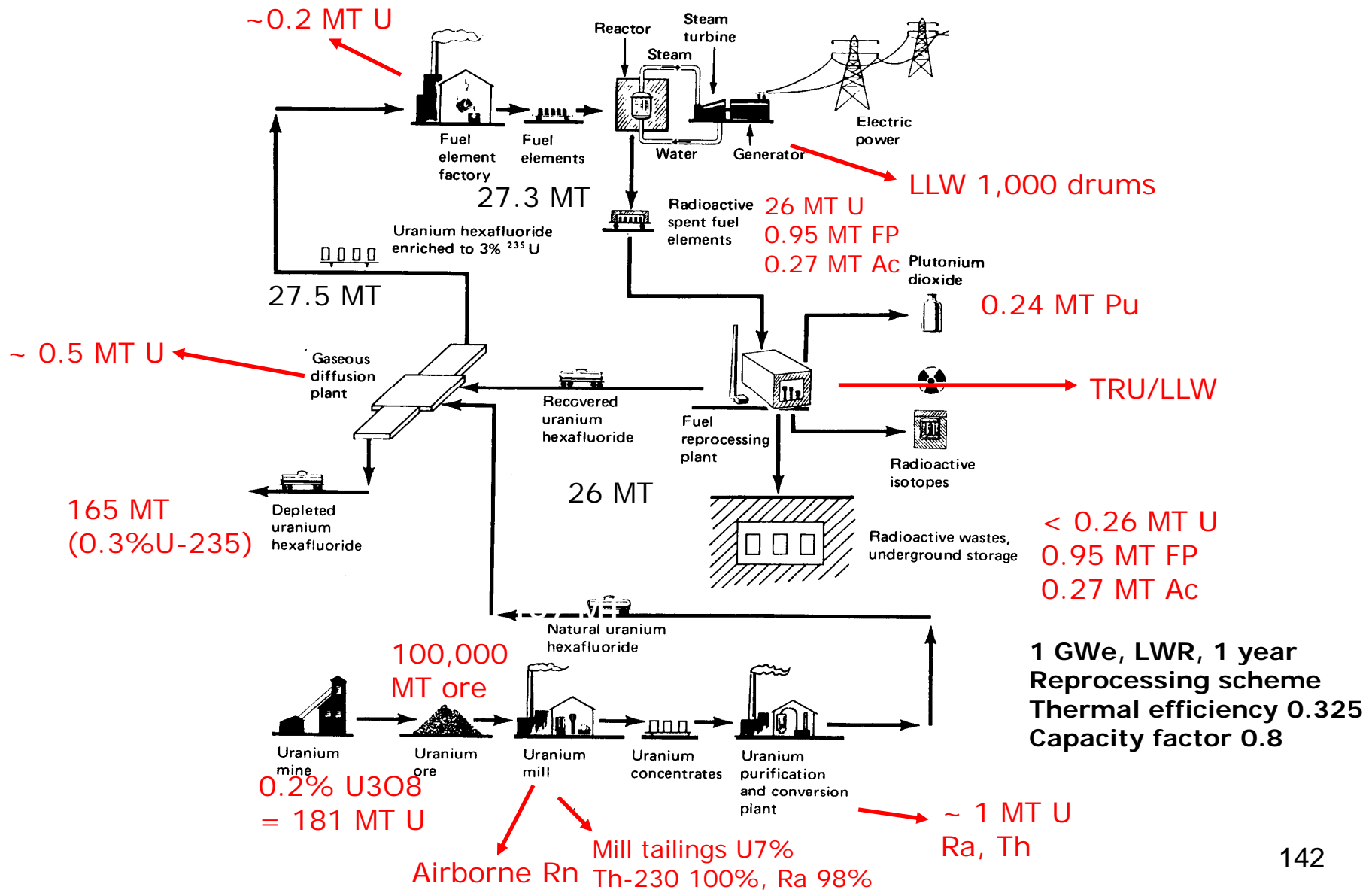

## Bazen za istrošeno gorivo

- Trenutno obično primaju istrošeno gorivo proizvedeno za cijeli životni vijek elektrane
- Osiguravaju štit od zračenja i hlađenje
- Nadzor kritičnosti
- Odgovarajuća zgrada mora garantirati mehaničku zaštitu i kontrolirani pristup
- Potrebno aktivno hlađenje

# Bazen za istošeno gorivo

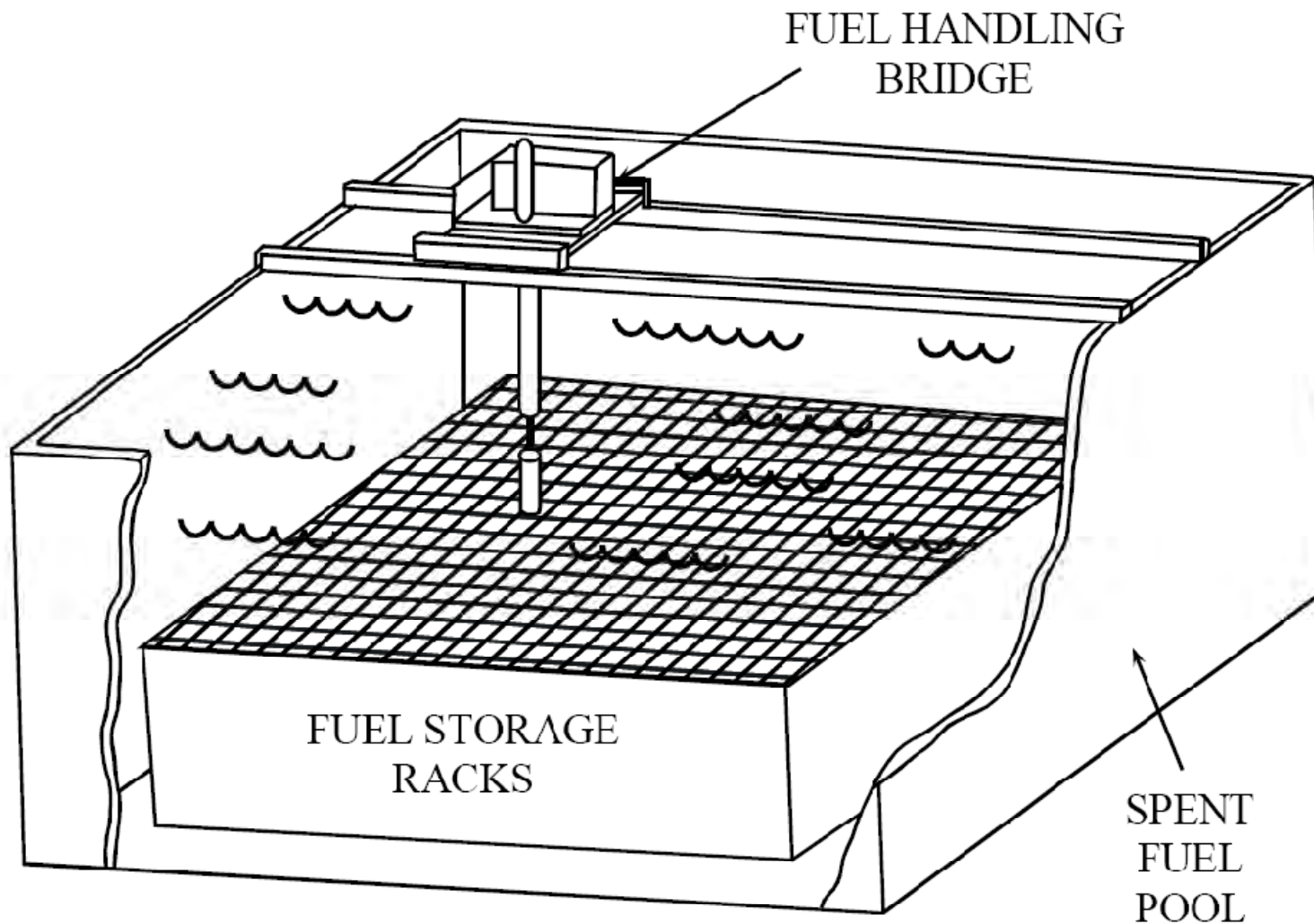



# Privremeno suho skladištenje istrošenog goriva

- Lokacija (elektrana, centralno skladištenje)
- Debeli metalni štit čini zračenje neškodljivim za ljudsko zdravlje
- Hermetički zatvoreni
- Otporni na sva prirodna i ljudska djelovanja
- Ekonomično rješenje
- Trajnost oko 100 godina

# Privremeno suho skladištenje istrošenog goriva

Spremnik za suho skladištenje

Transportni spremnik

Masa oko 200 t

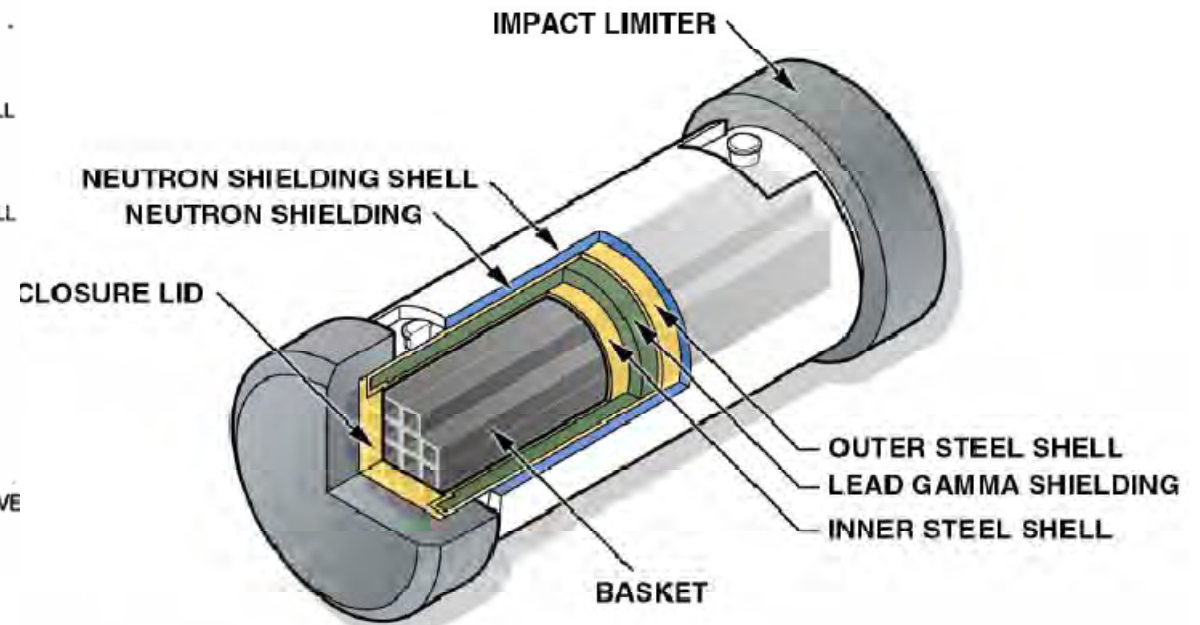
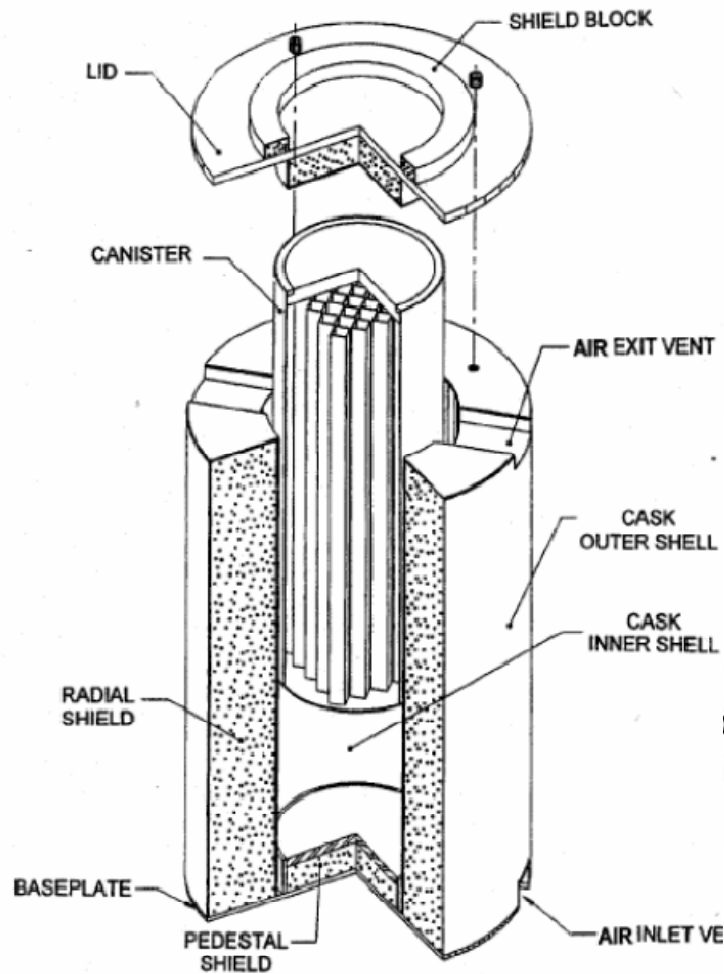

# Privremeno suho skladištenje istrošenog goriva

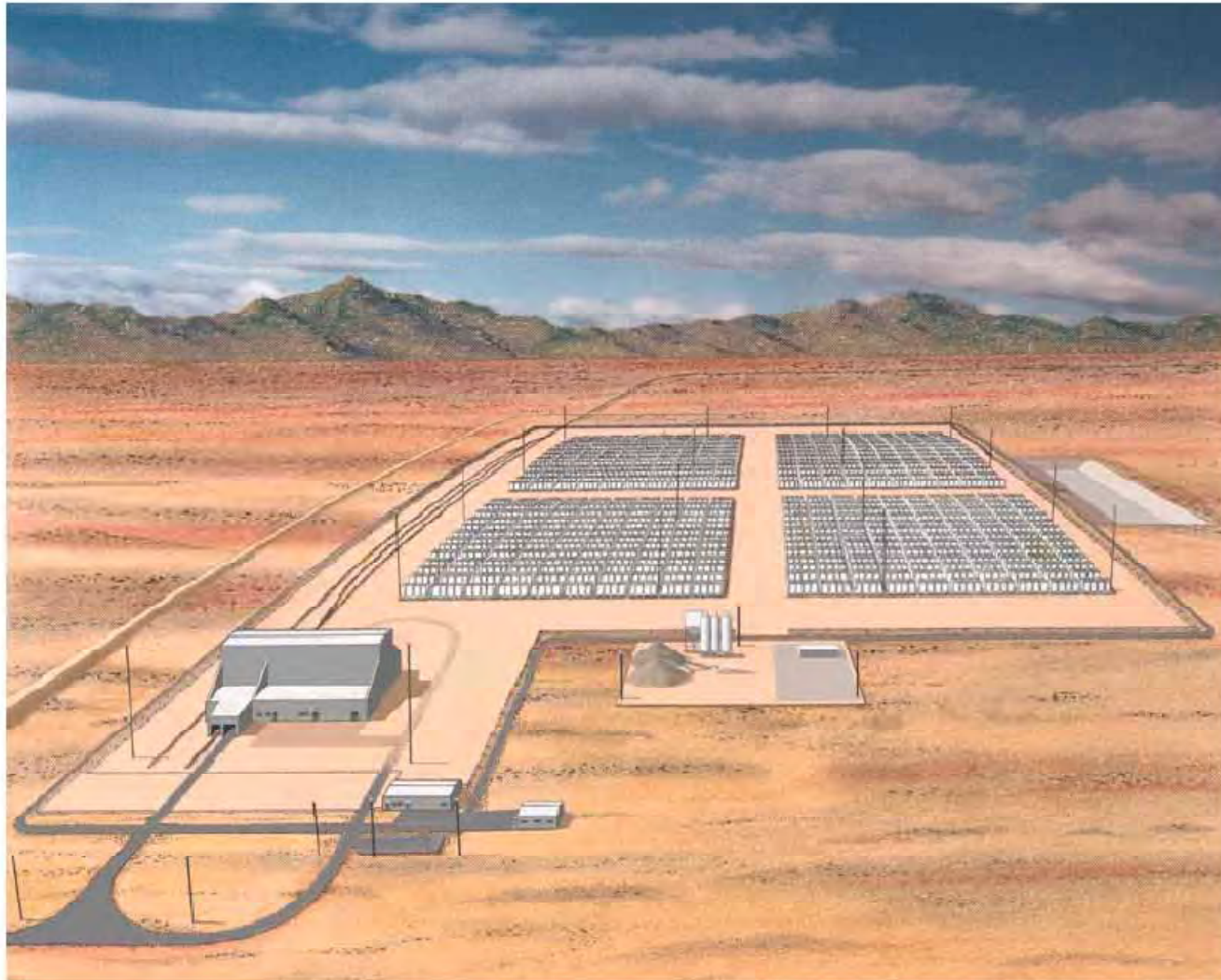

# Trajno odlaganje visokoaktivnog otpada

- Spominje se kao najveći problem nuklearne energetike
- Količine su razumne za spremanje
- Direktno zračenje i hlađenje manji problem
- Potrebno onemogućiti ispuštanje radioaktivnosti u ekosustav za dugi niz godina
- Kombinacija prirodnih i inženjerskih barijera
- Tehnički izvedivo ali nema previše uspješnih primjera
- Transmutacija posebno povoljna (količina i trajnost)



# Sustav prirodnih barijera za širenje radioaktivnosti

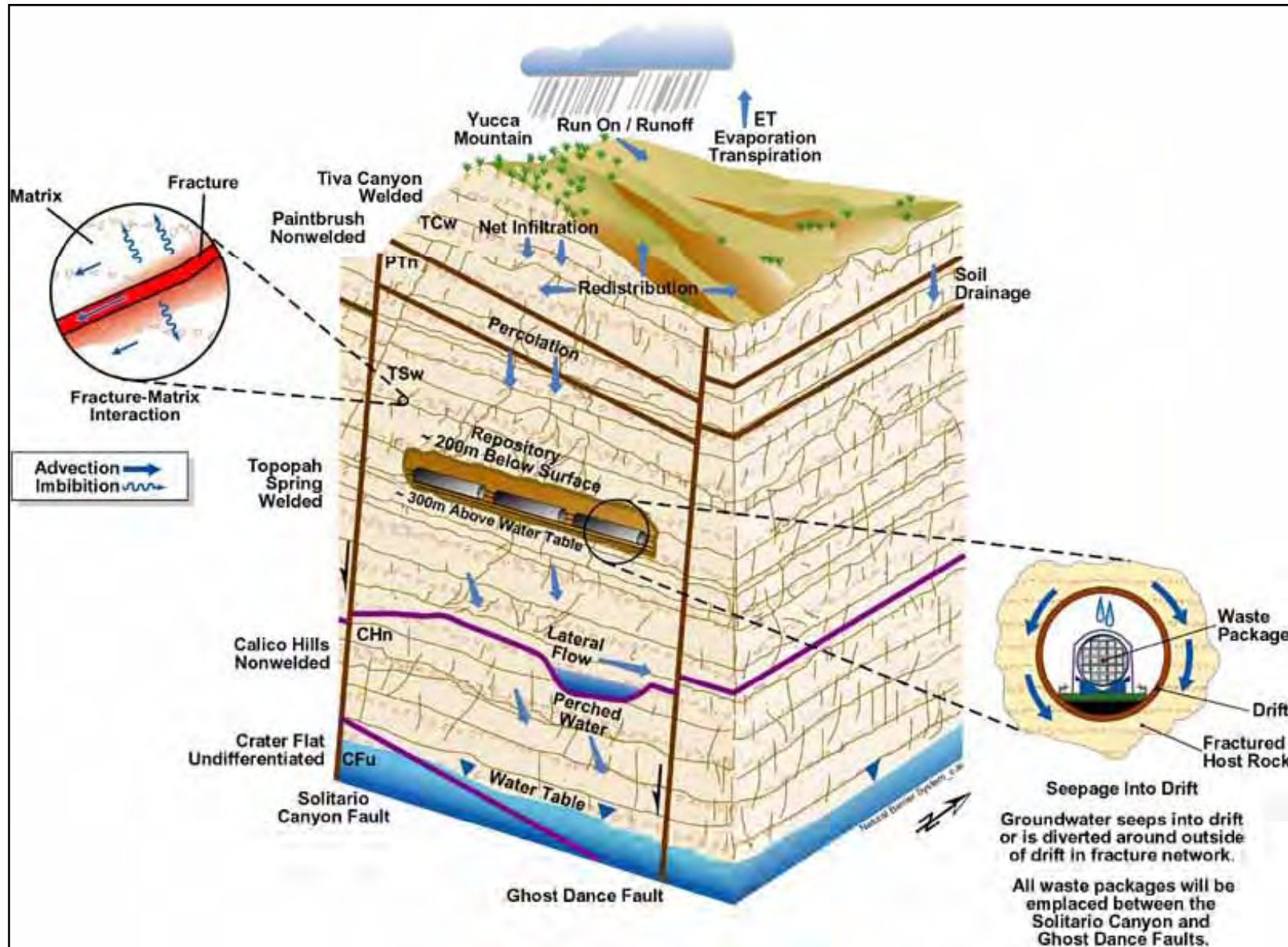

# Sustav inženjerskih barijera za širenje radioaktivnosti

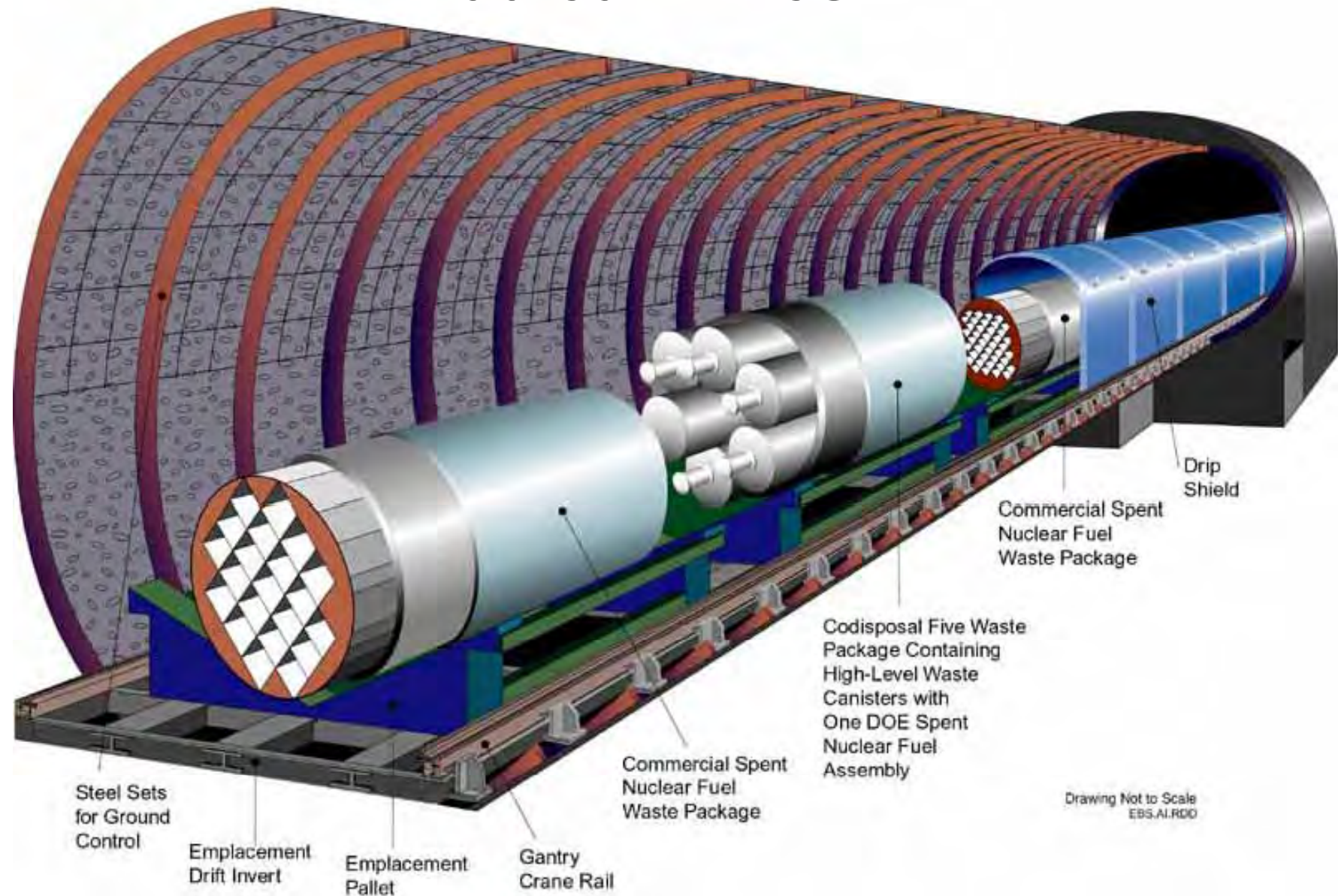

# Nuklearni gorivni ciklus



# Primjer zatvorenog gorivnog ciklusa

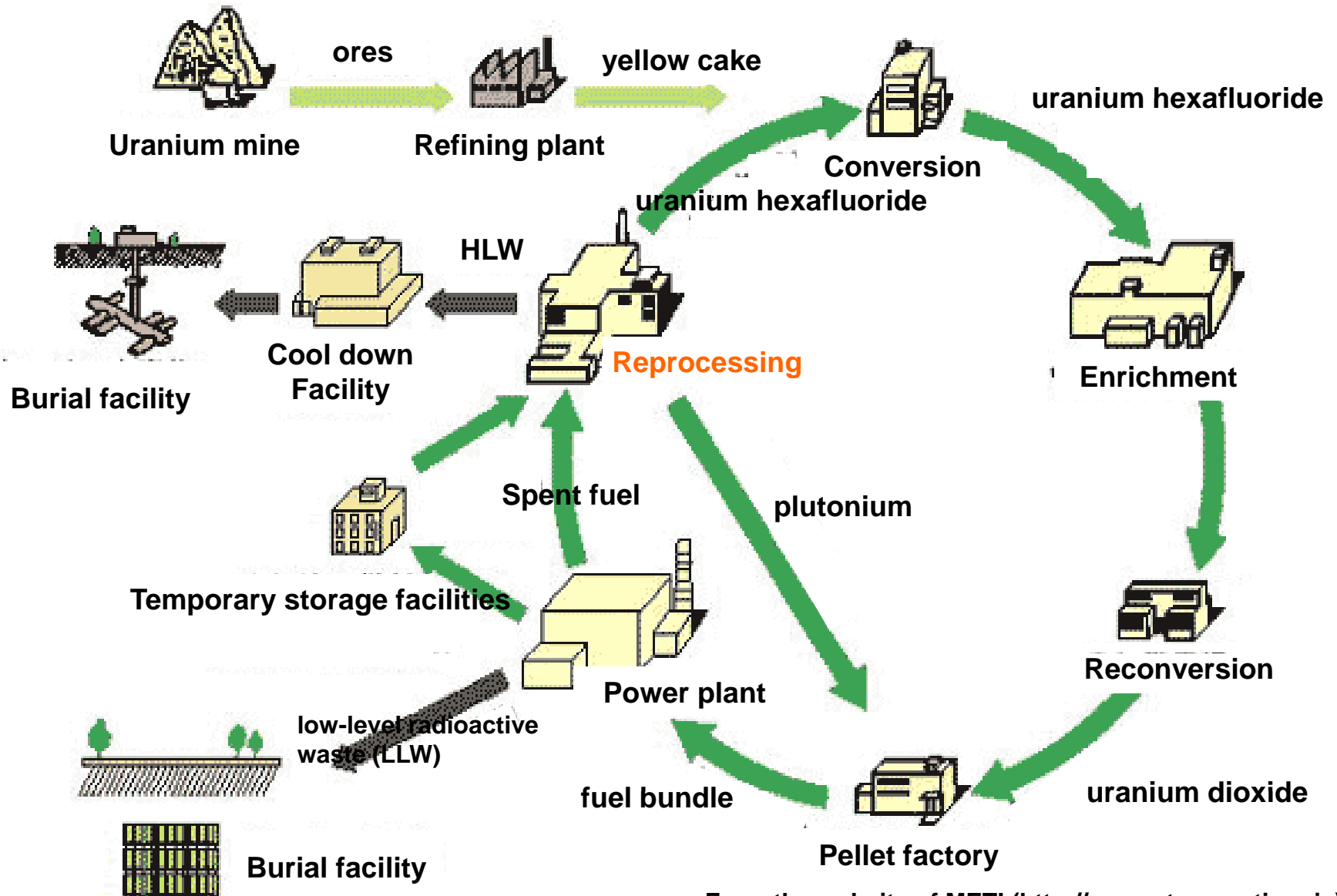

From the website of METI (<http://www.atom.meti.go.jp>)



## Kumulativni potrošak prirodnog urana u ovisnosti o strategiji razvoja nuklearne energetike

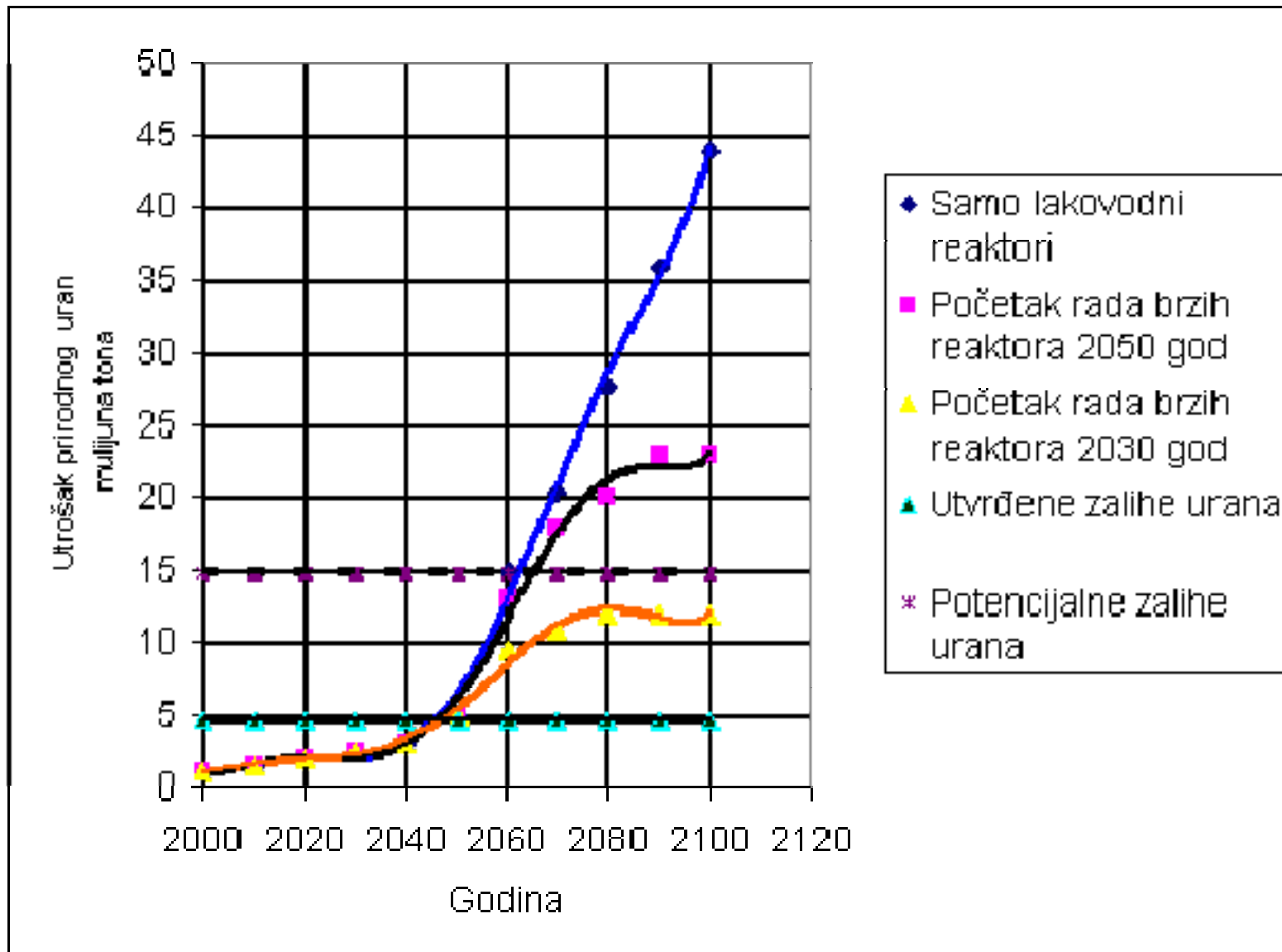

# Svjetske rezerve urana (stanje početak 2003)

*Secure*

< 80\$/kgU

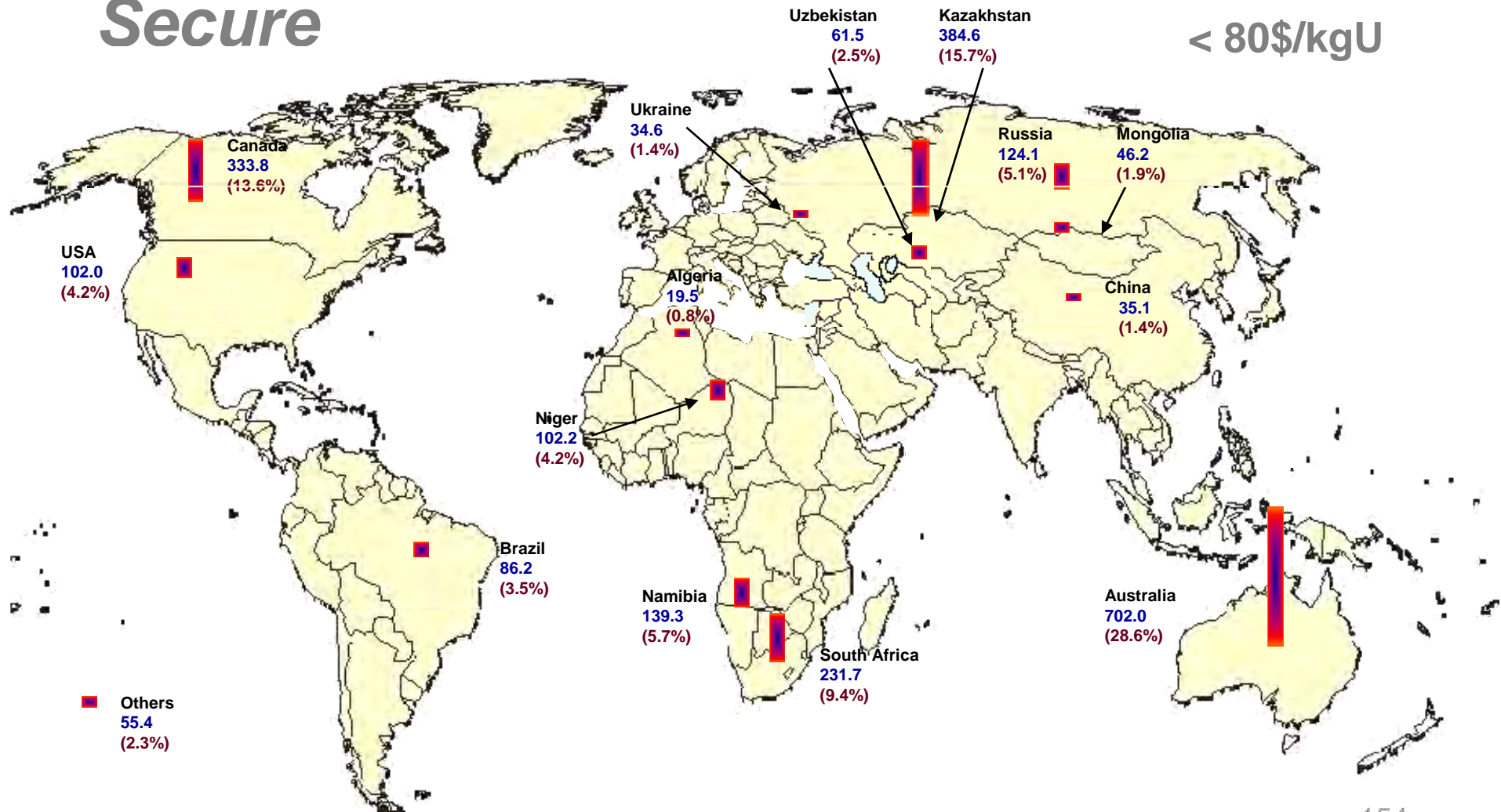

# Rezerve urana

- **Sadašnjost ~ 14.4 MT**
  - **Sigurne rezerve** **3.2 MT**
  - **Procijenjene dodatne I** **1.4 MT**
  - **Procijenjene dodatne II** **2.3 MT**
  - **Spekulativne rezerve** **7.5 MT**

**Potrošnja ~ 0.06 - 0.07 MT/y**
- **Budućnost**
  - **Konvencionalne rezerve ~ 200 god**
  - **Nekonvencionalne rezerve**
    - **Fosfati ~ 22 MT**
    - **Morska voda ~ 4000 MT**
  - **Oplodne tehnologije mogu povećati iskoristivost goriva 50 do 70 puta (zatvoreni ciklusi)**

# Concept Description

- *Sodium-cooled fast spectrum reactors using a closed fuel cycle with full actinide recycle*
- *Missions: Actinide management and electricity production*
  - » *Reduces physical demands on repositories*
  - » *Utilizes the entire natural resource of fissionable material*
- *Estimated Deployment Date: 2020*

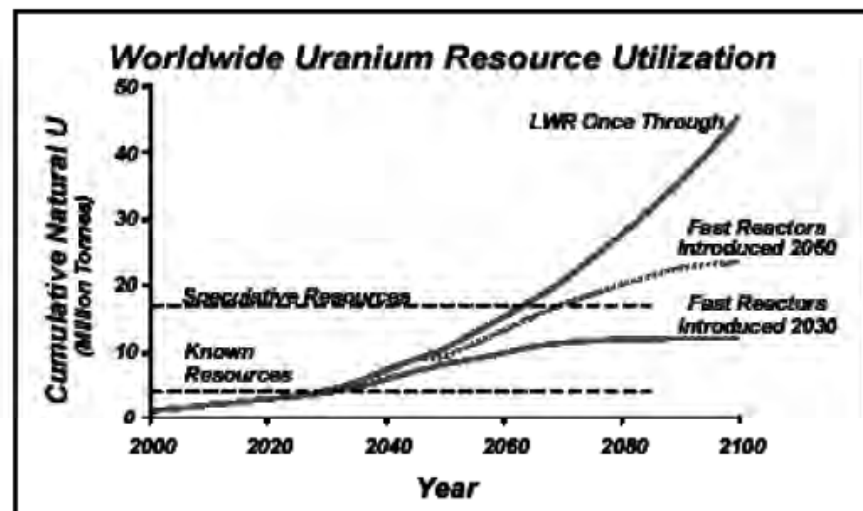
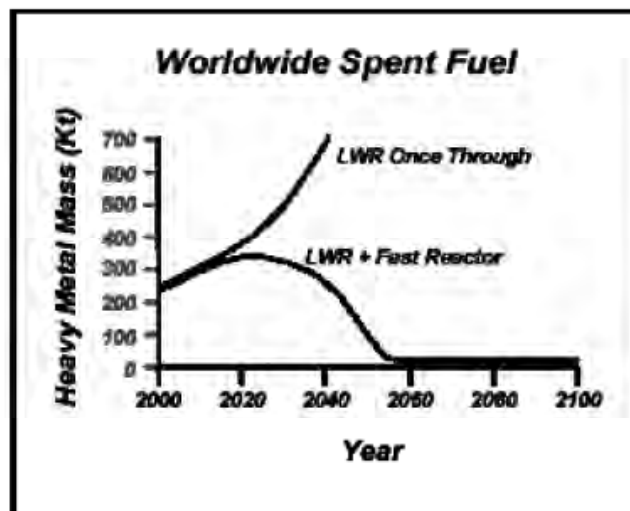

# Transmutation System Approach

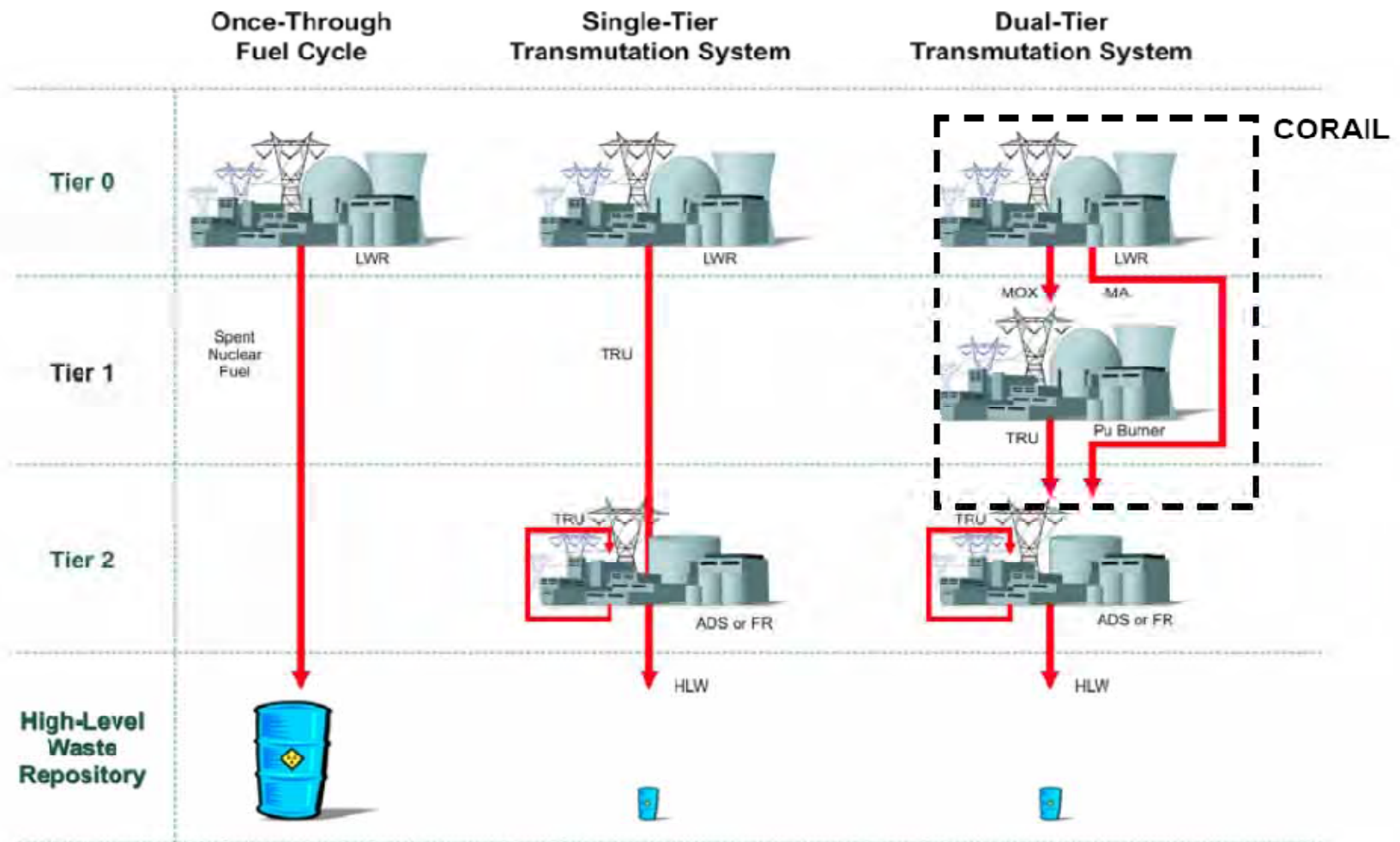

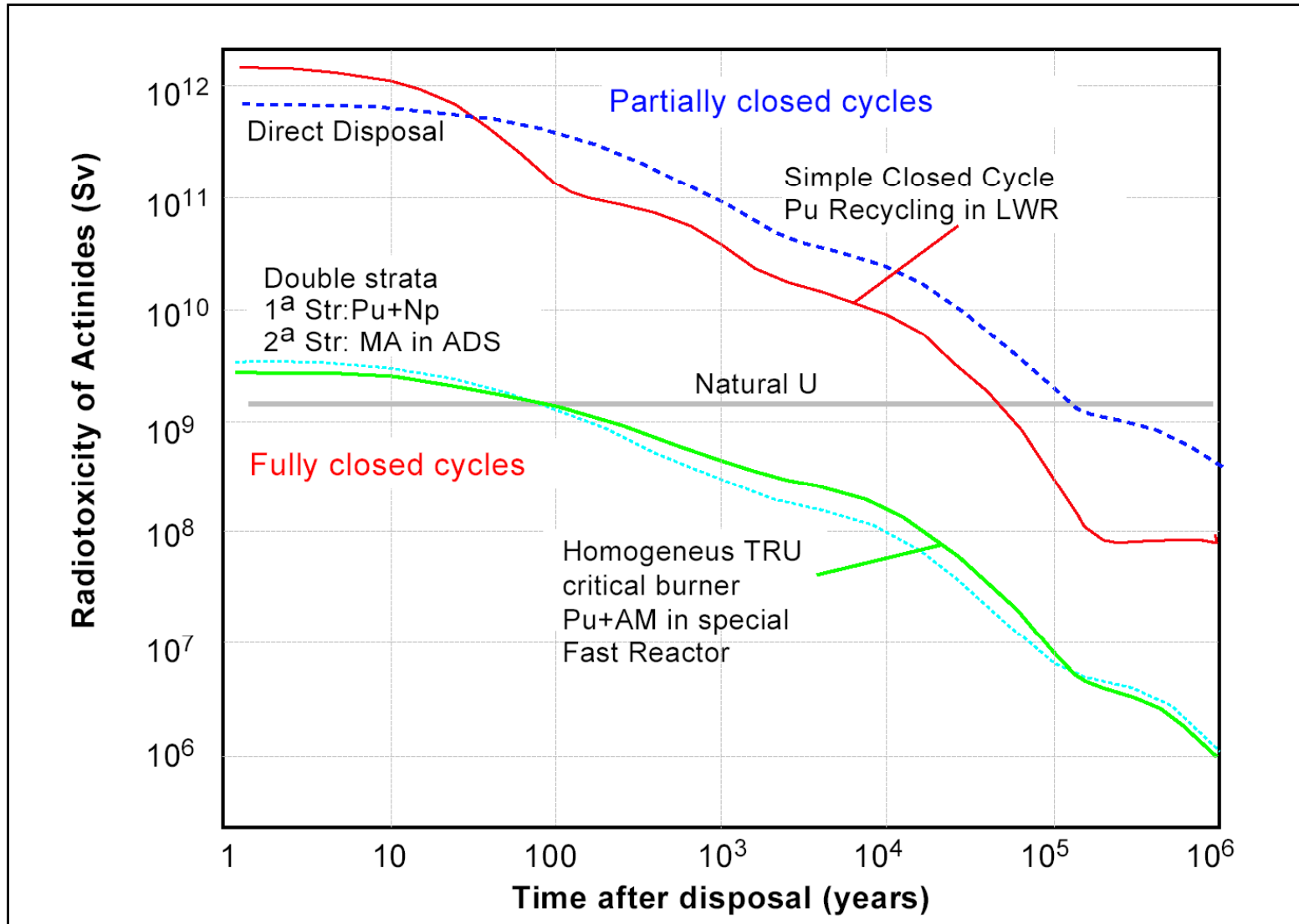

# Zračenje

# Zašto je zračenje štetno?

- Zračenje je energija u obliku čestica ili valova
- Može biti ionizirajuće i neionizirajuće
- Zračenje deponira male količine energije u materijalu:
  - Ionizira i mijenja atome
  - Oštećenje ćelija i DNK izaziva mutacije i rak
  - Slični efekti su posljedica izlaganja nekim kemikalijama
  - Većina oštećenja je izazvana produkcijom iona



# Ionizacija

## Formiranje nabijenog atoma

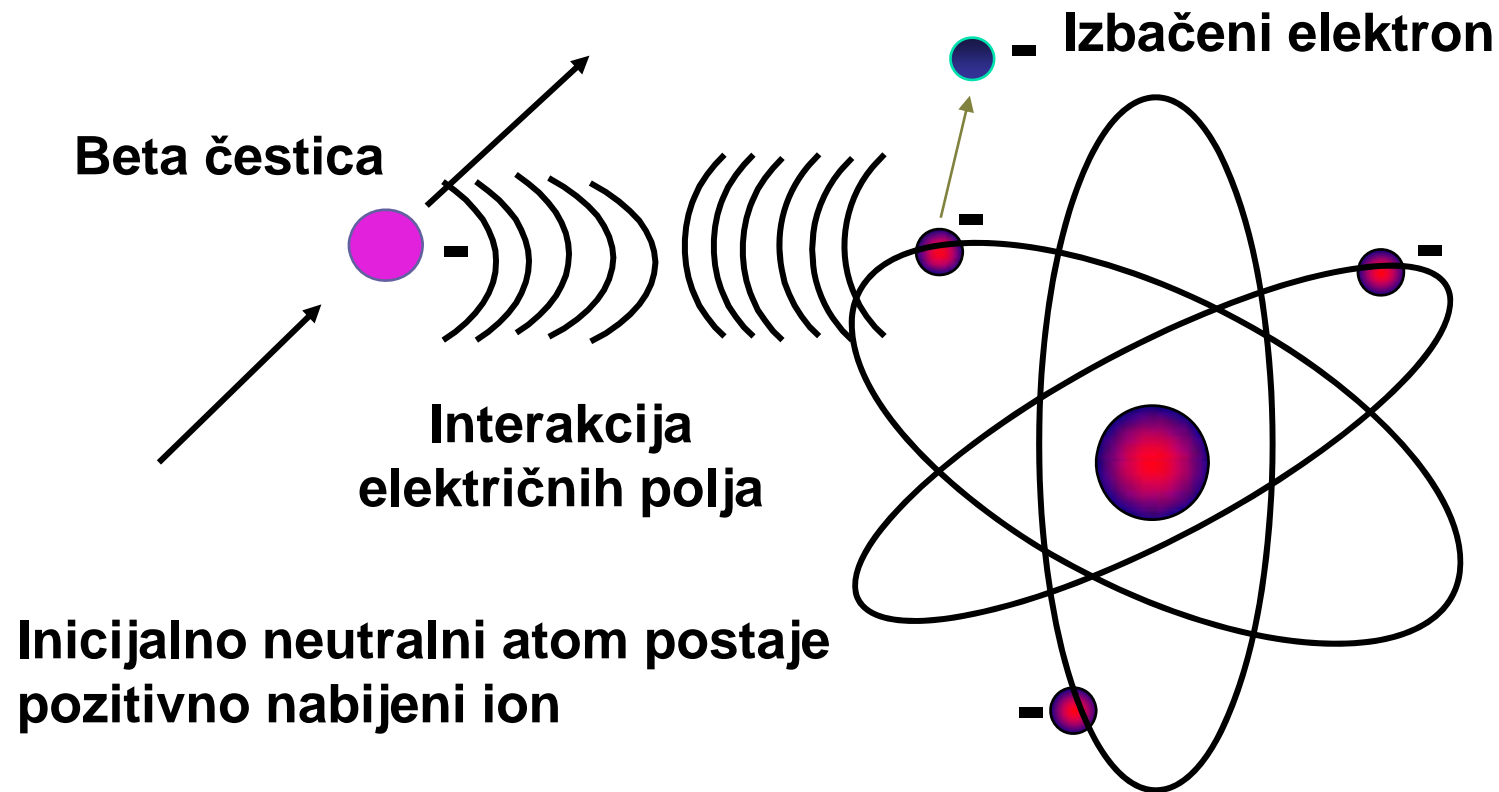

# Zaštita od zračenja

- Može biti jednostavna i složena
- Vanjski i unutarnji izvor
- Osnovni principi:
  - Ograniči izloženost (vrijeme)
  - Povećaj udaljenost od izvora zračenja
  - Upotrijebi štit od zračenja
- Jednostavna zaštita za vanjsku izloženost
- Za izvor: smanjiti volumen, imobilizirati, oklopiti

# Rizik i posljedice

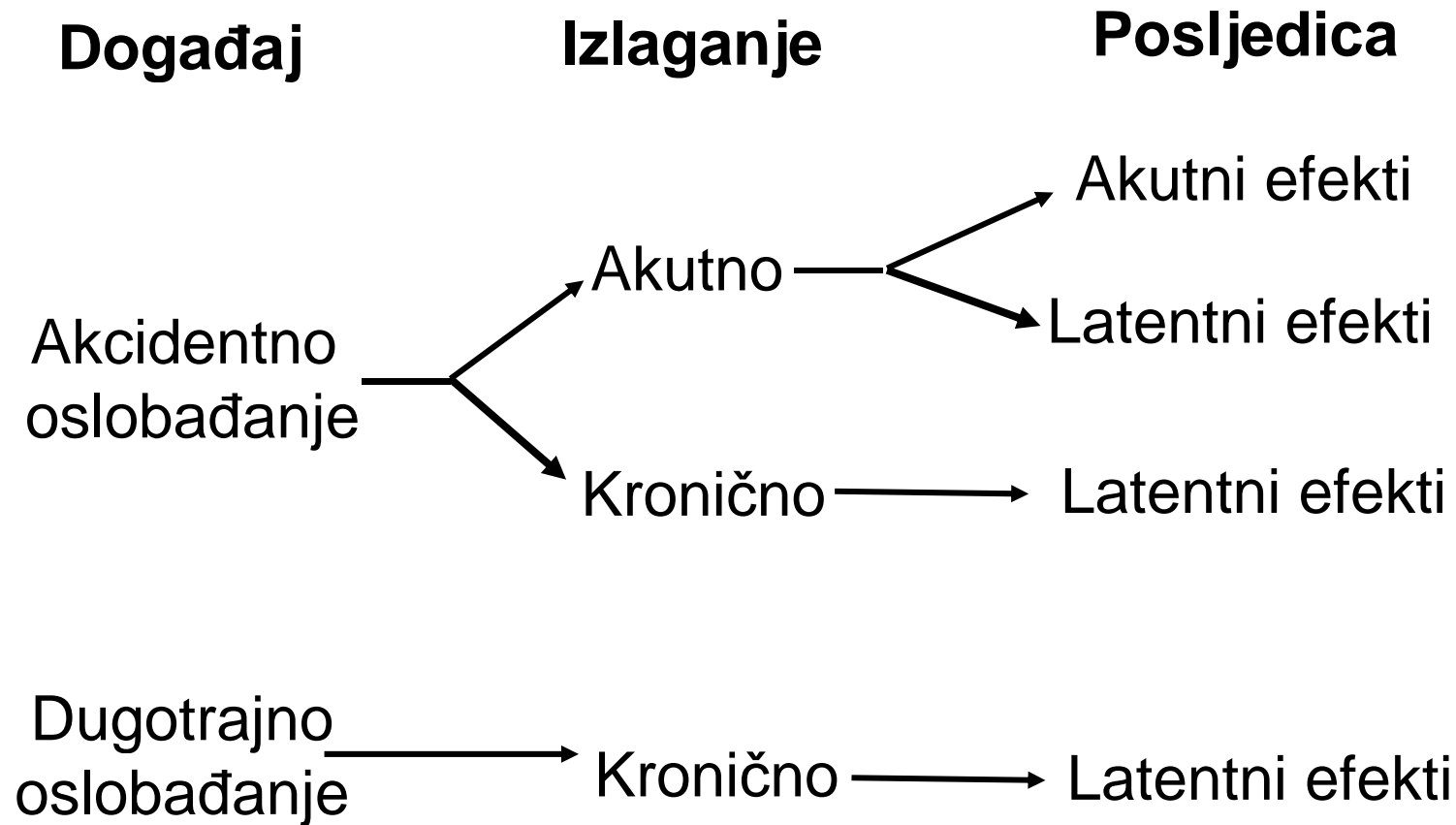

# Izlaganje zračenju

- Akutno – velike doze primljene unutar krećeg vremena
  - Akutni radijacijski sindrom
- Kronično – manje doze primljene unutar dužeg vremena (ćelije imaju vremena za oporavak)
  - Povećani rizik za rak (+0.07% po primljenom remu tijekom životnog vijeka, referentni rizik od raka 25%)
  - Genetski defekti
- Veza doza-efekt za akutne doze jasna
- Za male doze postoji više hipoteza

# Primljena doza i moguća posljedica

- Modeli se razlikuju po tome kako uzimaju u obzir rizik od malih doza

$$R(d) = \text{const} \times d^m$$

$m = 1$  linear

$m > 1$  sublinear

$m < 1$  supralinear

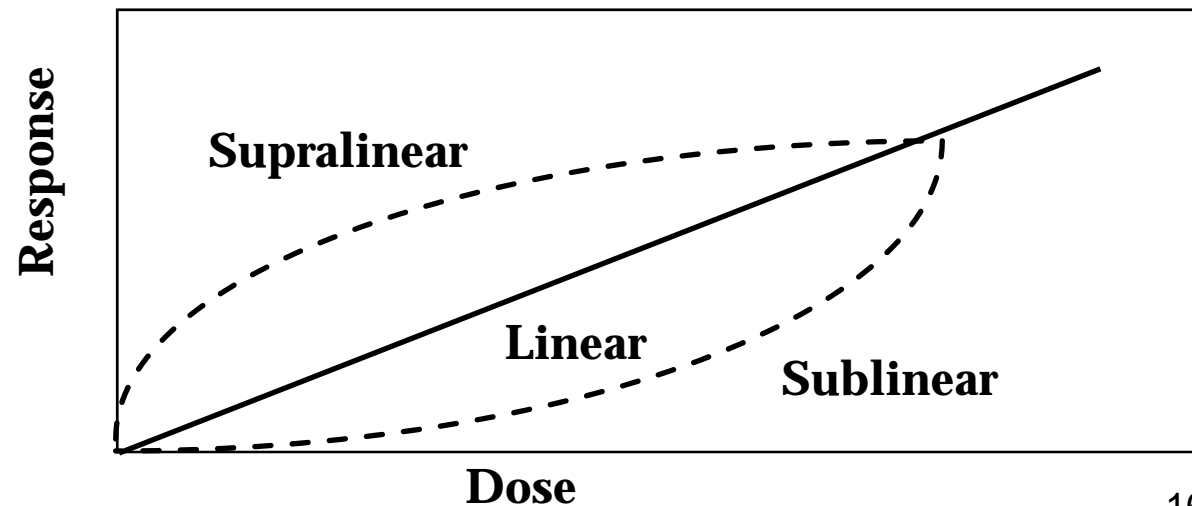

# DNK i zračenje

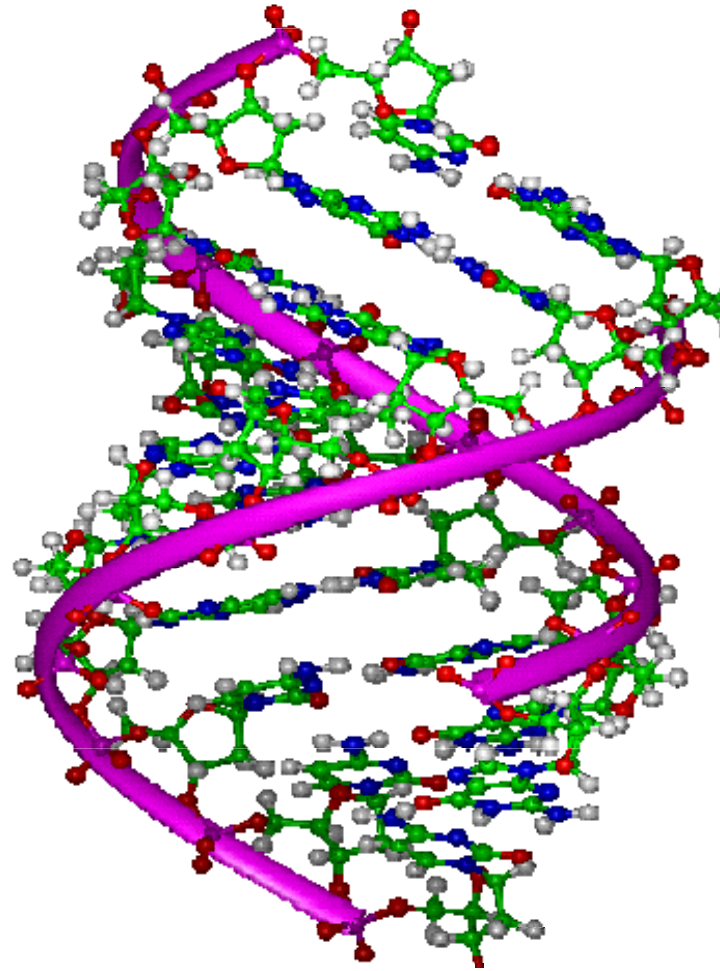

# Ionizirajuće zračenje na ćelijskom nivou

- Uzrokuje prekide u jednom ili oba DNK lanca;
- Uzrokuje formiranje slobodnih radikala

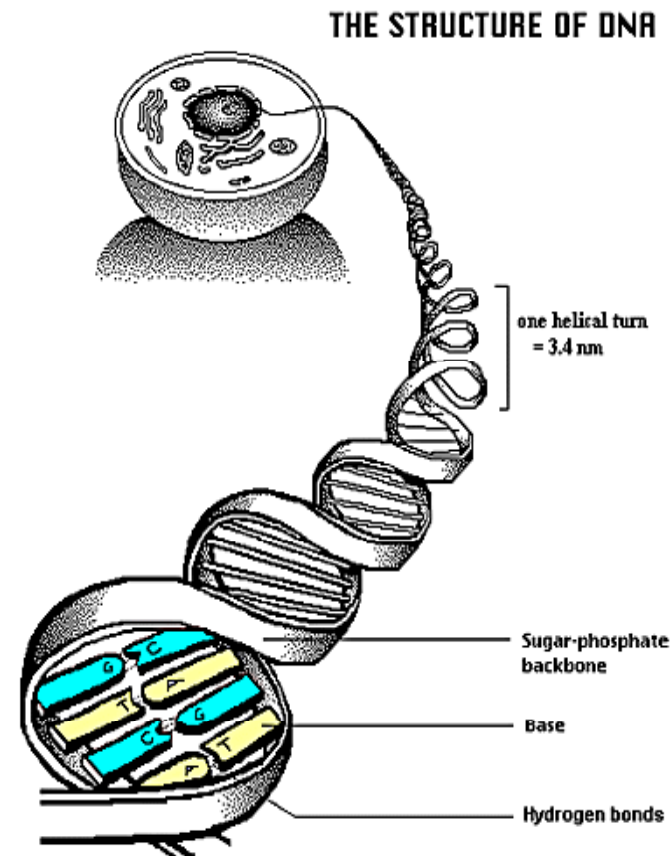

# Utjecaj na ćeliju

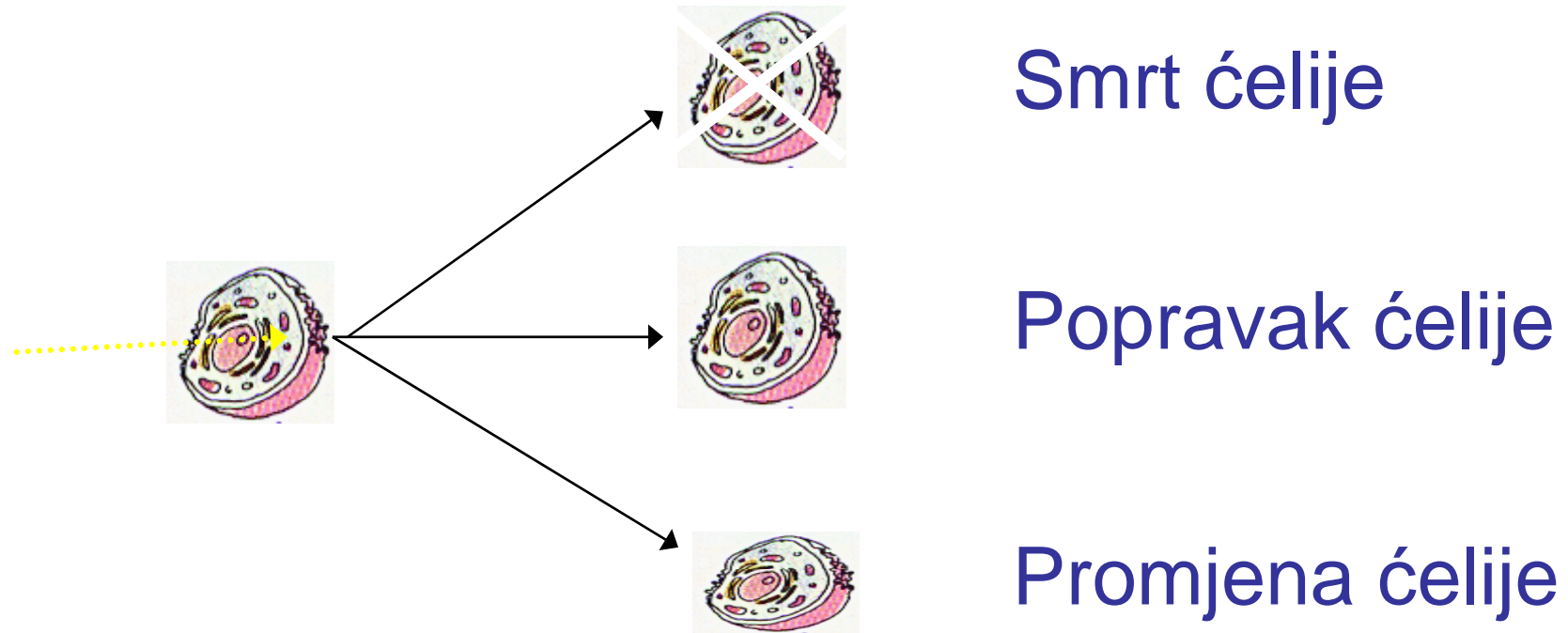

Da li je promjena dobra ili loša?



# Tijelo posjeduje mehanizme zaštite

- **DNK oštećenje može dovesti do disfunkcije ćelije ili smrti.**
- **U tijelu ima oko  $60 \cdot 10^{12}$  ćelija**
  - **Smatra se da svaka ćelija biva pogođena na neki način svakih 10 s, milioni DNK prekida po ćeliji svake godine.**
  - **Pozadinsko zračenje izaziva 5 do 10 DNK prekida po ćeliji svake godine.**
- **Tijelo posjeduje efikasne mehanizme popravke oštećenja DNK**
- **Ćelije koje se često dijele su osjetljivije na zračenje**

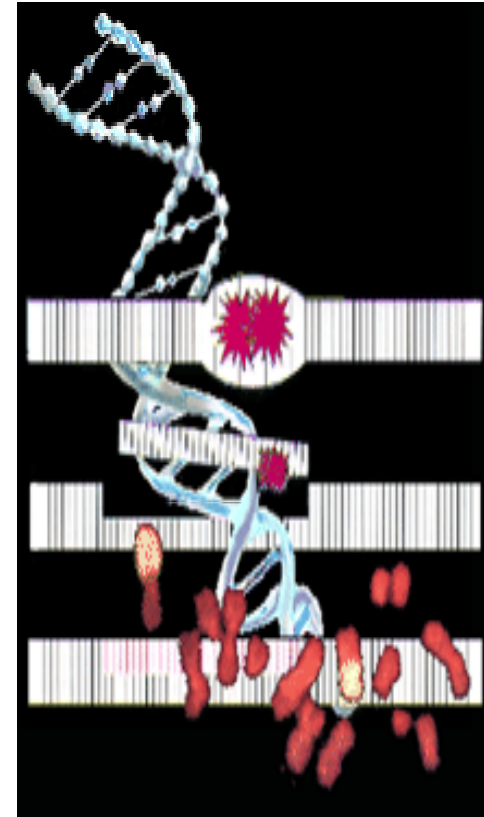

# Nuklearna elektrana i okoliš

# Interakcija NE i okoliša

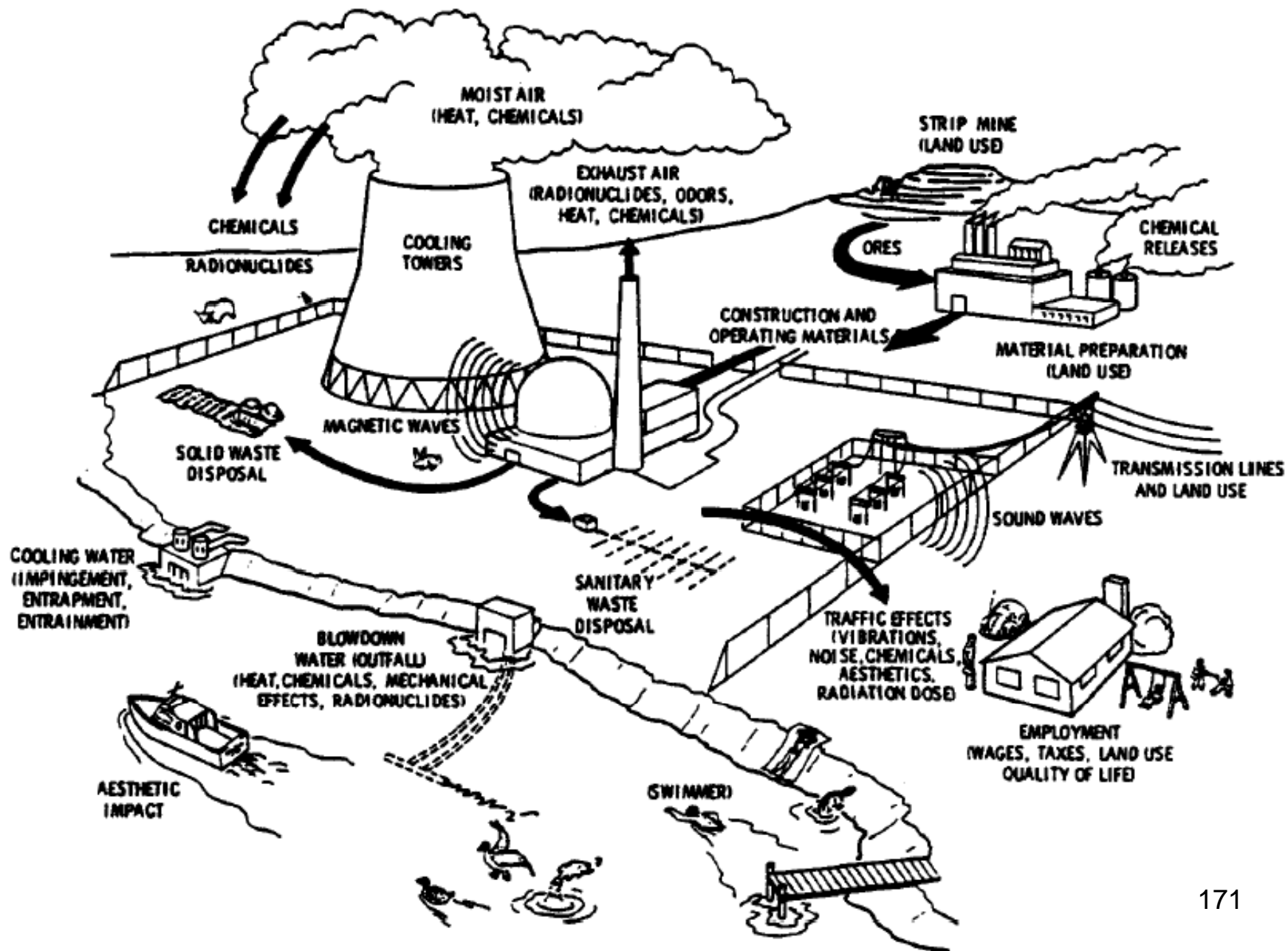

# Normalna ispuštanja

- Vrlo ograničena za vrijeme normalnog pogona
- Pod striktnom administrativnom kontrolom
- Doprinos komparabilan prirodnom nivou zračenja
- Tekuća i plinovita ispuštanja
- Rezultat su curenja goriva i neutronske aktivacije
- “Čekaj i razrijedi” pristup
- ALARA princip

# Sustav za tretiranje nisko i srednjeaktivnog otpada

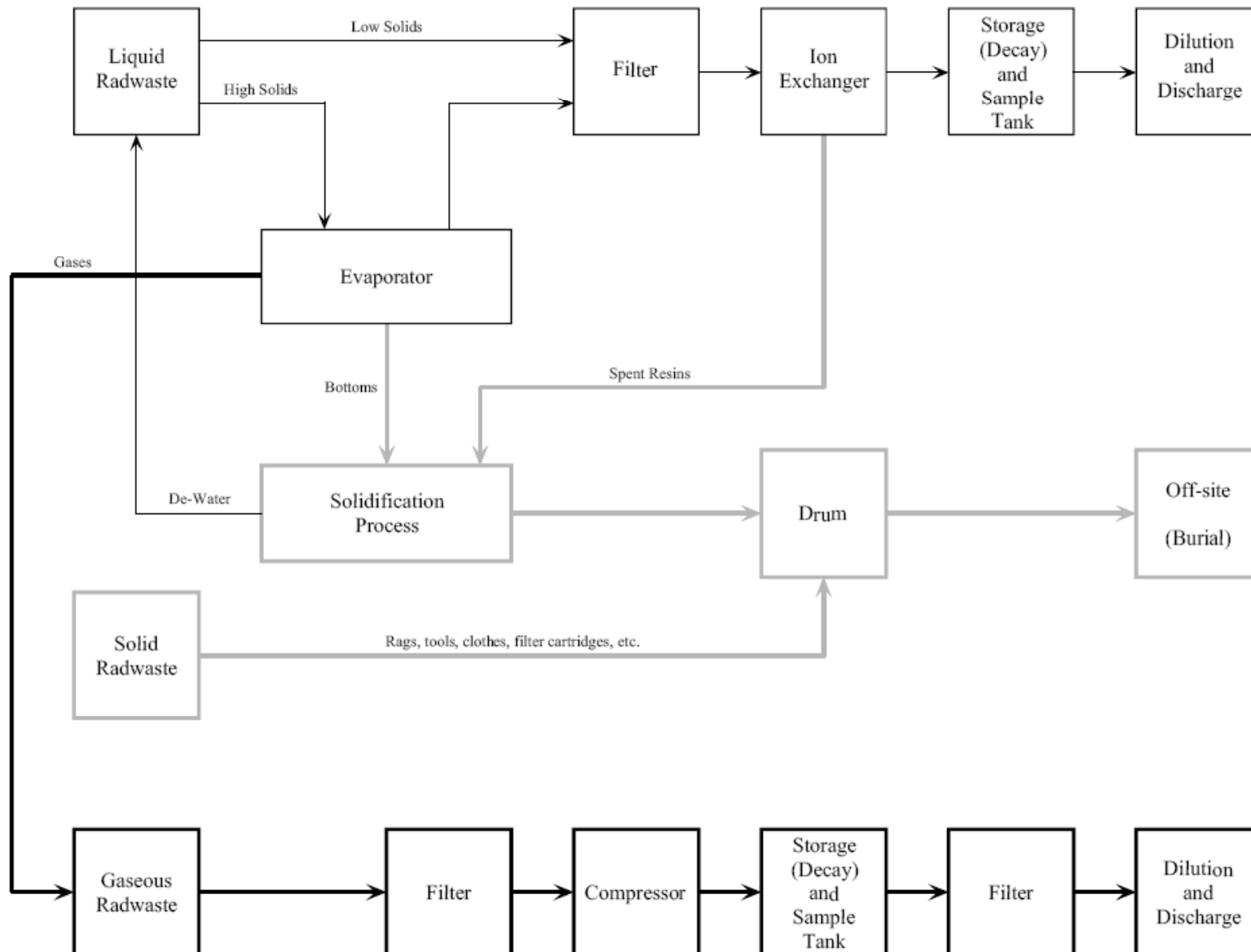

# Doze i okoliš

	Tipične	Interval
	$\mu\text{Sv}/\text{god}$	$\mu\text{Sv}/\text{god}$
<b>Prirodnog porijekla:</b>		
Tlo + kuća: radon	200	200-100,000
Tlo + kuća: gamma	600	100-1000
Kozmičko (nivo mora)	300	
+20 za svakih 100m elevacije	.....	0-500
Hrana, piće & tkivo	400	100-1000
Ukupno	<b>1500</b> (plus dio ovisan o elevaciji)	

### **Ljudsko djelovanje:**

Nuklearni pokusi	3	
Medicina (X-zrake, CT, ... prosjek)	370	do 75,000
Od nuklearne energetike	0.3	
Izgaranje ugljena	0.1	
Kućanski aparati	0.4	
<b>Ukupno</b>	<b>375</b>	

### **Vezano za aktivnosti:**

Skijanje	8 po tjednu	
Putovanje avionom	1.5 - 5 po satu	do 5000/god 175

# Propisani limiti

- *ICRP (International Commission for Radiological Protection) preporučava dodatno na pozadinsko zračenje slijedeće limite:*
  - \* *za stanovništvo 1 mSv/god*
  - \* *za profesionalce 20 mSv/god (usrednjeno unutar 5 godina)*
- *Stvarna ispuštanja u okolici NE su obično u području 0.001 do 0.01 mSv/god*



## Plinovita ispuštanja (inventar jezgre)

Nuklid	Vrijeme poluraspada	Aktivnost (Ci/god)		
		30 min	1 dan	60 dan
Kr*-83	1.86 sat	90,000	12	0
Kr-85	10.8 god	250	250	250
Kr*-85	4.4 sat	160,000	3900	0
Kr-87	2.8 sat	510,000	1500	0
Xe*-131	11.9 dan	420	150	10
Xe-133	5.3 dan	160,000	22,000	50
Xe*-133	2.3 dan	6000	50	0
Xe-135	9.2 sat	540,000	0	0
Xe-138	14 min	780,000	0	0

# I-131 i aerosoli

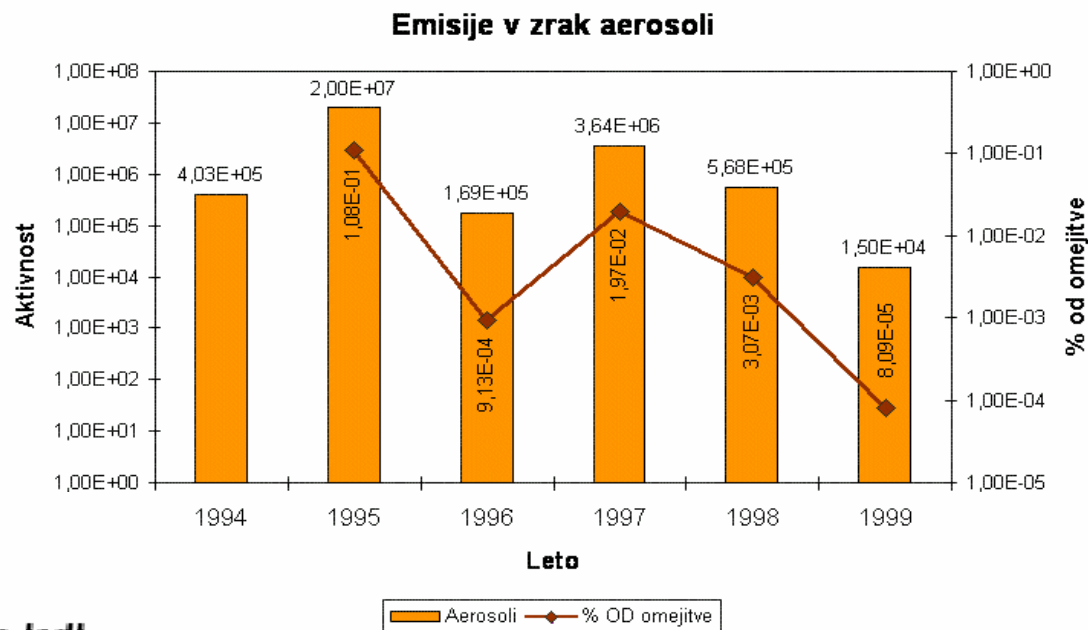

### Emisije v zrak Jodl (I-131 ekvivalent)

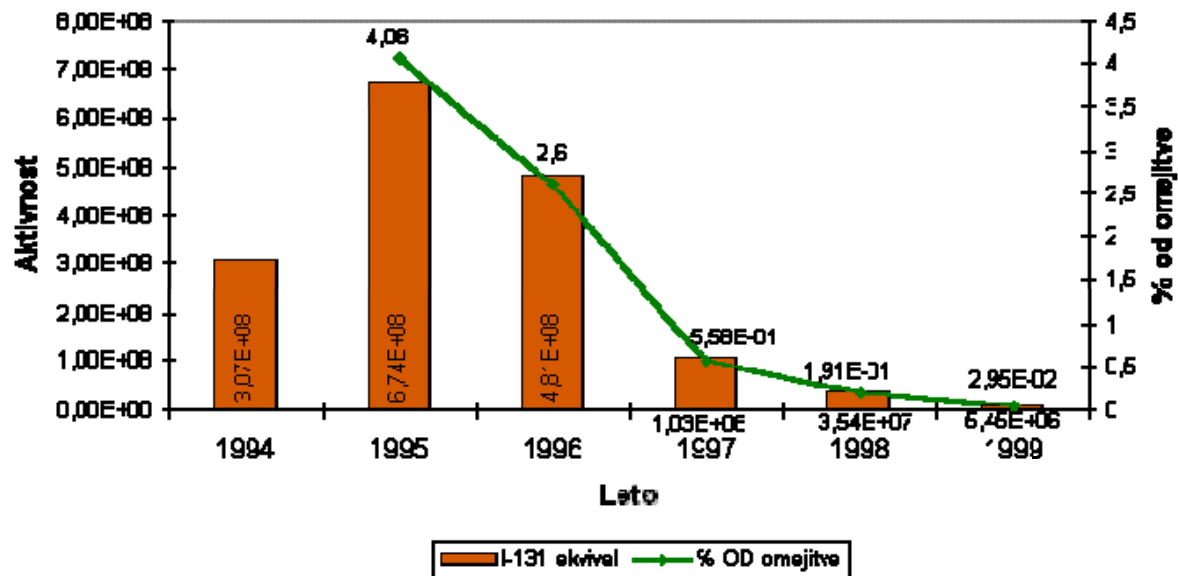

# Okoliš i NE

- James Lovelock (“Gaia”), British chemist - 1997 Blue Planet Prize: "We are headed toward a warmer Earth where most life on the planet will have to move to the Arctic basin, to a few islands, ... My justification for nuclear power is that even the results of an all-out nuclear war pale into insignificance compared to what is going to happen."
- Patrick Moore, a founding member of Greenpeace: "In the 1970s, I equated nuclear energy to holocaust. Now, my views have changed. Nuclear energy may be the energy source that can save our planet from another possible disaster - catastrophic climate change. ... Wind and solar can't replace coal, nuclear, and hydro. Natural gas is too expensive. Nuclear is, by elimination, the only viable substitute for coal. It is that simple."



# Fuzija

# Fuzija

- **Potencijalne prednosti**
  - **Gotovo neograničene količine goriva**
    - ❖ **Deuterij u vodi**
    - ❖ **Tricij iz litija (dio procesa)**
  - **Inherentno sigurni**
  - **Mala količina dugoživućeg radioaktivnog otpada (aktivacija), problem je tricij**
  - **Nema mogućnosti proliferacije**
- **Međunarodna suradnja – ITER, cilj postići 500 MW tijekom 500 do 2500 s**
- **Komercijalizacija tek poslije 2050**
- **Ne očekuje se značajniji doprinos prije druge polovine stoljeća**
- **Moguća razna iznenađenja, male zemlje ?**

# JET (Joint European Torus)

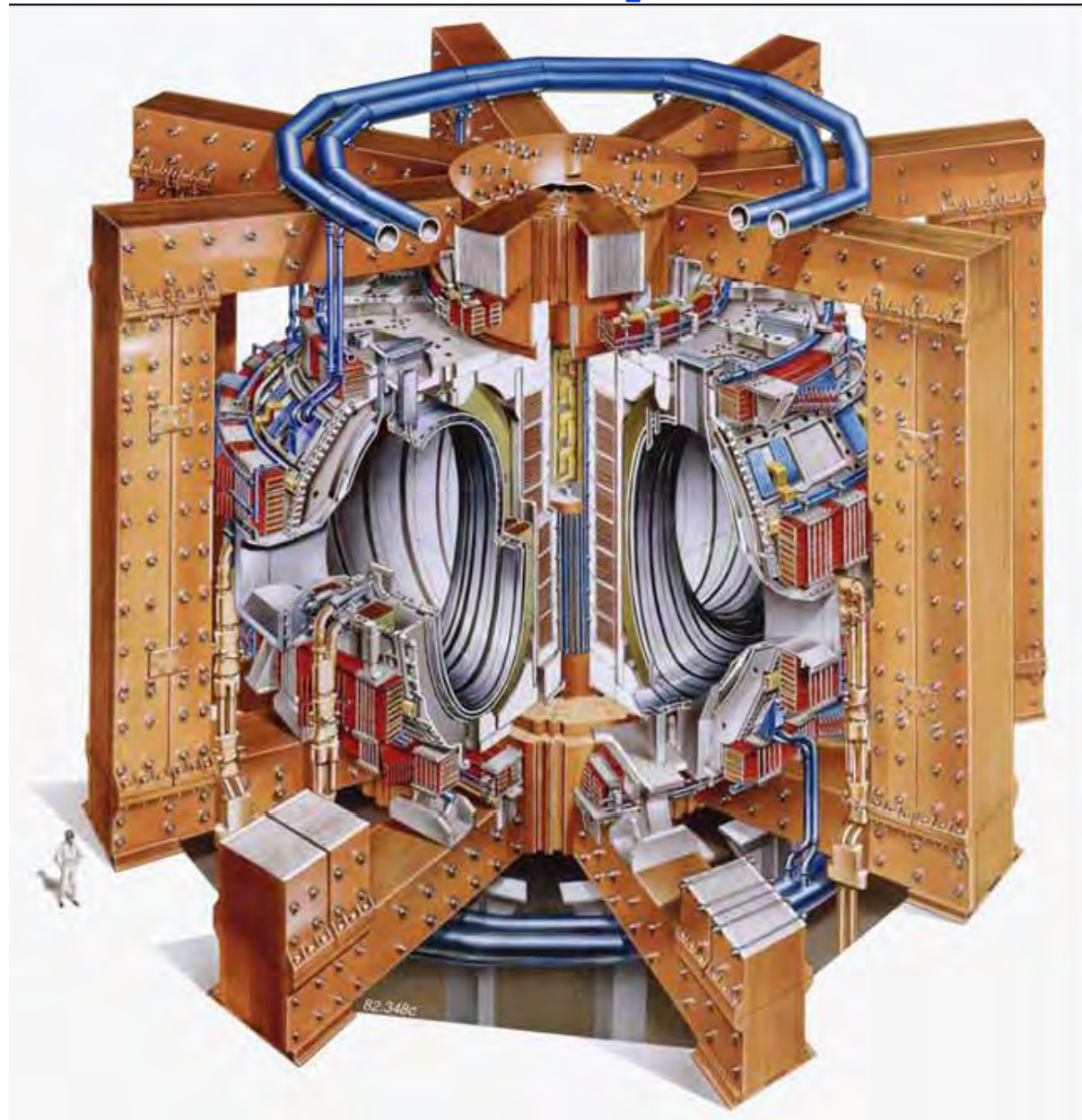



# ITER (International Thermonuclear Experimental Reactor)

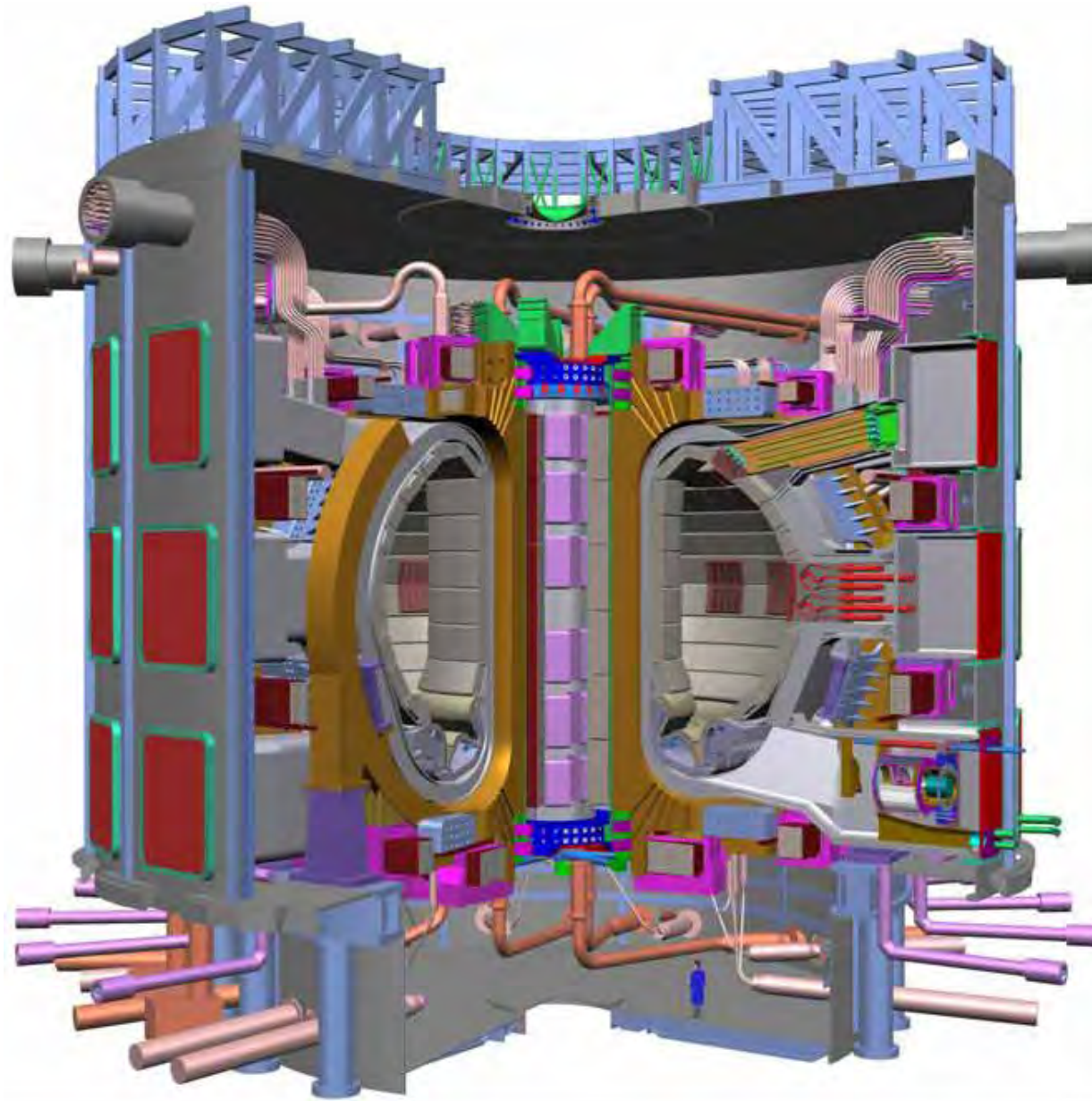

Fusion power	500 MW
Heat flux at 1 <sup>st</sup> wall	0.57 MW/m <sup>2</sup>
Confinement time	≥ 300 s
Plasma radius (torus)	6.2 m
Plasma radius (cross)	2.0 m
Plasma current (ind)	15 MA
Toroidal field at 6.2 m	5.3 T
Plasma volume	837 m <sup>3</sup>
Plasma area	678 m <sup>2</sup>



# Fuzijska elektrana?

